

# 1996-2000 Honda Civic Body Repair Manual

## INTRODUCTION

### How to Use This Manual

This manual covers the repairs of a 1996-2000 Honda Civic that has been involved in an accident, and it describes the work related to the replacement of damaged body parts. Please read through these instructions and familiarize yourself with them before actually using this manual.

NOTE: Refer to the appropriate 1996-2000 Civic Service Manual for specifications, wire harness locations, safety stand support points, etc.

### Special Information

#### **⚠ WARNING**

Indicates a strong possibility of severe personal injury or death if instructions are not followed.

#### **⚠ CAUTION**

Indicates a possibility of personal injury or equipment damage if instructions are not followed.

NOTE: Gives helpful information.

#### **⚠ CAUTION**

Detailed descriptions of standard workshop procedures, safety principles and service operations are not included. Please note that this manual does contain warnings and cautions against some specific service methods which could cause PERSONAL INJURY, damage a vehicle, or make it unsafe. Please understand that these warnings cannot cover all conceivable ways in which service, whether or not recommended by Honda, might be done or of the possible hazardous consequences of each conceivable way, nor could Honda investigate all such ways. Anyone using service procedures or tools, whether or not recommended by Honda, must satisfy himself thoroughly that neither personal safety or vehicle safety will be jeopardized.

All information contained in this manual is based on the latest product information available at the time of printing. We reserve the right to make changes at any time without notice. No part of this publication may be reproduced, stored in retrieval system, or transmitted, in any form by any means, electronic, mechanical, photocopying, recording, or otherwise, without the prior written permission of the publisher. This includes text, figures and tables.

## Body Repair

**1** Preparation of Work

**2** Welding Methods/Repair Tools

**3** General Information

**4** Replacement

**5** Cross Section of Body and Sealants

**6** Body Dimensional Drawings

**7** Rust-preventive Treatments

## Paint Repair

**8** Body Paint Repair

**9** Resin Parts Paint Repair (Exterior)

Service Precautions

General Safety Precautions

# Preparation of Work

- Description ..... 1-2
- Checkpoints ..... 1-4
- Correction of the Damaged Area ..... 1-5
- Measurement (Excluding small damage) ..... 1-7
- Positioning Jigs ..... 1-8

# Preparation of Work

## Description

- Most monocoque bodies are composed as a single unit by welding together pressed parts made of steel plates which come in a variety of different shapes and sizes. Each part is responsible for displaying a certain strength and durability in order that it may play its role in meeting the functions of the body as a whole.

Damage to the exterior of the body can be inspected visually, but where there has been an external impact, it is necessary to inspect the extent of the damage. In some cases, the deformation has spread beyond the actual areas which were in the collision and so this has to be inspected closely.

Unit: mm (in)

### 4-Door:

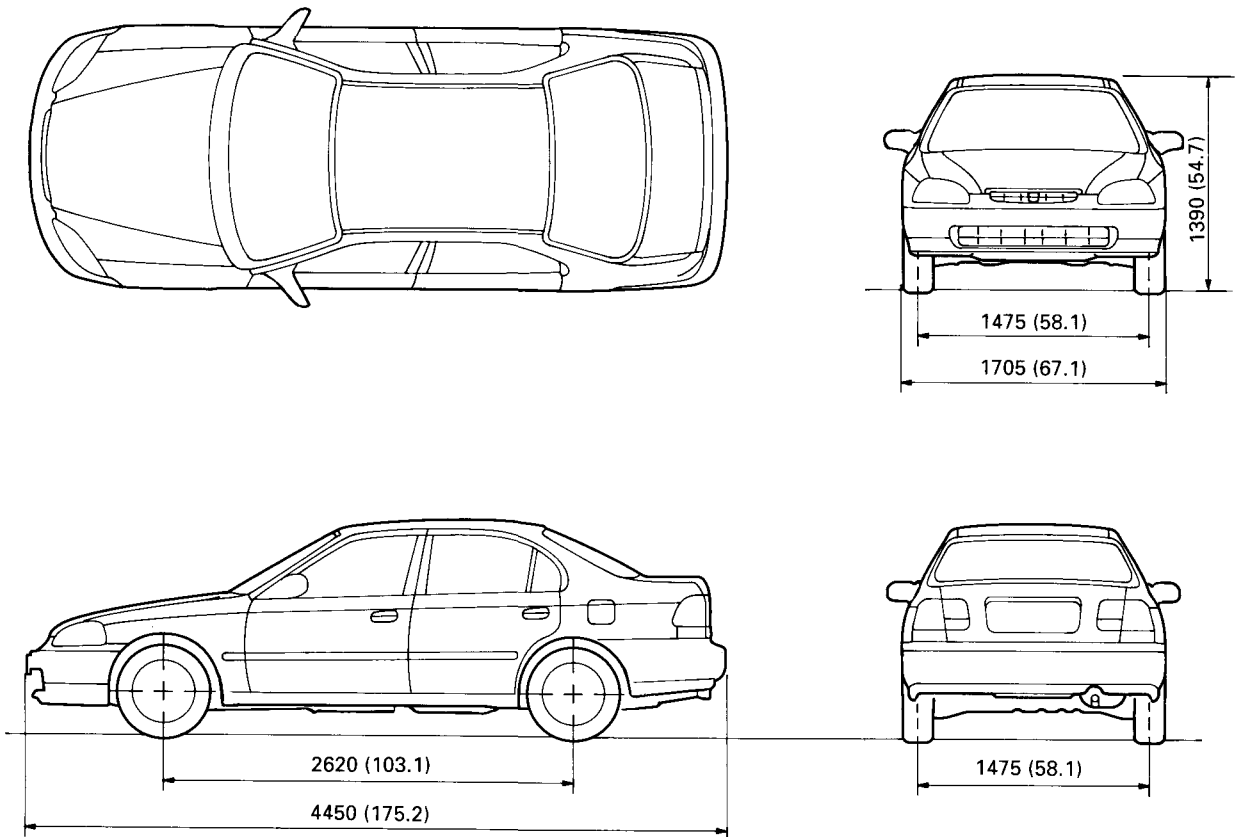

#### Front wheel alignment:

Camber	$0^{\circ}00' \pm 1^{\circ}$	
Caster	$1^{\circ}40' \pm 1^{\circ}$	
Total toe	IN $1 \pm 2$ (0.04 $\pm$ 0.08)	
Wheel turning angle	in	$39^{\circ}50'$
	out	$33^{\circ}10'$

#### Rear wheel alignment:

Camber	$-1^{\circ} \pm 1^{\circ}$
Total toe	IN $2 \pm 2$ (0.08 $\pm$ 0.08)

3-Door:

Unit: mm (in)

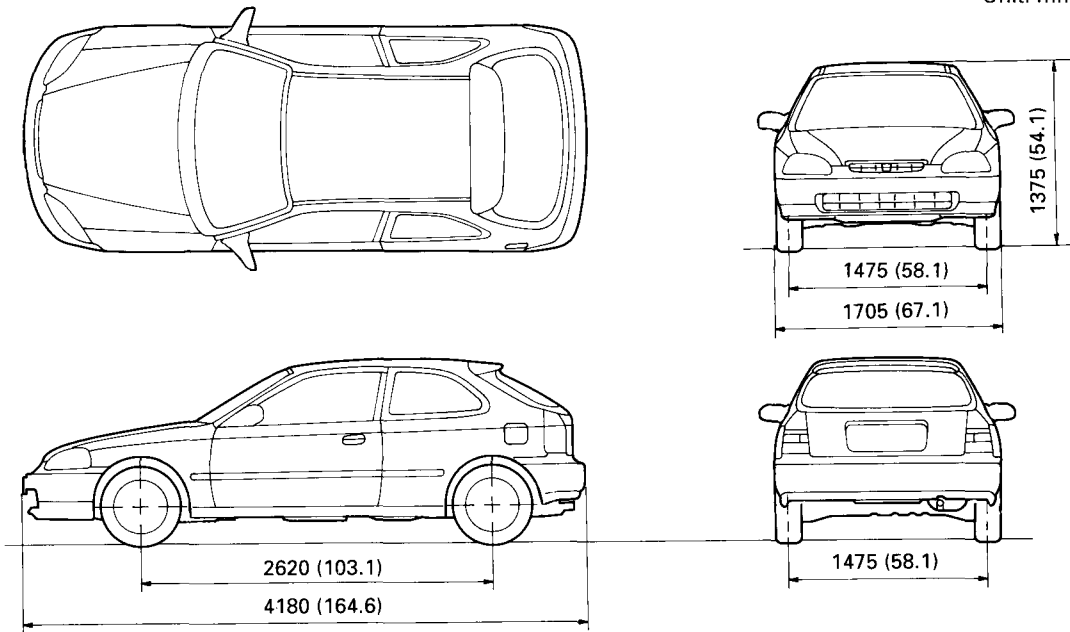

2-Door:

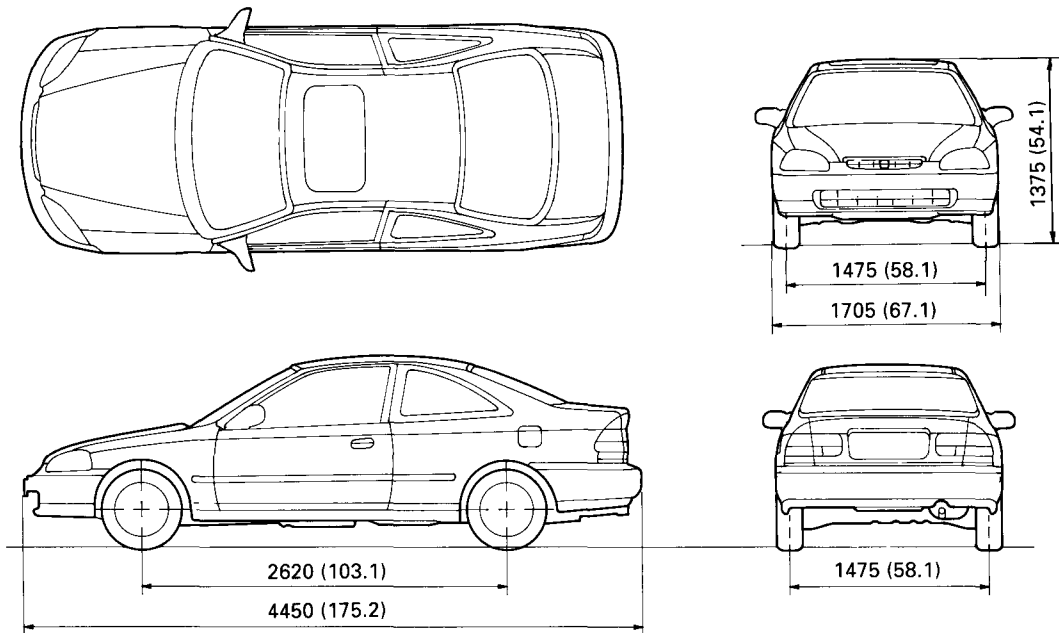

**Front wheel alignment:**

Camber	0°00' ± 1°	
Caster	1°40' ± 1°	
Total toe	IN 1 ± 2 (0.04 ± 0.08)	
Wheel turning angle	in	39°50'
	out	33°10'

**Rear wheel alignment:**

Camber	-1° ± 1°
Total toe	IN 2 ± 2 (0.08 ± 0.04)

# Preparation of Work

## Checkpoints

- **Accurate Inspection of Damaged Parts (Visual)**

### Seat Belts

#### Replace the seat belts if:

1. The belt material is cut, punctured, burned or in any way damaged.
2. The buckle or retractor does not work properly.
3. They were being worn at the time of a collision (check for damage at the seat belt anchor points).
4. Their condition is questionable.

### Front Section:

1. Is there any bending, splitting, denting or other damage to the suspension and its related parts?
2. Is there any deformation of the front bulkhead or radiator core? Have any of the connected sections come apart?
3. Are there any creases or distortion in the front wheelhouse or side frame? Have any of the connected sections come apart?
4. Is there any bending or twisting of the whole front area?
5. Is there any deformation like creases, bulges, or dents in the front pillar, dashboard, floor, etc.?
6. Is there any vertical twisting or misaligned clearance in the door?
7. Is the windshield seal broken?
8. Is there any deformation in the vicinity of the top part of the roof panel's center pillar?
9. Is there any damage inside the automobile (is there any twisting of the dashboard, or anything irregular with the clearances or sheet-mounting parts)?
10. Is there any damage to the steering wheel? Is there any deformation in the column and the column-mounted parts?
11. Is there any oil or water leakage and damage to the engine, transmission or brakes?
12. Is there any irregular noise in the gear changing operation, engine and transmission rotation?
13. Are there any traces of contact between the engine block and the dashboard lower panel?
14. Is there any damage to brake or fuel lines, or wire harnesses?

### Rear Section:

1. Is there any twisting, bulging or denting of the rear floor and rear bolsters? Have any of the connected sections come apart?
2. Is there any irregular bulging or denting in the rear fender?
3. Is there any distortion in the rear inner panel? Is there any bending and denting in the vicinity of the rear pillar?
4. Is there any distortion or creasing in the rear wheelhouse and arch sections? Have any of the connected sections come apart?
5. Is there any twisting or misalignment of the clearance of the trunk lid or hatch opening section?
6. Is there any bending, splitting, denting or other damage to the suspension and its related parts?
7. Is there any deformation of the rear floor, rear floor cross member and damper base? Have any of the connected sections come apart?

## Correction of the Damaged Area

Set the frame corrector on the car body.  
 The side sill is flangeless to allow reshaping by pulling it out.  
 Use the horizontal pinch welds for anchoring the car.

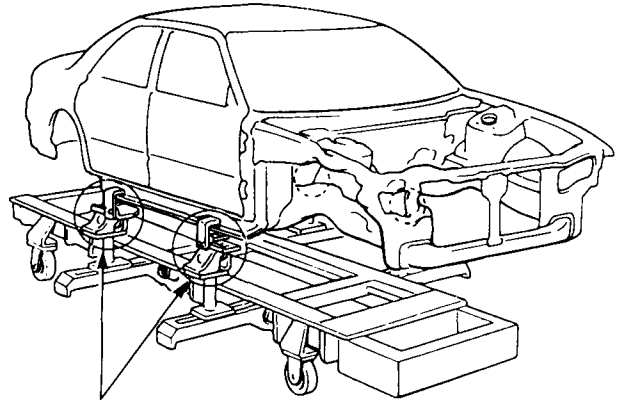

**UNDERBODY CLAMPS**

### Underbody Clamp Specifications:

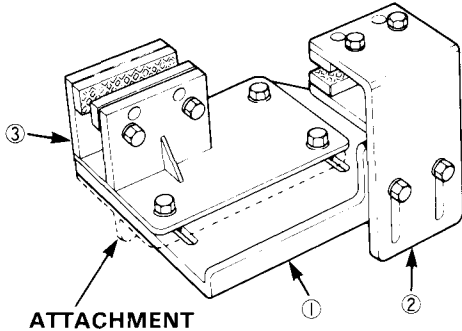
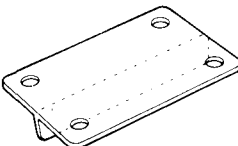
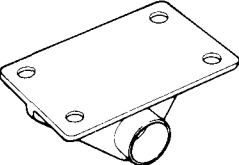
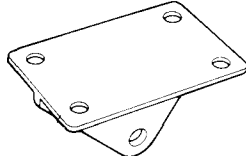
UNDERBODY CLAMP (Special tool)	Clamp Number	
 <p><b>ATTACHMENT</b></p>	<p>AT-63</p> <p>① Clamp body                  ② Side clamp                  ③ Under clamp</p>	<p>Underbody Clamp:                  AMERICA KOWASEIKI, INC.                  20013 South Rancho Way                  Rancho Dominguez,                  California 90220                  TEL 310-638-1000                  FAX 310-638-3005</p>
<p>Standard type:</p> 	<p>AT-63-AL</p>	<p>Frame correctors</p> <ul style="list-style-type: none"> <li>● Dataliner</li> <li>● Celette</li> <li>● Car-o-liner</li> <li>● Flex-o-liner</li> <li>● etc.</li> </ul>
<p>C - type:</p> 	<p>AT-63-C</p> <p>Inner diameter                  65 mm (2.6 in)</p>	<ul style="list-style-type: none"> <li>● Korek</li> <li>● Auto pole</li> <li>● etc.</li> </ul>
<p>U - type:</p> 	<p>AT-63-U</p> <p>Inner diameter                  20 mm (0.8 in)</p>	<ul style="list-style-type: none"> <li>● U-Base</li> <li>● Pro-Tec</li> <li>● etc.</li> </ul>

(cont'd)

# Preparation of Work

## Correction of the Damaged Area (cont'd)

1. Apply load to the damaged section, and pull it out until the section is almost restored to the original shape.
2. Check that the parts of the body that are covered have been more or less restored to their original shapes.  
NOTE: Check the original position using the body dimensional drawings (see [section 6](#)) and the positioning jigs (see page [1-8](#)).
3. Remove the parts that require replacement.
4. Decide whether to replace all the affected parts or whether to cut the weld joint parts and replace them.
5. Cut off and separate the damaged parts.  
NOTE: When cutting the parts off, take special care that you do not damage adjacent parts on the vehicle.

### Setting Condition of Replacement Parts Joint Sections:

- Make sure that you can perform straightening work after welding.
- Make sure that the locations are not susceptible to distortion caused by other parts.
- Make sure that there are few removable parts and that the location allows safe welding.
- Make sure that the joints are short, and that paint repair can be performed easily.
- Make sure the locations are such that the joints can be finished in a way that does not affect the outward appearance.
- Make sure that the locations do not hinder the removing and attaching of parts.  
NOTE: Bear in mind all of these conditions, and after determining the joint locations, cut the joints for an overlap of 20–30 mm (0.8–1.2 in).

6. Mold the related parts.
7. Set and tack weld the replacement parts.  
NOTE: Temporarily mount the related parts, and check the clearance and level differences.

8. Weld the replacement parts.  
(For welding methods, see [section 2](#).)

**CAUTION: Protect body parts with the heat-resistant protective cover to prevent damage, when welding.**

NOTE: Use of the positioning jig is recommended.

9. Apply anti-rust agent.

The paint film, which is designed to prevent corrosion caused by moisture, is destroyed around the edges of the locations which have been repaired by welding.

Therefore, in such places and especially in those areas which are not visible, apply another coat of the paint, referring to the anti-corrosion painting manual. This operation is designed to maintain durability and quality (see [section 7](#)).

## Measurement (Excluding small damage)

Whenever possible, make judgements and conclusions based on measurement. Measure the wheel alignment (see pages 1-2, 1-3) so as to prevent any future trouble like unsymmetrical wear of the tires or catching of the steering wheel.

If there are any deviations, use a tram tracking gauge and measure parts of the body.

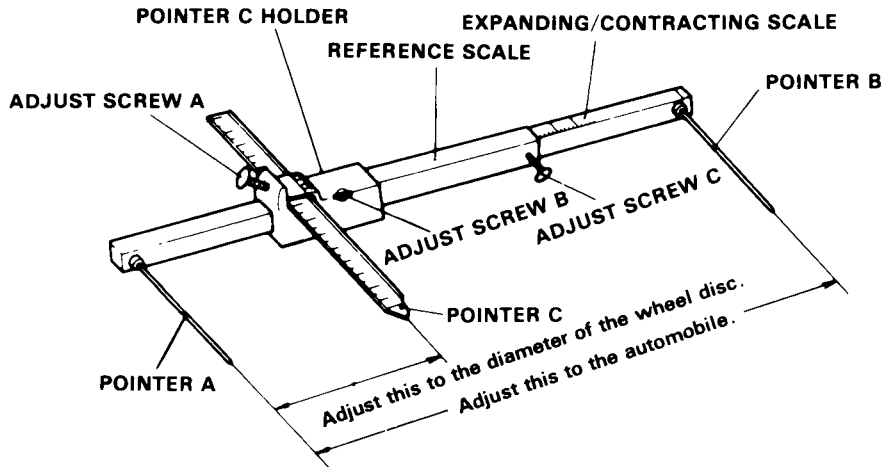

If there is any twisting to the body, measure using a frame centering gauge.

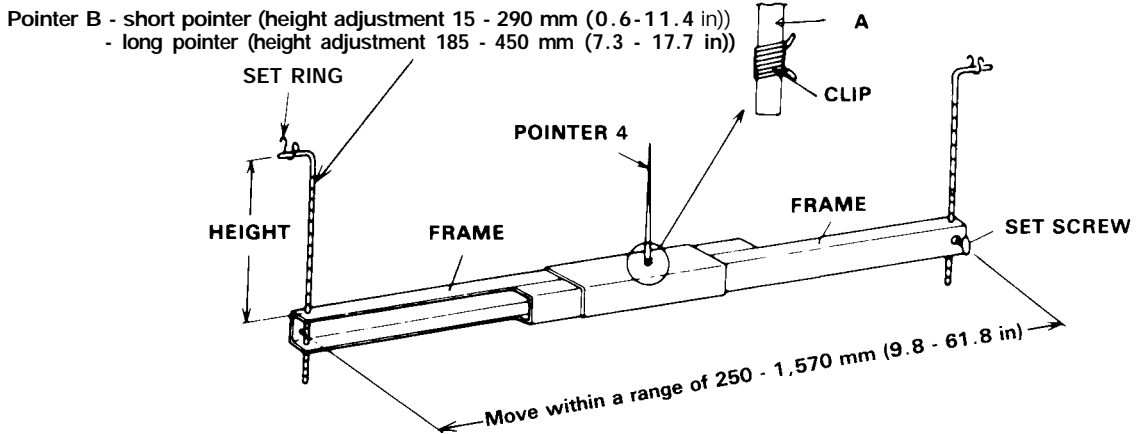

When measuring body dimensions, use a universal tram gauge.

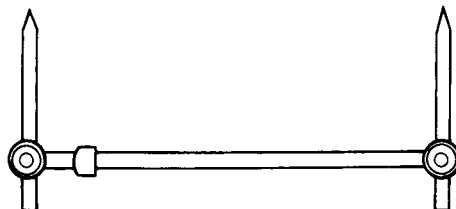



# Preparation of Work

## Positioning Jigs

No.	Jig Number	Description	Page Reference
①	HJ-35	Under frame positioning jig set	
①-1	HJF-01	Frame	4-9, 4-13, 4-18, 4-54, 4-57
①-2	HJ-20F	Front jig brackets	4-9, 4-13, 4-18
①-3	HJ-35R	Rear jig brackets	4-54, 4-57

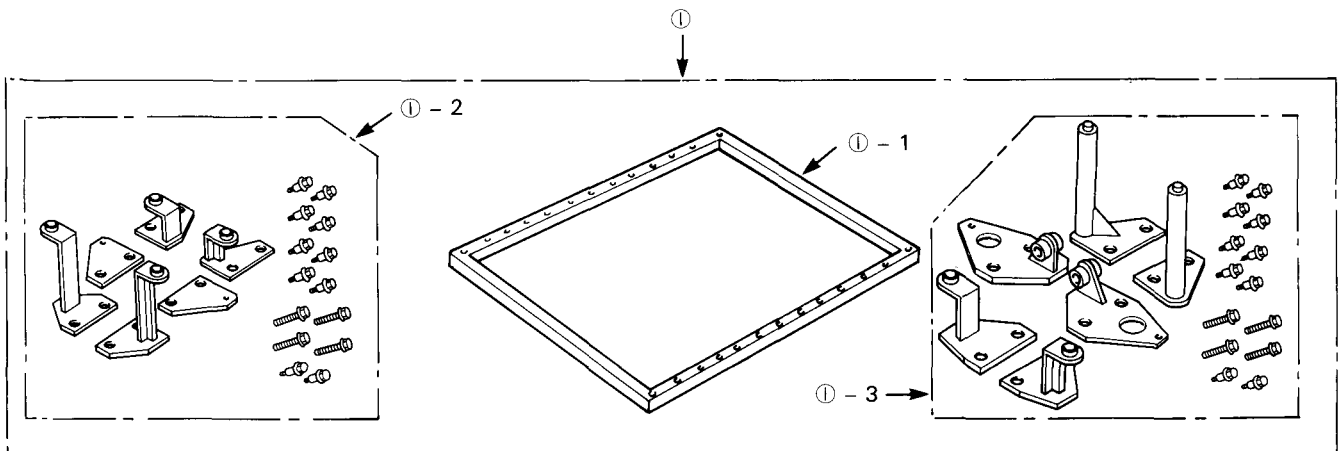
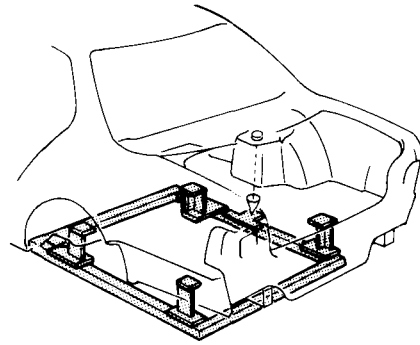
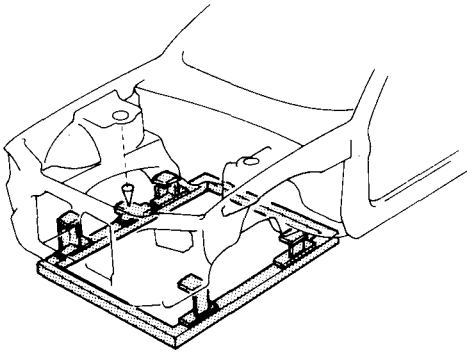

Positioning Jig: AMERICA KOWA SEIKI, INC.

20013 South Rancho Way, Rancho Dominguez, California 90220

TEL 310-638-1000

FAX 310-638-3005

## **Welding Methods / Repair Tools**

<b>Spot Welding .....</b>	<b>2-2</b>
<b>Gas Welding .....</b>	<b>2-4</b>
<b>Carbon Dioxide Arc Welder (MIG Arc Weld) .....</b>	<b>2-5</b>
<b>Examples of Repair Tools .....</b>	<b>2-6</b>

# Welding Methods/Repair Tools

## Spot Welding

Spot welding is also known as resistance spot welding, and it is the most suitable method of welding for automobiles. It has three main features: the welding can be performed instantaneously, it exercises very little effect on the mother material, and it reduces the generation of distortion to the absolute minimum. However, please remember to remove all paint and other impurities from the surface of the material you intend to weld for reliable results.

### Welders:

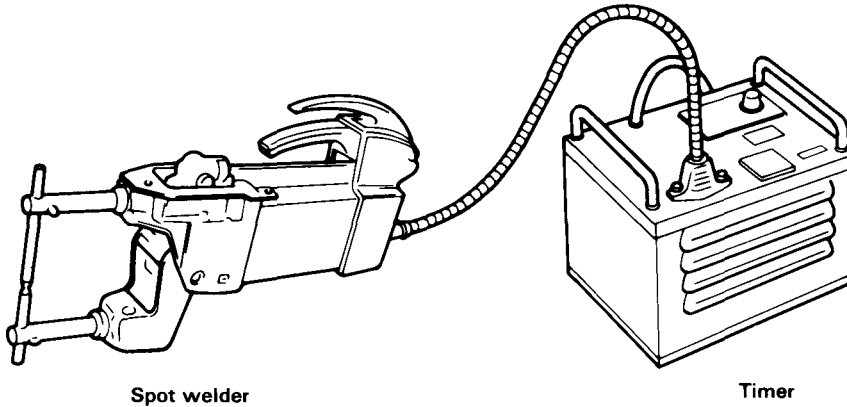

Spot welder

Timer

### Welding Conditions:

When performing spot welding, make absolutely sure that you conform to the conditions governed by the current, conductivity time, welding pressure, holding time, and shutdown time recommended for the spot welder.

Please bear in mind the following points when welding:

- Plate thickness and minimum welding pitch

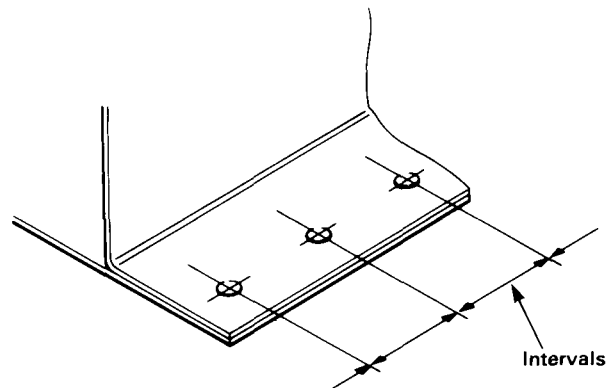
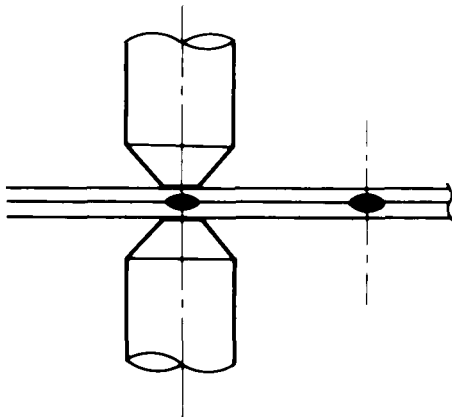

NOTE: When the welding intervals are too small, this leads to branching, making it impossible to maintain the desired soldering state.

- Plate thickness and tip diameter

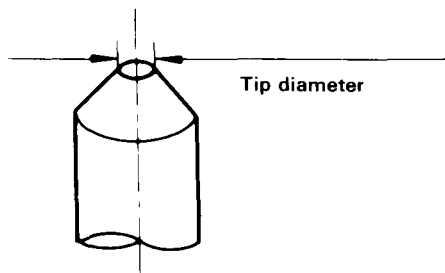

Unit: mm (in)

Plate thickness	0.6 (0.02)	0.9 (0.04)	1.2 (0.05)	1.6 (0.06)
Minimum intervals	11 (0.43)	16 (0.63)	20 (0.79)	24 (0.94)

Unit: mm (in)

Plate thickness	0.8 (0.03)	0.9 (0.04)	1.2 (0.05)	1.6 (0.06)
Tip diameter	4.5 (0.12)	5.0 (0.2)	5.5 (0.22)	6.0 (0.24)

• **Welding Strength Test**

Even if you perform the welding in accordance with the conditions, the strength of the welded sections may fluctuate widely with drops in the voltage and other factors. The quality of the welding cannot be evaluated unless the welded sections are destroyed. Provide yourself with a steel plate of the same thickness and conduct a destruction test.

- If holes appear in the steel plates, this means that the welding is standard strength.

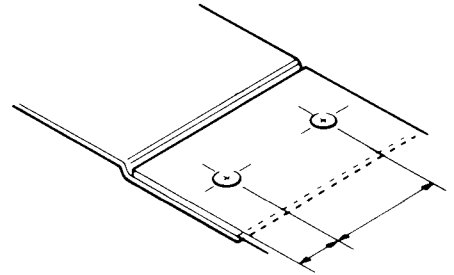
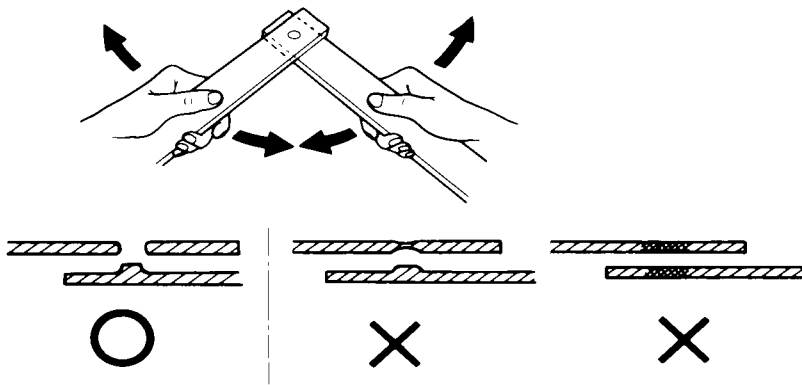

- Drive a wedge between two panels near the nugget. If the welded parts do not come apart and the diameter of the nugget is more than 3mm (0.1 in), the welding should be satisfactory.

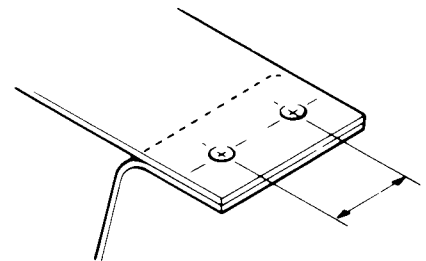
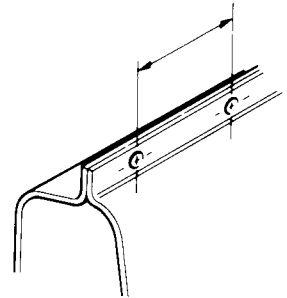
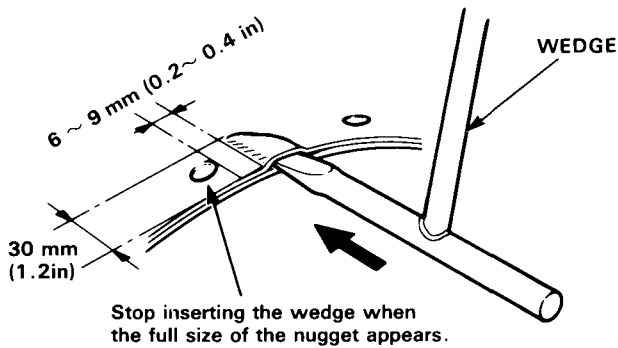

NOTE:

It is difficult to perform spot welding in the following circumstances:

- When it is not possible to remove any rust or paint attached to the welding surfaces.
- When the tip of the spot welder cannot be inserted into the welding section.
- When the welding surfaces can be seen from the outside and welding will impair the exterior appearance.

In all these cases, the gas welding method should be employed. Moreover, if it is not possible to perform spot welding because of space restrictions, plug welding using on the arc welding method may be performed instead. For plug welding, the sections to be welded must be close together.

# Welding Methods/Repair Tools

## Gas Welding

Gas welding is indispensable for body repair because of the broad range of its applications for joining the body panels, cutting the materials that construct the body, and applying heat to reform panels, and also because it is easy to get hold of the tools. However, this method requires experience.

### Welders:

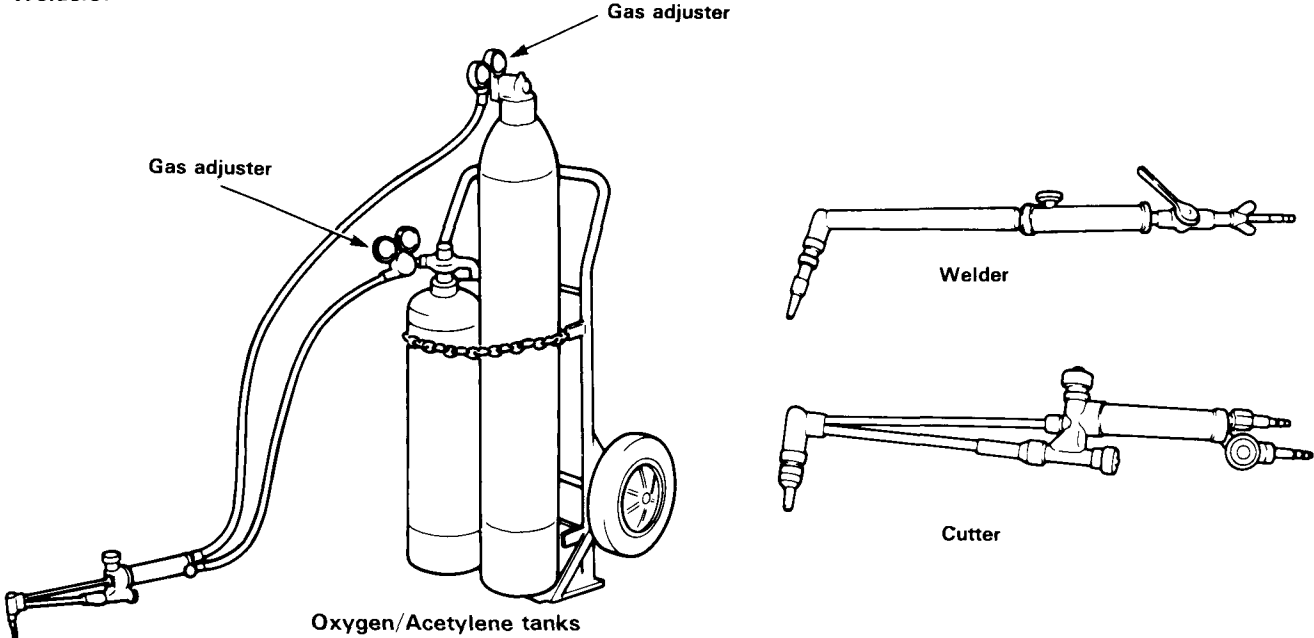

### Welding Methods:

#### Butt welding

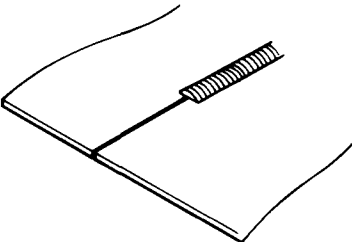

#### Fillet welding or soldering

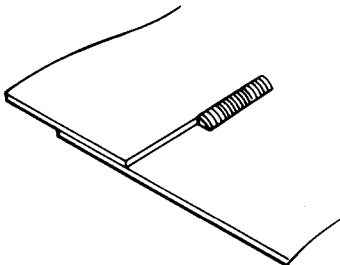

## Carbon Dioxide Arc Welder (MIG Arc Weld)

This welding process uses inexpensive carbon dioxide instead of expensive inert gases as a shielding means. Consumable metal electrodes are employed. It has a wide range of applications, including butt welding of thin plate, fillet welding, plug welding, and MIG spot welding. In terms of the weld strength, it is also highly stable.

### Welders:

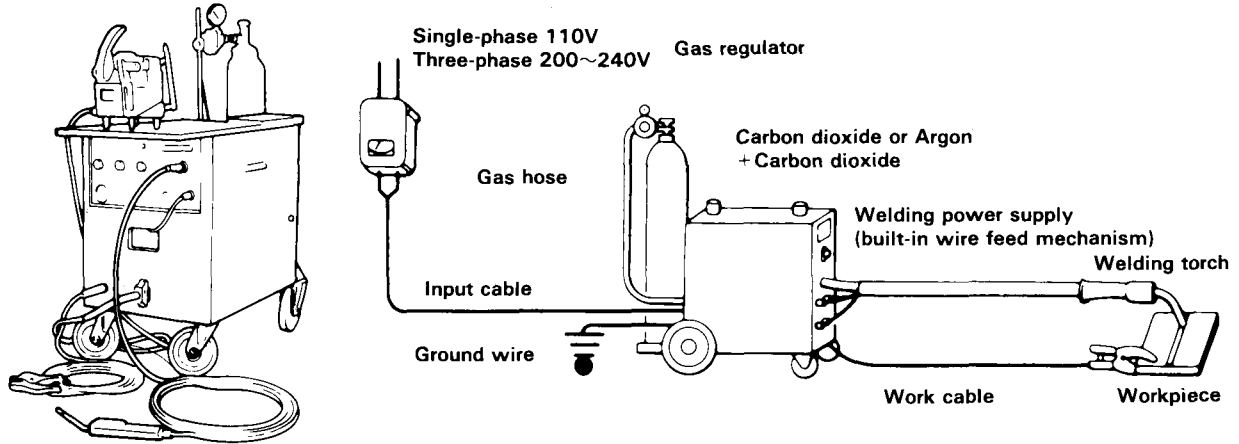

**CAUTION:** Disconnect the negative battery cable before arc welding.



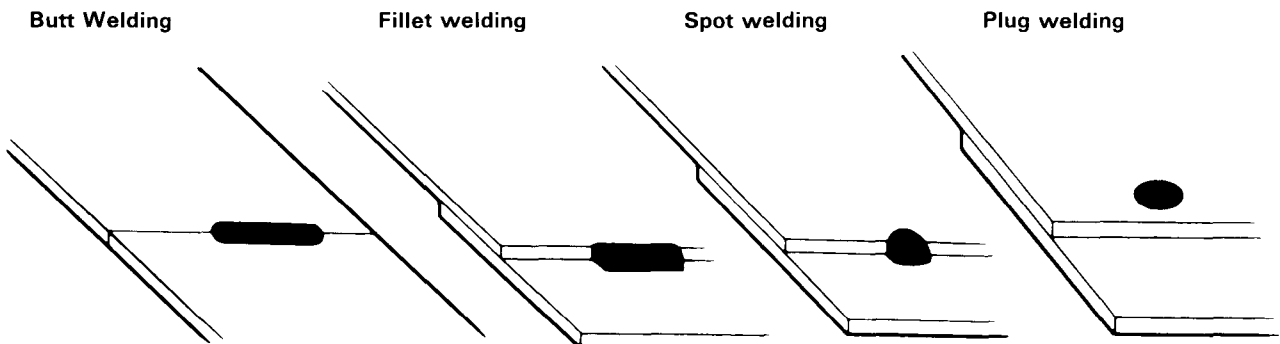

### Welding Methods:

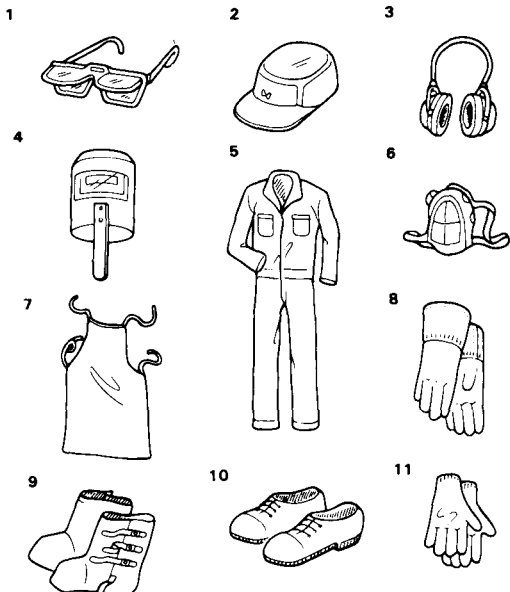
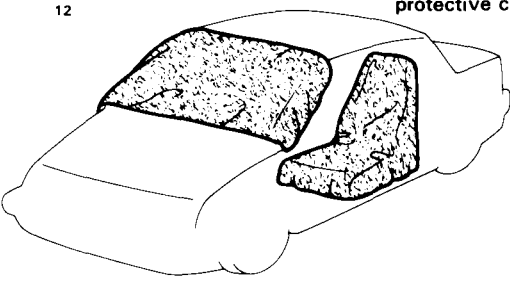
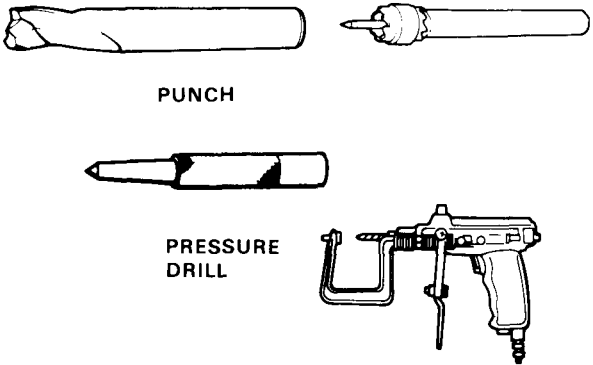

# Welding Methods/Repair Tools

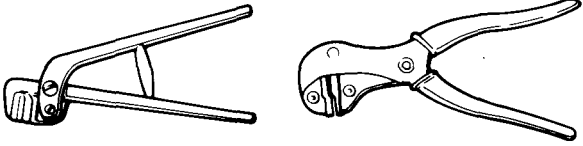
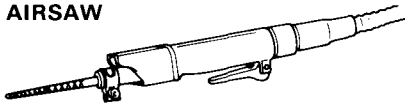
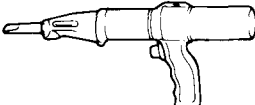
## Examples of Repair Tools

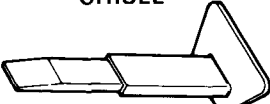
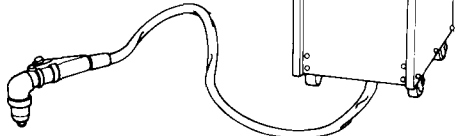
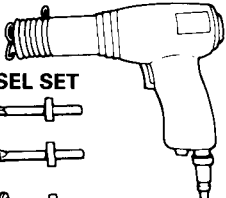
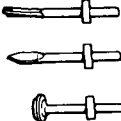
Item	Work	Tools, equipment used
Protective tools	Operator	<ol style="list-style-type: none"> <li>1. Protective goggles</li> <li>2. Cap</li> <li>3. Ear plug</li> <li>4. Shield for eyes</li> <li>5. Overalls with long sleeves</li> <li>6. Dust-proof mask</li> <li>7. Protective apron</li> <li>8. Welding gloves</li> <li>9. Foot protectors</li> <li>10. Safety shoes</li> <li>11. Work gloves</li> <li>12. Spattering guard</li> </ol> 
	Vehicle body	<p>12 <span style="float: right;">Heat-resistant protective cover.</span></p> 
Processing tools	Plug hole drilling	<p><b>DRILLING BLADE, DRILL, SPOT CUTTER</b></p>  <p><b>PUNCH</b></p> <p><b>PRESSURE DRILL</b></p>

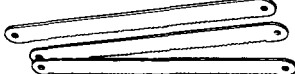
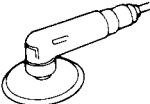
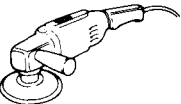
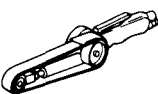
Item	Work	Tools, equipment used
Flange tools	Edge preparation	
Cutting tools	Cutting	<p data-bbox="798 571 899 596"><b>AIRSAW</b></p>  <p data-bbox="798 716 946 741"><b>AIR JIGSAW</b></p>  <p data-bbox="877 903 1006 928"><b>HANSAW</b></p>  <p data-bbox="891 1162 980 1187"><b>CHISEL</b></p>  <p data-bbox="802 1379 1006 1404"><b>PLASMA CUTTER</b></p>  <p data-bbox="1121 685 1369 710"><b>AIR IMPACT CUTTER</b></p>  <p data-bbox="1107 820 1228 845"><b>CHISEL SET</b></p>  <p data-bbox="1124 1017 1302 1042"><b>HAND NIBBLER</b></p>  
Sanding tools	Cleaning	<p data-bbox="783 1597 951 1622"><b>DISC SANDER</b></p> <p data-bbox="802 1670 899 1694">Air type:</p>  <p data-bbox="988 1670 1144 1694">Electric type:</p>  <p data-bbox="1213 1597 1381 1622"><b>BELT SANDER</b></p> 

(cont'd)



# Welding Methods/Repair Tools

## Examples of Repair Tools (cont'd)

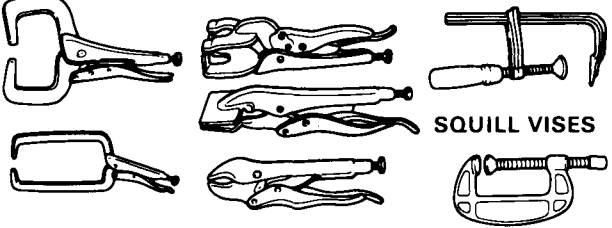
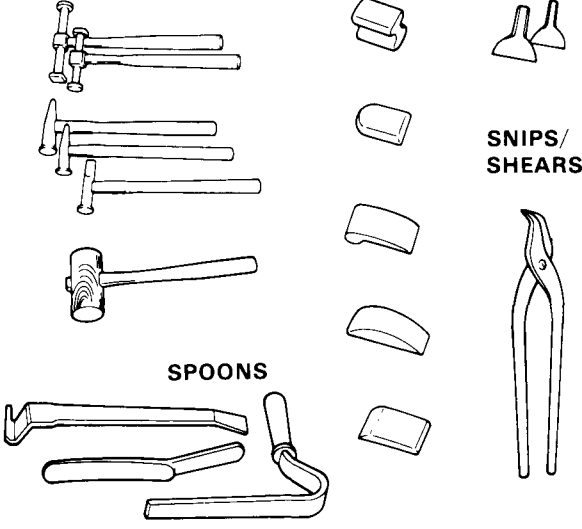
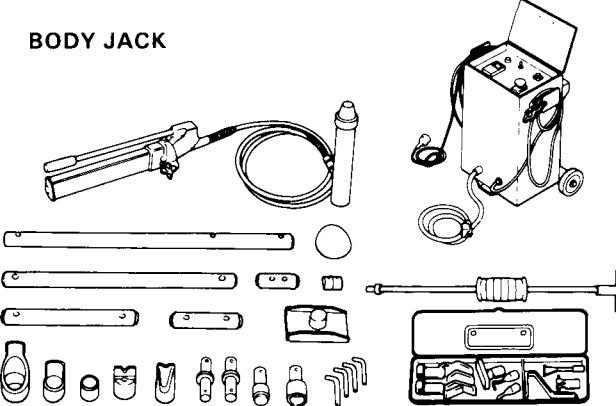
Item	Work	Tools, equipment used
Fixing tools	Base metal fixing	<p data-bbox="777 360 914 385"><b>WISE-GRIPS</b></p> <p data-bbox="1207 360 1386 385"><b>SCREW CLAMP</b></p> <p data-bbox="1207 513 1371 538"><b>SQUILL VISES</b></p> 
Shaping tools	Skin panel shaping	<p data-bbox="798 708 923 733"><b>HAMMERS</b></p> <p data-bbox="1101 708 1199 733"><b>DOLLIES</b></p> <p data-bbox="1264 708 1347 733"><b>CHISEL</b></p> <p data-bbox="1264 886 1362 940"><b>SNIPS/SHEARS</b></p> <p data-bbox="940 1123 1041 1147"><b>SPOONS</b></p> 
	Body, frame shaping	<p data-bbox="804 1392 940 1417"><b>BODY JACK</b></p> <p data-bbox="1222 1330 1326 1355"><b>WELDER</b></p> <p data-bbox="1163 1777 1356 1802"><b>SLIDE HAMMER</b></p> 

# General Information

Zinc-plated Steel Plate Repair ..... 3-2  
Door and Bumper Reinforcement ..... 3-4

# General Information

## Zinc-plated Steel Plate Repair

The zinc-plated steel plate used in some panels of the Civic requires different repair techniques than ordinary steel plate. Plate to "Body Construction" (see pages 4-2, 4-3, 4-4) for the location of the zinc-plated panels.

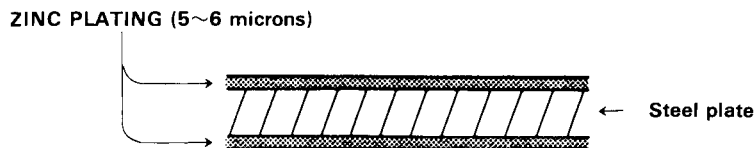

1. Before spot welding the zinc-plated steel plate, remove the paint from both sides of the flange to be welded. Apply sealer to the flange after welding.

**⚠ WARNING** To prevent eye injury, wear goggles or safety glasses whenever sanding, cutting or grinding.

NOTE: Seal the sanded surfaces thoroughly to prevent rust.

2. The electric continuity properties of zinc-plated steel plate is different from ordinary steel plate. When spot welding, increase the current by 10-20%, or increase the resistance welding time. Increase the number of weld spots by 10-20% also.

NOTE: The MIG welding procedures for zinc-plated steel plate are the same as for ordinary steel plate.

**⚠ WARNING** To prevent eye injury and burns when welding, wear an approved welding helmet, gloves and safety shoes.

3. Before applying putty or body filler to the zinc-plated steel plate, sand the zinc plating thoroughly to promote adhesion and prevent blistering.

NOTE:

- Use only epoxy-based putties and fillers on zinc-plated steel plate.
- Follow the manufacturer's specification.

4. When performing paint work, apply caulking to the ground wire mounting position to mask the body.

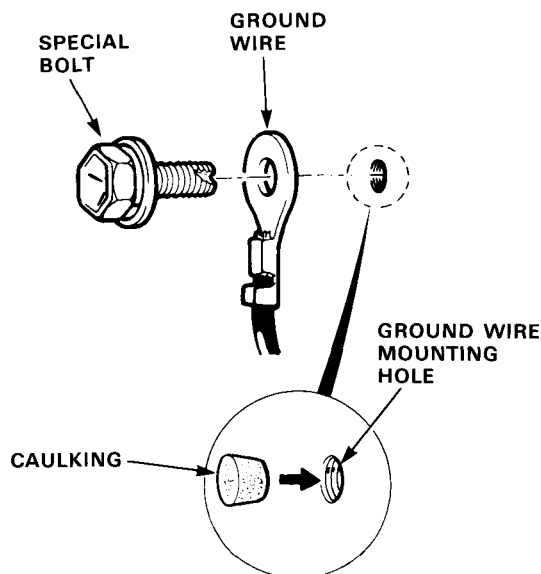

Avoid puttying as much as possible when repairing a new car. Use alternative methods as much as possible.

**⚠ WARNING**

- Most paints contain substances that are harmful if inhaled or swallowed. Read the paint label before opening the container. Spray paint only in a well ventilated area.
- Cover spilled paint with sand, or wipe it up at once.
- Wear an approved respirator, gloves, eye protection and appropriate clothing when painting. Avoid contact with skin.
- If paint gets in your mouth or on your skin, rinse or wash thoroughly with water. If paint gets in your eyes, flush with water and get prompt medical attention.
- Paint is flammable. Store it in a safe place, and keep it away from sparks, flames or cigarettes.

Operation	Tools/Materials	Procedure	Remarks
1. Prep the repair area.	Double-action sander, #80 sandpaper.	Sand the area with a double-action sander and #80 sandpaper. Clean with wax and grease remover.	
2. Apply putty. NOTE: Putty can be applied after priming as described in step 4.	Epoxy-based putty. • Mix the putty and hardener according to the manufacturer's directions. Polyester resin putty. Body filler.	Apply in several thin coats if necessary. Try to avoid leaving pinholes in the putty, • Follow the manufacturer's recommendations for preparation.	
3. Sand and clean the puttied area.	Double-action sander, orbital sander, hand sanding file, #80, #120, #240 sandpaper, wax and grease remover, shop towels.	Rough-sand the area with a double-action sander and #80 sandpaper, then sand with #120 sandpaper. Featheredge with #240 sandpaper. Clean with wax and grease remover.	
4. Coat with primer. NOTE: Apply to bare sheet metal and puttied area.	Epoxy-based primer and hardener, epoxy thinner. • Mix and thin the primer according to the manufacturer's directions.	Apply 2-4 coats, allowing sufficient flash time between coats. Force dry at 140-158°F (60-70°C) for at least 30 minutes.	Spray to a thickness of 30-35 microns
5. Sand and clean the whole area.	Double-action sander, #300, #400 sandpaper, wax and grease remover, shop towels.	Sand the repair area by hand with #300, #400 sandpaper. Blow off with compressed air. Clean with wax and grease remover.	
6. Apply intermediate coat to the whole area to be repainted.	Polyester/urethane resin primer/surfacer or top-coat enamel. • Mix and thin the primer according to the manufacturer's directions.	Apply 2-4 coats, allowing sufficient flash time between coats. Force dry at 140-158°F (60-70°C) for at least 30 minutes.	Spray to a thickness of 30-35 microns
7. Sand and clean the whole area to be repainted.	Hand sanding file, double-action sander, #400, #600 sandpaper, wax and grease remover, shop towels.	Sand the repair area by hand with #400 sandpaper until it's level. Sand the whole area to repainted with #400-600 sandpaper. Clean with wax and grease remover.	
8. Top-coat the whole area to repainted.	Acrylic urethane resin top coat paint, hardener, and thinner. • Mix and thin the paint according to the manufacturer's directions.	Apply 2-4 coats allowing sufficient flash time between coats. Force dry at 140-158°F (60-70°C) for at least 30 minutes.	Spray to a thickness of 40-50 microns

# General Information

## Bumper and Door Reinforcement Beams

Bumper and door reinforcement beams used on Honda automobiles are made from high strength steel.

Should high strength steel be heated, the strength of the steel will be reduced. If high strength steel is damaged, as in an accident where the bumper or door reinforcement beams are bent, the beams may crack should any attempt be made to straighten them.

For this reason, bumper and door reinforcement beams should **never** be repaired; they should be **replaced** if they become damaged.

NOTE: If a door beam is damaged, the whole door panel assembly should be replaced.

**FRONT BUMPER REINFORCEMENT BEAM**

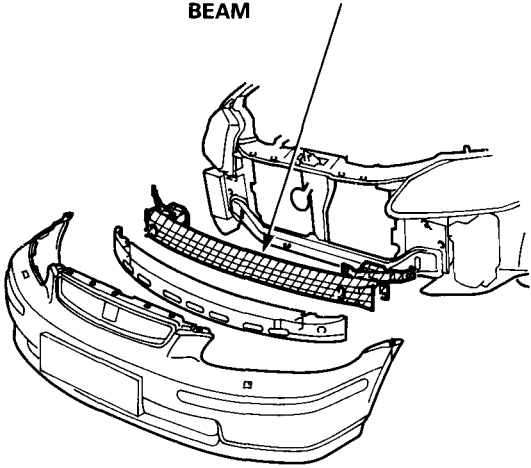

**REAR BUMPER REINFORCEMENT BEAM**

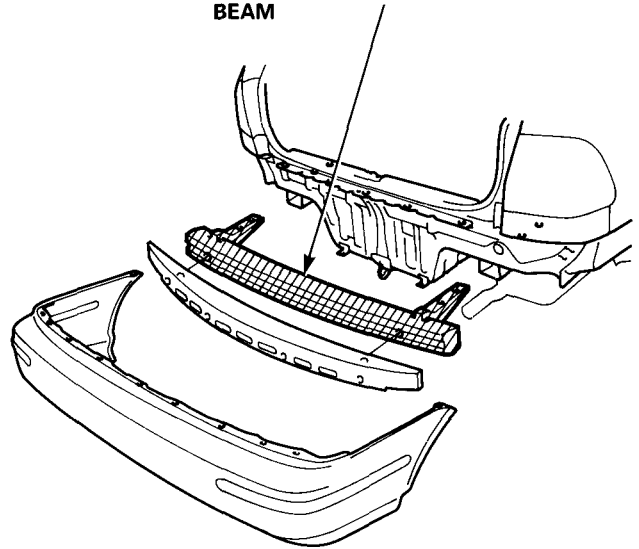

**4-Door:**

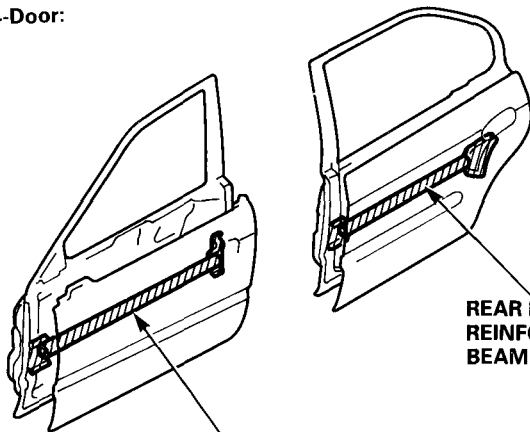

**FRONT DOOR REINFORCEMENT BEAM**

**REAR DOOR REINFORCEMENT BEAM**

**3-Door/2-Door:**

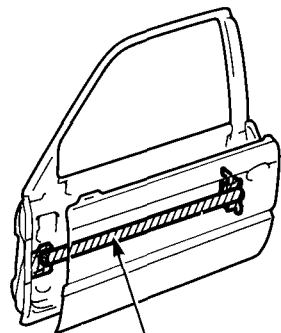

**DOOR REINFORCEMENT BEAM**

# General Information

## Construction

4-Door .....	4-2
3-Door .....	4-3
2-Door .....	4-4

## Exterior Body Parts

Replacement .....	4-5
-------------------	-----

## Front Bulkhead

Description .....	4-6
Mass Production Body	
Welding Diagram .....	4-6
Replacement .....	4-7

## \*Front Wheelhouse/Damper Housing

Description .....	4-10
Mass Production Body	
Welding Diagram .....	4-10
Replacement .....	4-11

## \*Front Side Frame

Description .....	4-15
Mass Production Body	
Welding Diagram .....	4-15
Replacement .....	4-16

## \*Front Side Outrigger

Description .....	4-20
Mass Production Body	
Welding Diagram .....	4-20
Replacement .....	4-21

## \*Front Pillar (Outer Panel)

Description .....	4-24
Mass Production Body	
Welding Diagram .....	4-24
Replacement .....	4-25

## \*Windshield Lower

Description .....	4-28
Mass Production Body	
Welding Diagram .....	4-28
Replacement .....	4-29

## Side Sill (Outer Panel)

Description .....	4-31
Mass Production Body	
Welding Diagram .....	4-31
Replacement .....	4-33

## Roof Panel

Description .....	4-36
Mass Production Body	
Welding Diagram .....	4-36
Replacement .....	4-37

## Rear Side Outer Panel

Description .....	4-41
Mass Production Body	
Welding Diagram .....	4-41
Replacement .....	4-44

## Rear Panel

Description .....	4-49
Mass Production Body	
Welding Diagram .....	4-49
Replacement .....	4-50

## Rear Floor

Description .....	4-53
Mass Production Body	
Welding Diagram .....	4-53
Replacement .....	4-54

## Rear Floor Cross-member

Description .....	4-57
Mass Production Body	
Welding Diagram .....	4-57
Replacement .....	4-57

Items marked with an asterisk (\*) include SRS components; special caution is required when servicing.

## Body Welding Symbols

The symbols in the mass production body welding diagrams and in the replacement illustrations carry following meaning:

**〈Mass Production Body Welding Diagram〉**

- \* : Spot welding
- ▽ : MIG welding
- × : 2-plate welding
- ⊗ : 3-plate welding
- ⊠ : 4-plate welding
- P= Spot welding pitch  
Unit: mm (in)
- ( ) The number of the spot welding

**〈Replacement Illustration〉**

- X : Spot welding
- : MIG welding

NOTE: The welding symbols in the illustrations don't show exact welding locations. For exact welding locations, refer to the mass production body welding diagrams.

# Construction

## 4-Door

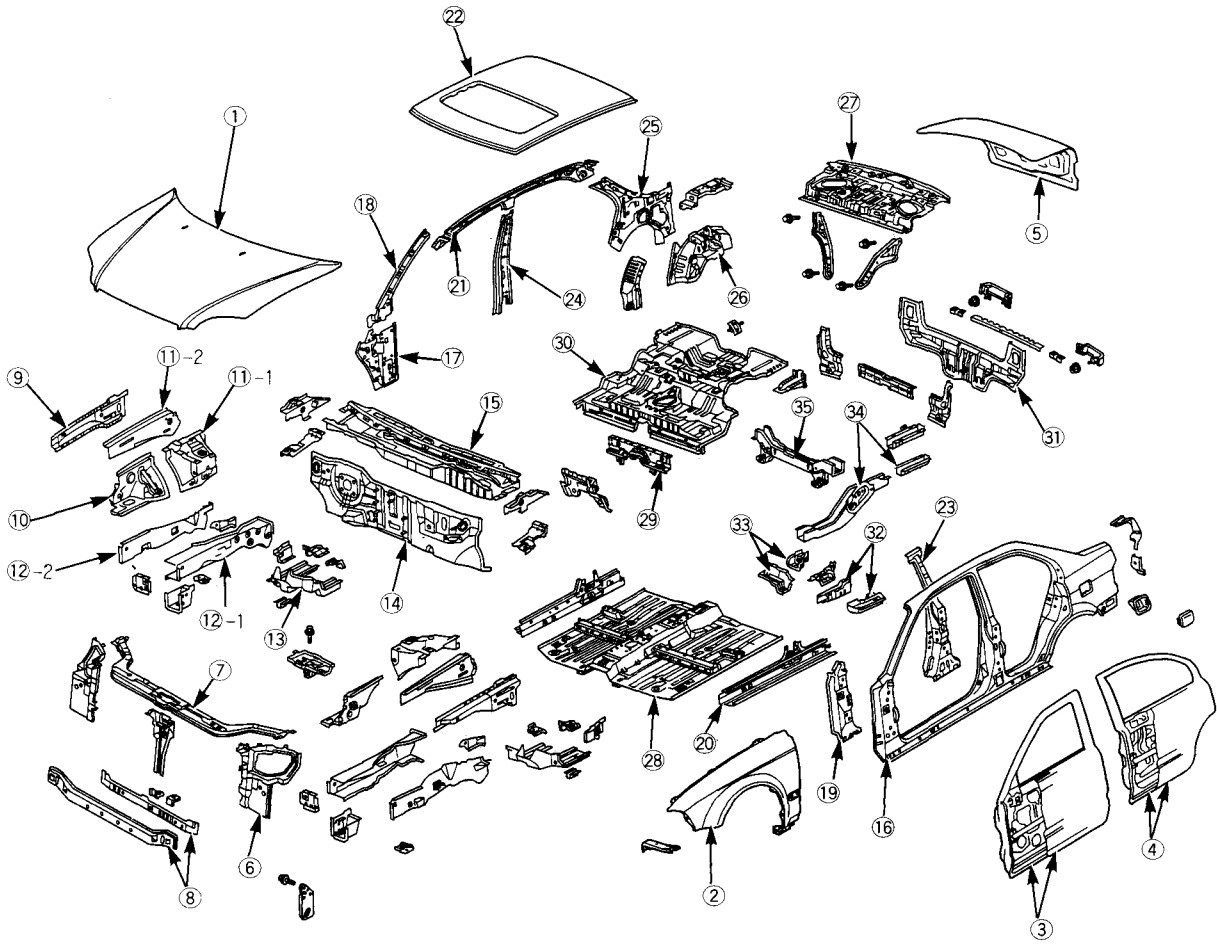

NOTE: Be sure to use epoxy-based putty and primer surfacer to make any repairs on paint coats or zinc-plated sheet metal (see page 3-3).

No.	Part Name	Zinc-plated	No.	Part Name	Zinc-plated
①	Hood	○	18	Front Pillar Inner Upper	
②	Front Fender	○	19	Front Pillar Stiffener	○
③	Front Door Panel/Skin	○	20	Inside Sill	○
④	Rear Door Panel/Skin	○	21	Roof Side Rail	
⑤	Trunk Lid	○	22	Roof Panel	
⑥	Front Side Bulkhead	○	23	Center Pillar Stiffener	
⑦	Bulkhead Upper Frame	○	24	Center Pillar Inner	
⑧	Front Lower Cross-member	○	25	Rear Inner Panel	○
⑨	Wheelhouse Upper Member		26	Rear Wheelhouse	○
⑩	Front Wheelhouse		27	Parcel Shelf	
11-1	Damper Housing	○	28	Front Floor	○
11-2	Wheelhouse Extension		29	Middle Floor Cross-member	○
12-1	Front Side Frame		30	Rear Floor	○
12-2	Front Side Back Plate	○	31	Rear Panel	○
13	Front Side Outrigger		32	Side Sill Extension	○
14	Dashboard Lower	○	33	Rear Frame Extension	○
15	Dashboard Upper	○	34	Rear Frame	○
16	Outer Panel	○	35	Rear Floor Cross-member	○
17	Front Pillar Inner Lower	○			



# 3-Door

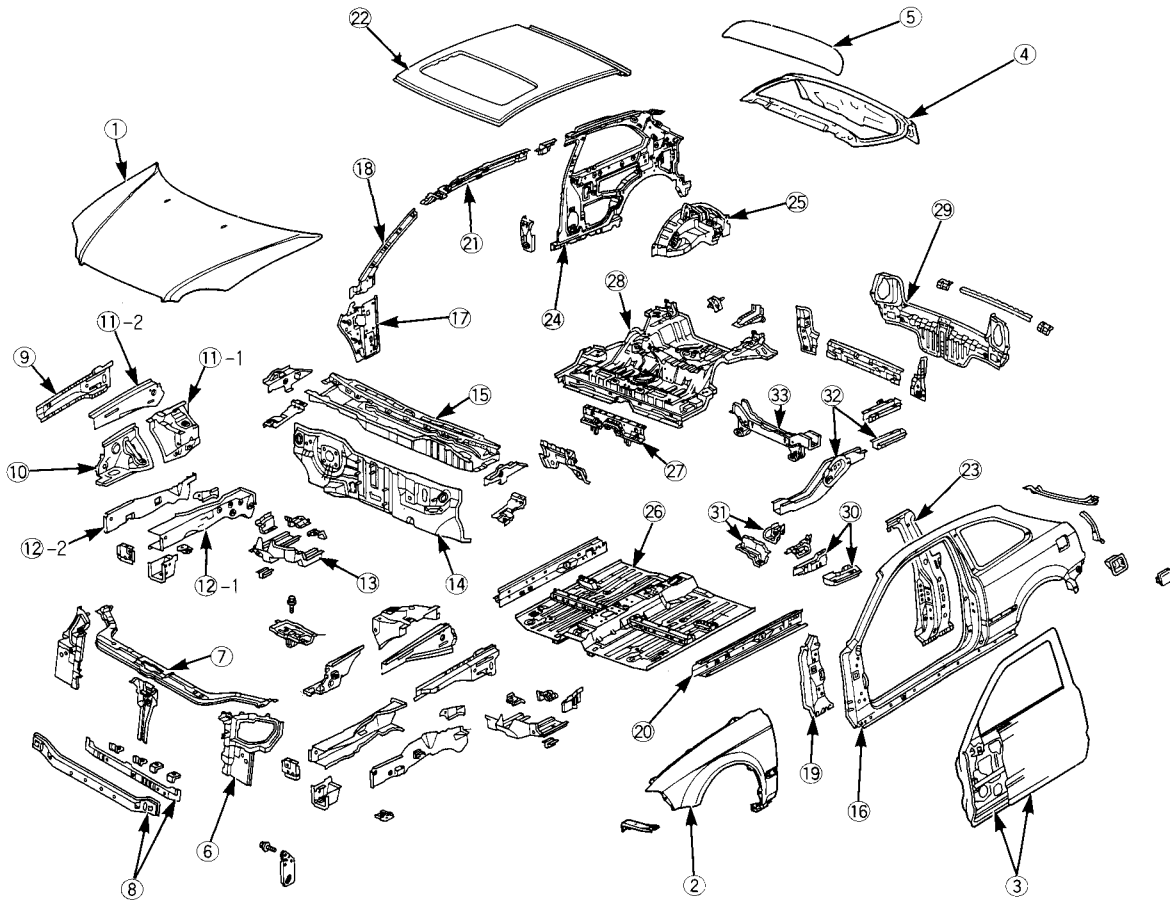

NOTE: Be sure to use epoxy-based putty and primer surfacer to make any repairs on paint coats or zinc-plated sheet metal (see page 3-3).

No.	Part Name	Zinc-plated	No.	Part Name	Zinc-plated
①	Hood	○	①7	Front Pillar Inner Lower	○
②	Front Fender	○	①8	Front Pillar Inner Upper	○
③	Door Panel/Skin	○	①9	Front Pillar Stiffener	○
④	Hatch	○	②0	Inside Sill	○
⑤	Hatch Spoiler	○	②1	Roof Side Rail	○
⑥	Front Side Bulkhead	○	②2	Roof Panel	○
⑦	Bulkhead Upper Frame	○	②3	Center Pillar Stiffener	○
⑧	Front Lower Cross-member	○	②4	Rear Inner Panel	○
⑨	Wheelhouse Upper Member	○	②5	Rear Wheelhouse	○
⑩	Front Wheelhouse	○	②6	Front Floor	○
⑪-1	Damper Housing	○	②7	Middle Floor Cross-member	○
⑪-2	Wheelhouse Extension	○	②8	Rear Floor	○
⑫-1	Front Side Frame	○	②9	Rear Panel	○
⑫-2	Front Side Back Plate	○	③0	Side Sill Extension	○
⑬	Front Side Outrigger	○	③1	Rear Frame Extension	○
⑭	Dashboard Lower	○	③2	Rear Frame	○
⑮	Dashboard Upper	○	③3	Rear Floor Cross-member	○
⑯	Outer Panel	○			

# Construction

## 2-Door

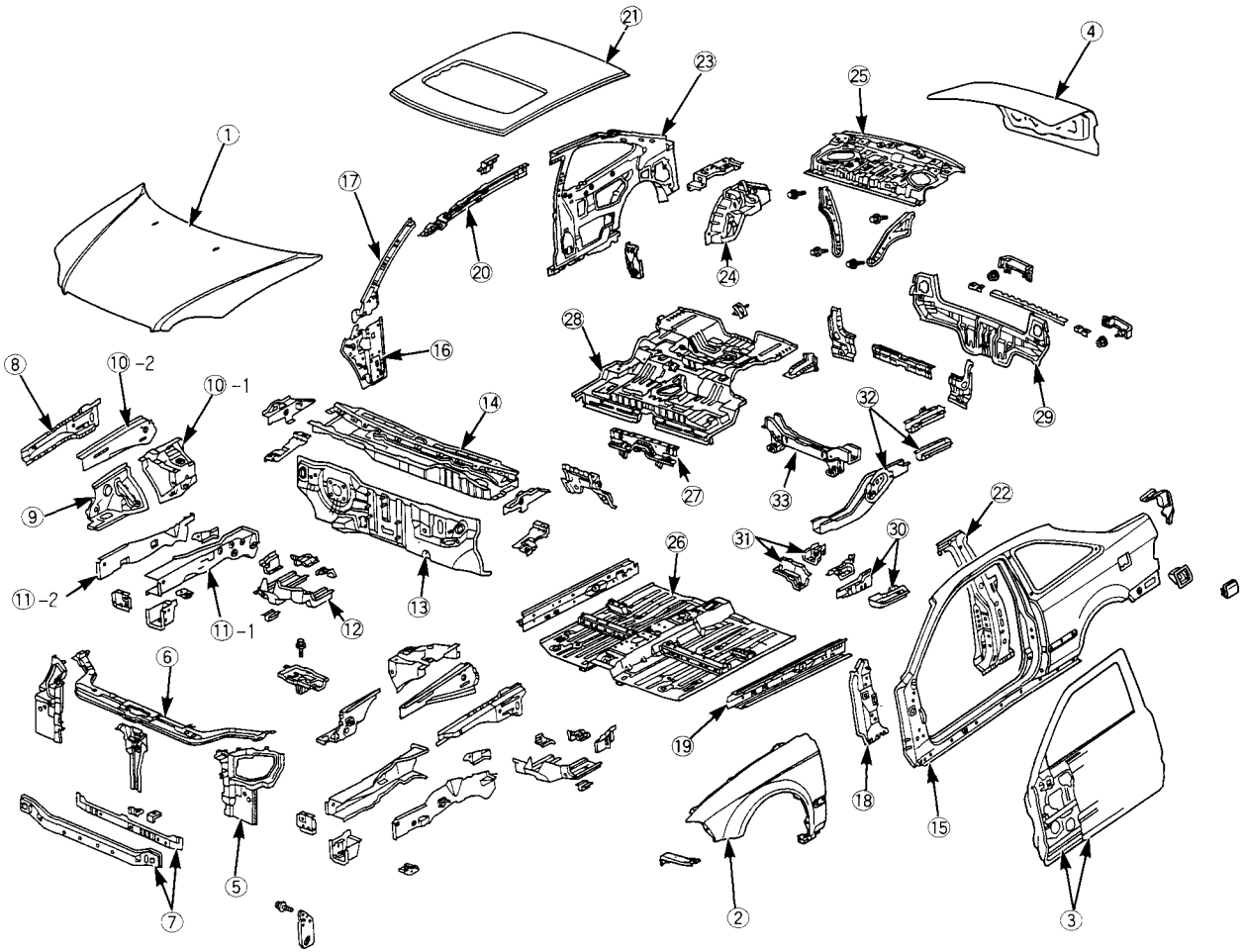

NOTE: Be sure to use epoxy-based putty and primer surfacer to make any repairs on paint coats or zinc-plated sheet metal (see page 3-3).

No.	Part Name	Zinc-plated	No.	Part Name	Zinc-plated
①	Hood	○	17	Front Pillar Inner Upper	○
②	Front Fender	○	18	Front Pillar Stiffener	○
③	Door Panel/Skin	○	19	Inside Sill	○
④	Trunk Lid	○	20	Roof Side Rail	○
⑤	Front Side Bulkhead	○	21	Roof Panel	○
⑥	Bulkhead Upper Frame	○	22	Center Pillar Stiffener	○
⑦	Front Lower Cross-member	○	23	Rear Inner Panel	○
⑧	Wheelhouse Upper Member	○	24	Rear Wheelhouse	○
⑨	Front Wheelhouse	○	25	Parcel Shelf	○
10-1	Damper Housing	○	26	Front Floor	○
10-2	Wheelhouse Extension	○	27	Middle Floor Cross-member	○
11-1	Front Side Frame	○	28	Rear Floor	○
11-2	Front Side Back Plate	○	29	Rear Panel	○
12	Front Side Outrigger	○	30	Side Sill Extension	○
13	Dashboard Lower	○	31	Rear Frame Extension	○
14	Dashboard Upper	○	32	Rear Frame	○
15	Outer Panel	○	33	Rear Floor Cross-member	○
16	Front Pillar Inner Lower	○			

# Exterior Body Parts

## Replacement

Mounting bolts Torque:

6X 1.0 mm : 9.8 N-m (1.0 kgf-m, 7.2 lbf-ft)

8X 1.25 mm : 22 N-m (2.2 kgf-m, 16 lbf-ft)

\*8X 1.25 mm: 28 N-m (2.9 kgf-m, 21 lbf-ft)

12X 1.25 mm: 54 N-m (5.5 kgf-m, 40 lbf-ft)

▶: Sealing locations

NOTE: Seal the following areas to prevent water leak and rust.

Mastic sealer: 3M #08654

Use materials above or equivalents.

3-Door:

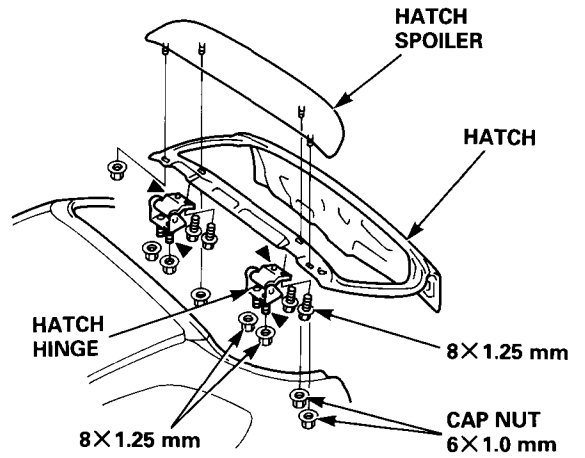

4-Door/2-Door

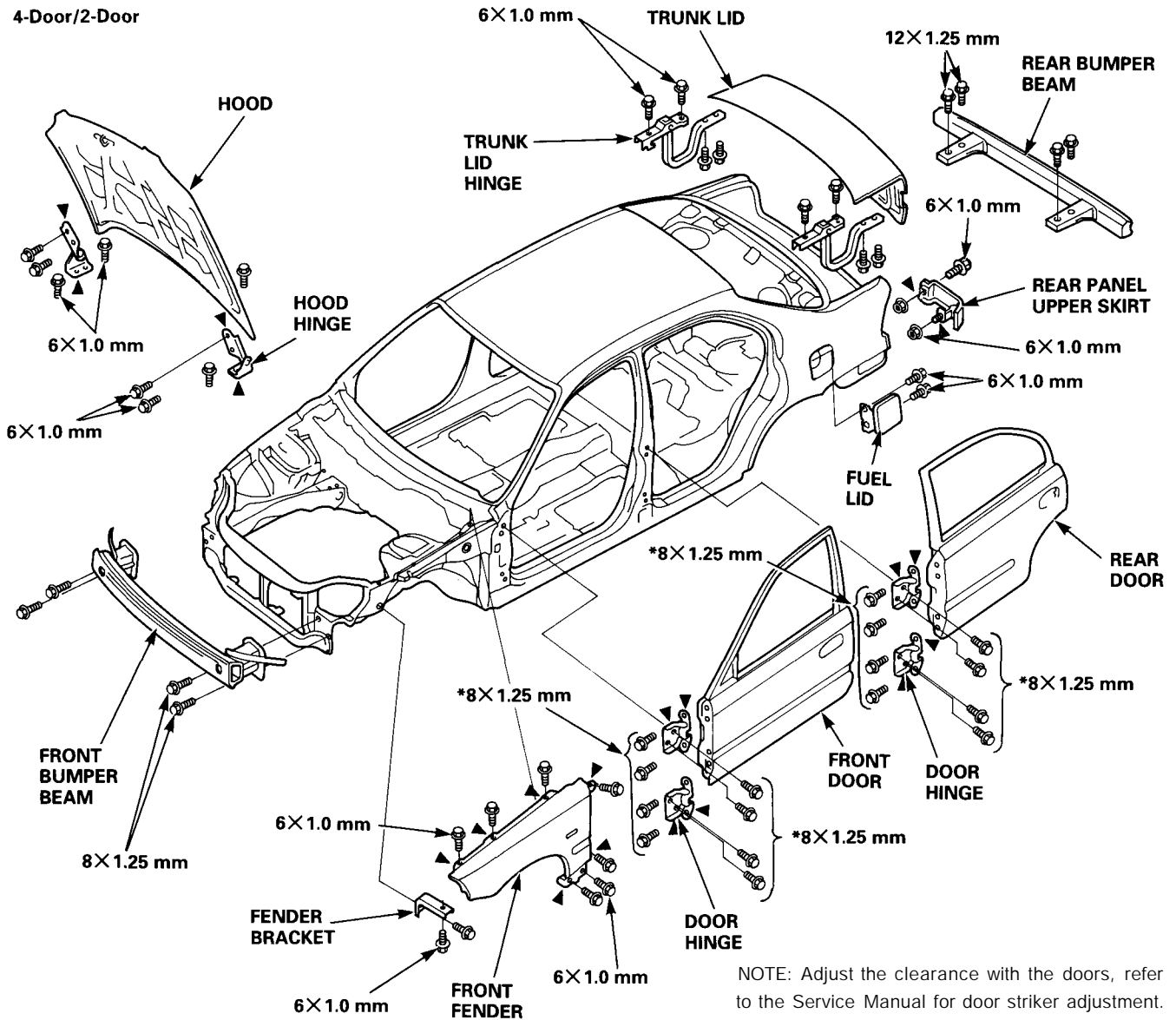

NOTE: Adjust the clearance with the doors, refer to the Service Manual for door striker adjustment.

# Front Bulkhead

## Description

The front bulkhead is joined to the front wheelhouse and the front side frame. It forms the base for the headlights and other parts and maintains the rigidity of the front section of the body. Pay particular attention to twists and parallelism, and check the mounting of related parts when welding.

## Mass Production Body Welding Diagram

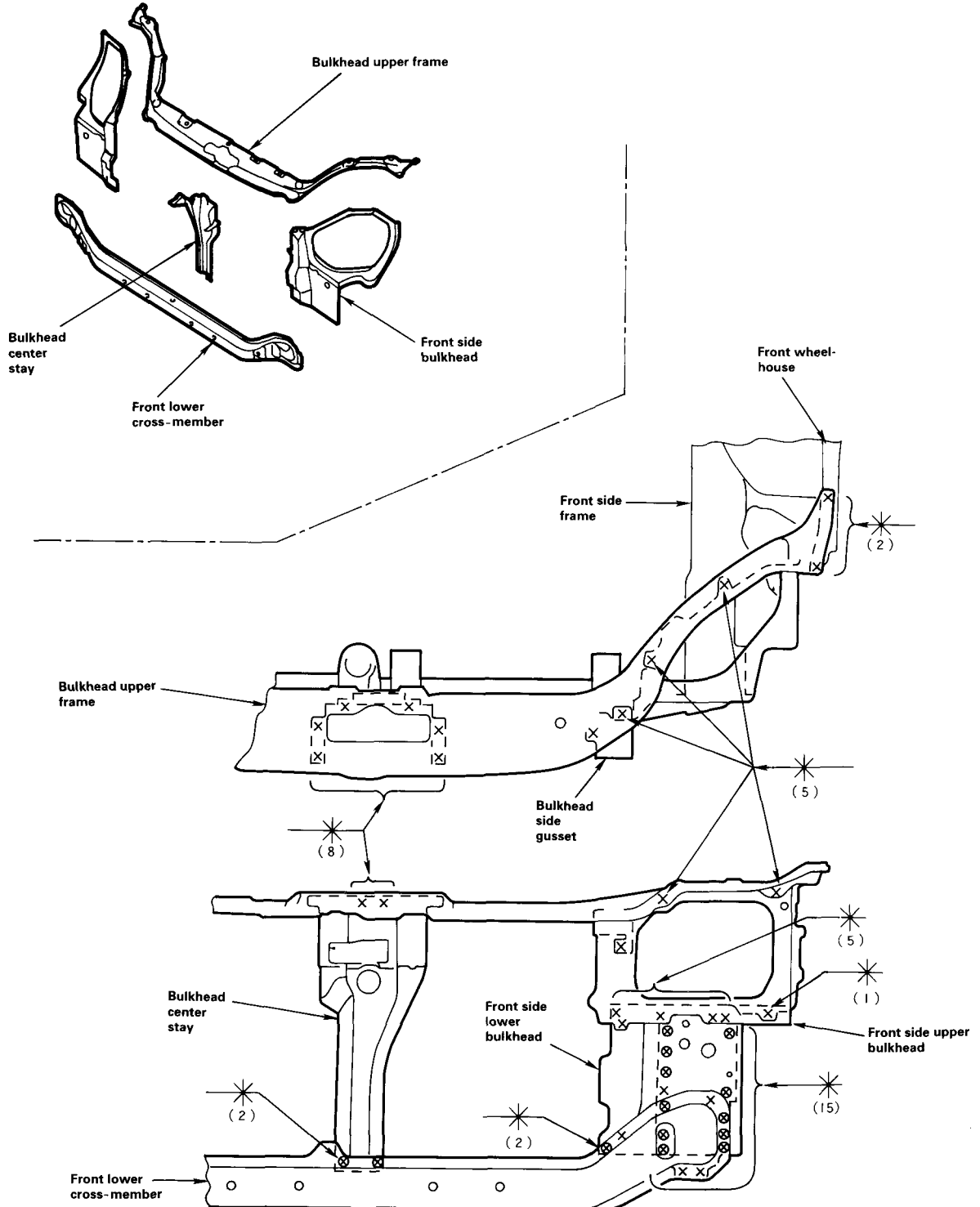

## Replacement

1. Remove the related parts.

- Front bumper
- Hood
- Right and left headlights
- Right and left front fenders
- Radiator, condenser
- Hood latch

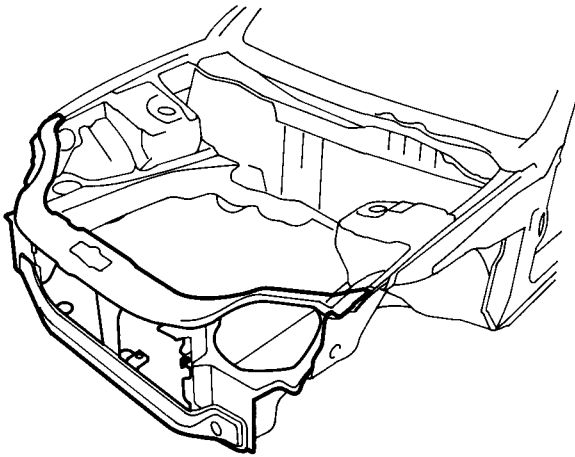

2. Roughly pull out and straighten the damaged area.

- Check the damage to the front wheelhouse and front side frame before removing the front bulkhead. Use the frame straightener to roughly pull out and repair the damaged bulkhead before removing the bulkhead.

NOTE: Check the fit of the door, taking care not to pull the damaged area out more than necessary.

- Use the horizontal pinch weld clamps and attach the car to the frame straightener at the clamping points securely.

3. Keep the body level.

Jack up the body, and place safety stands at the four designated places of the side sills.

NOTE: Refer to the Civic Service Manual for safety stand location points.

4. Cut and pry off the front bulkhead.

- Center punch around the spot weld imprints.
- Use the special spot cutter to drill holes at the spot weld nuggets on the front wheelhouse and front side frame.

NOTE: When drilling holes be careful not to drill down to the front wheelhouse or front side frame themselves.

- Cut off the bulkhead with an air chisel, leaving the welding flanges intact.
- Level and finish the burrs from the pried off spot welds with a disc sander.

**⚠ WARNING** To prevent eye injury, wear goggles or safety glass whenever sanding, cutting or grinding.

**BULKHEAD UPPER FRAME**

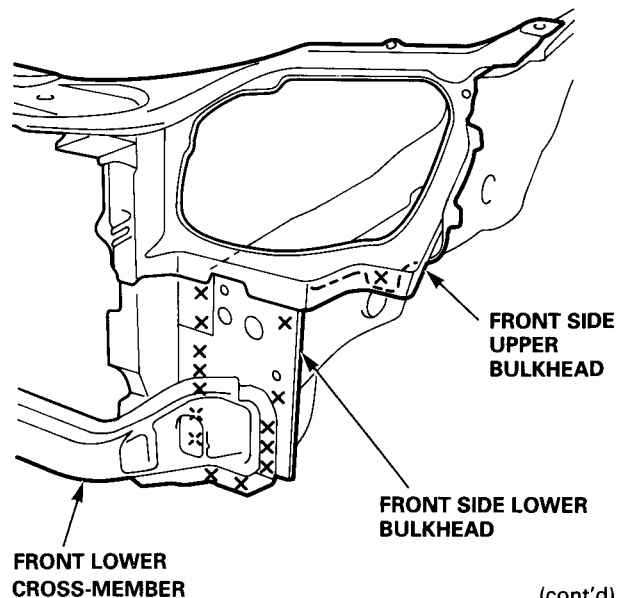
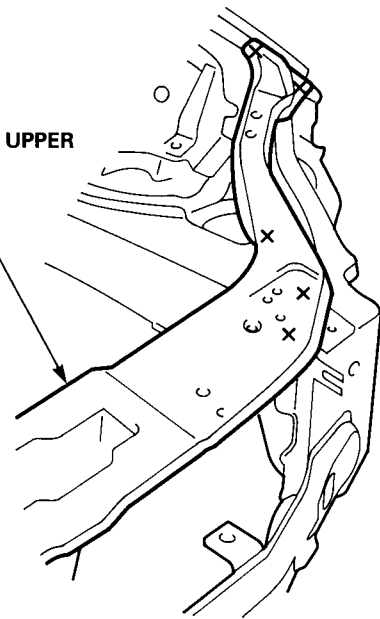

(cont'd)

# Front Bulkhead

## Replacement (cont'd)

- Mold the damaged related parts.
  - Replace the tie down bracket, if necessary.
  - Use a hammer and dolly to mold the damaged areas of the front wheelhouse and front side frame.
  - Even out the welding flanges with a hammer and dolly.
  - Fill all drilled holes by MIG or gas welding.

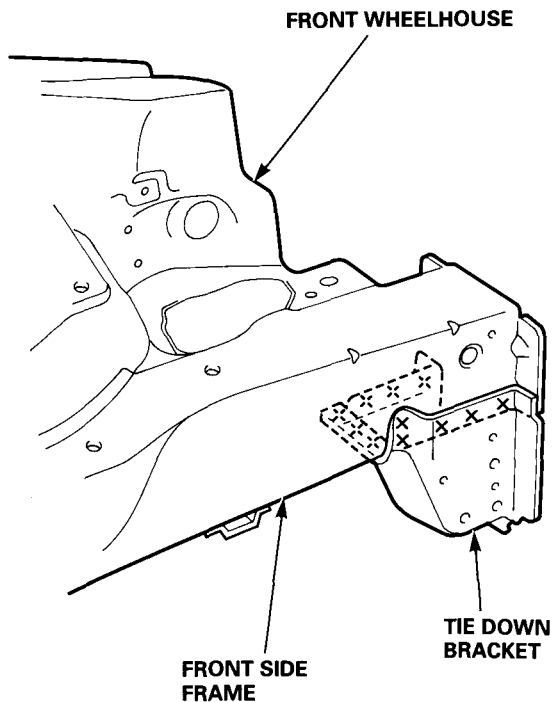

- Set the new front bulkhead.
  - Grind both sides of the welding section of the bulkhead with a sander to remove the undercoat and expose the steel plate.

**WARNING** To prevent eye injury, wear goggles or safety glasses whenever sanding, cutting or grinding.

- Clamp both the right and left sides with the vise-grips as shown.

NOTE: Apply the spot sealer to the welding surface when spot welding.

- Check the front bulkhead position using the body dimensional drawings (see [section 6](#)).

- Tack weld the new front bulkhead.

**WARNING** To prevent eye injury and burns when welding, wear an approved welding helmet, gloves and safety shoes.

Spot weld the clamped sections.

NOTE: Make sure that the right and left bulkheads are in line with each other.

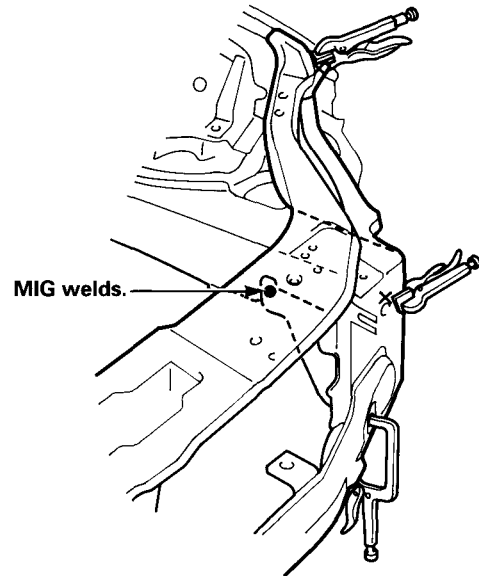

- Measure the front compartment diagonally. Measure the front compartment diagonally with a tracking gauge or convex tool as shown to check it for twisting or bending.

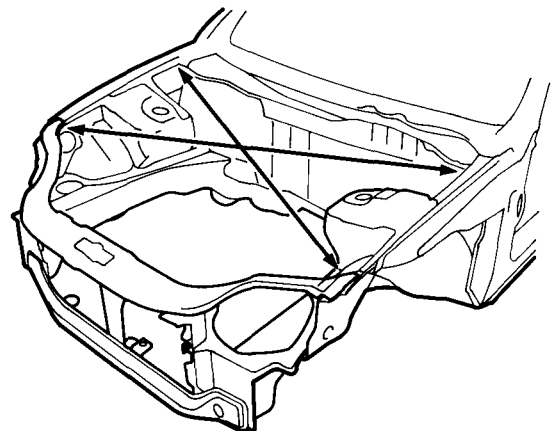

- Temporarily assemble the hood, headlight and front fender, then check the clearances and level differences.

10. Perform the main welding.

- Spot weld the bulkhead as shown.
- Make 20% to 30% more spot welds than there were holes drilled.

**⚠ WARNING** To prevent eye injury and burns when welding, wear an approved welding helmet, gloves and safety shoes.

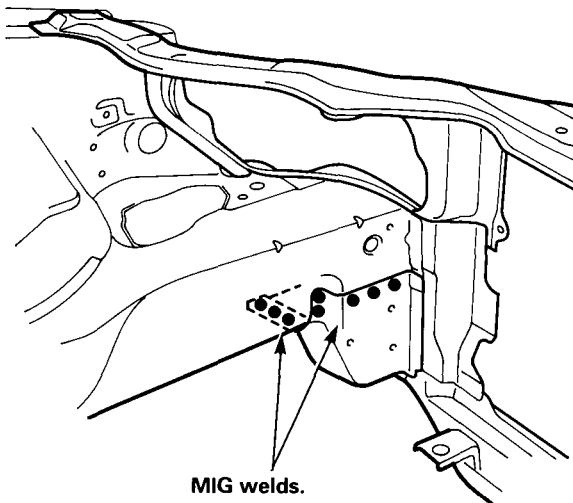
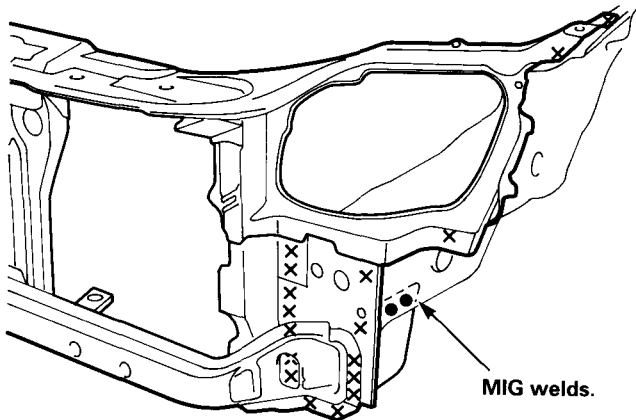

11. Finish the welds.

Use a hammer and dolly to even out the front wheelhouse and front side frame flanges for a close fit with the surface of the front bulkhead.

12. Apply the undercoat (see [section 7](#)).

13. Attach the front fender.

14. Lower the body.

NOTE: Tighten the wheel nuts to the specified torque.  
Torque: 108 N-m (11.0 kgf-m, 79.6 lbf-ft)

15. Apply the paint.

See Paint Repair section.

**⚠ WARNING**

- Ventilate when spraying paint. Most paint contains substances that are harmful if inhaled or swallowed. Read the paint label before opening the paint container.
- Avoid contact with skin. Wear an approved respirator, gloves, eye protection and appropriate clothing when painting.
- Paint is flammable. Store it in a safe place, and keep it away from sparks, flames or cigarettes.

16. Install the related parts.

17. Inspect, check, and make adjustments.

- Adjust the headlight aim.
- Check that the electrical components light up and operate properly.
- Replenish radiator coolant and inspect for leaks.

# Front Wheelhouse/Damper Housing

## Description

The front wheelhouse component is constructed as a unit with the front damper housing. Therefore, replacement of the component affects the front wheel alignment. When assembling it, either use a positioning jig or follow dimensions on the frame repair chart for positioning. Weld carefully.

## Mass Production Body Welding Diagram

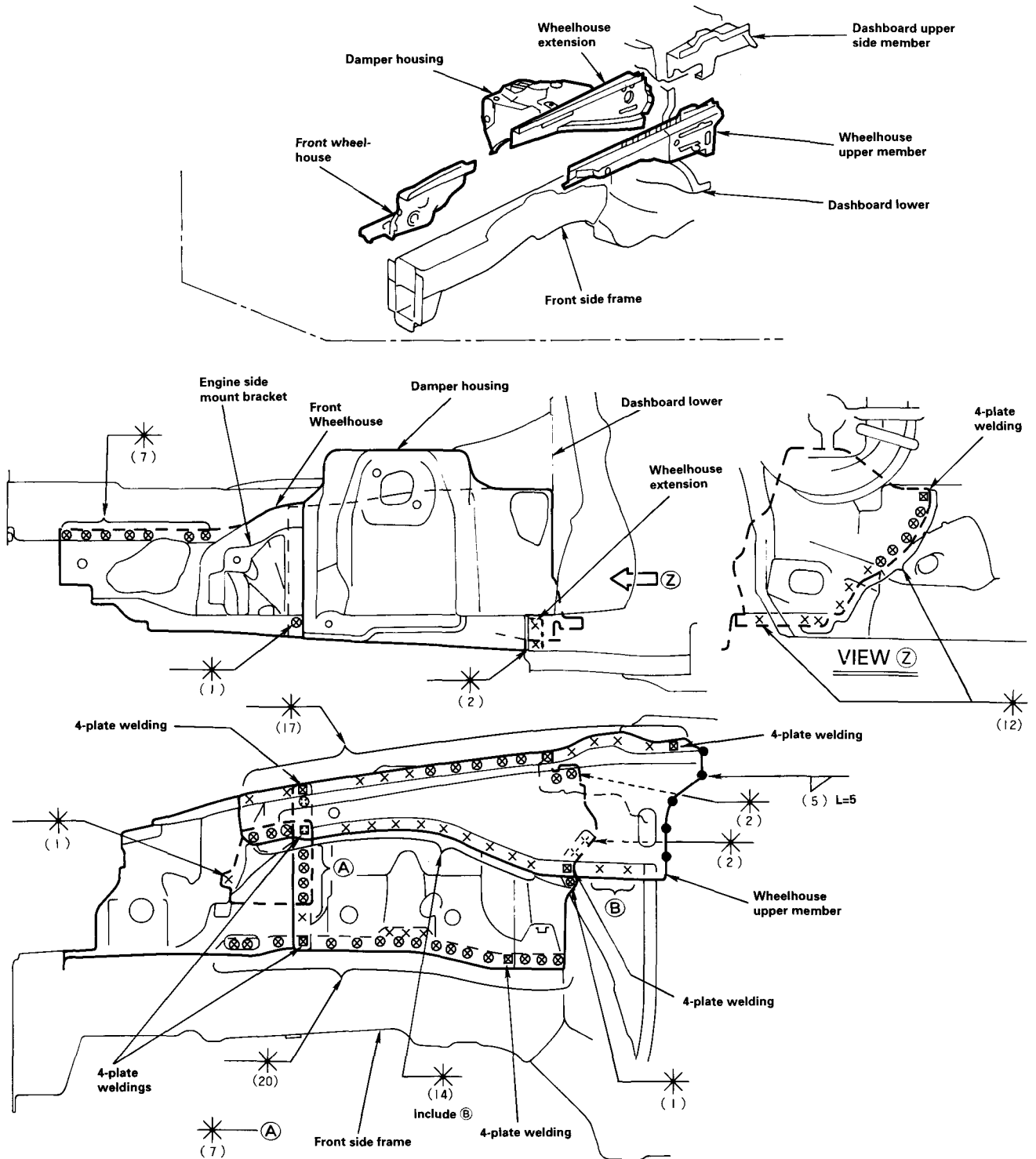



## Replacement

1. Remove the related parts.
  - Parts to be removed when removing the front bulkhead
  - Parts on passenger side of lower dashboard which are especially flammable
  - Electrical accessories in engine compartment and wire harnesses.

NOTE: See the Civic Service Manual, for removal and installation of the engine, front suspension and brakes.

2. Pull out and straighten the damaged area to approximately the original shape.
  - Attach the car to the frame straightener by tightening the underbody clamps at the horizontal pinch weld points.

NOTE: Refer to the Civic Service Manual for safety stand location points.

- Before cutting off the damaged sections, pull them out so that they are restored to the original shape.
- Do not pull out more than necessary.
- Pull out and straighten the damaged area of the lower dashboard, front pillar, and other parts.
- After pulling, check the damper housing position using the body dimensional drawings (see [section 6](#)) and positioning jig (see page [1-8](#)).

NOTE: Check the condition of the door and hinges.

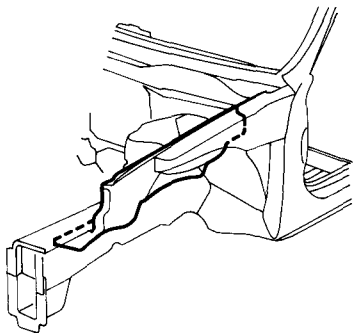

3. Peel off the undercoat.

Heat the undercoat at the weld areas of the wheelhouse and front side frame with a gas torch, and peel off the undercoat with a metal spatula.

**CAUTION:** Be careful not to burn the fittings inside the passenger compartment and dashboard insulator when heating.

4. When replacing the front wheelhouse.
  - Center punch around the spot weld imprints on the front side frame and damper housing.
  - Drill holes in the center punched areas using a spot cutter.
  - Using a chisel, pry off the welded flange.
  - Level and finish the burrs on the welding surfaces with a sander.

Left side:

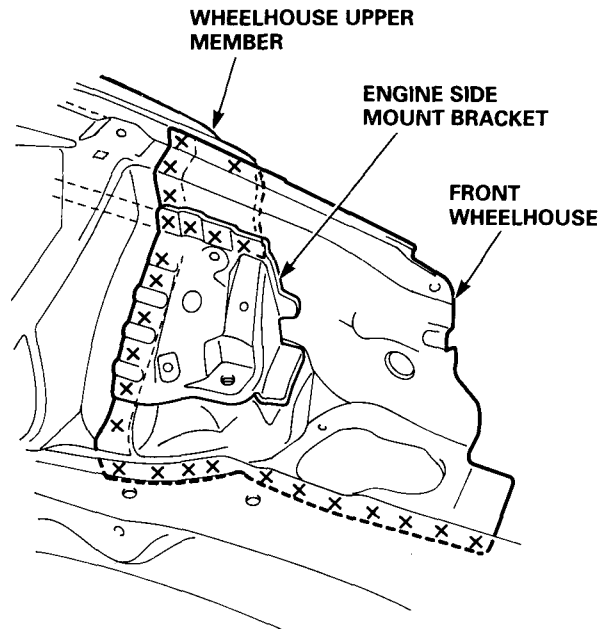

Right side:

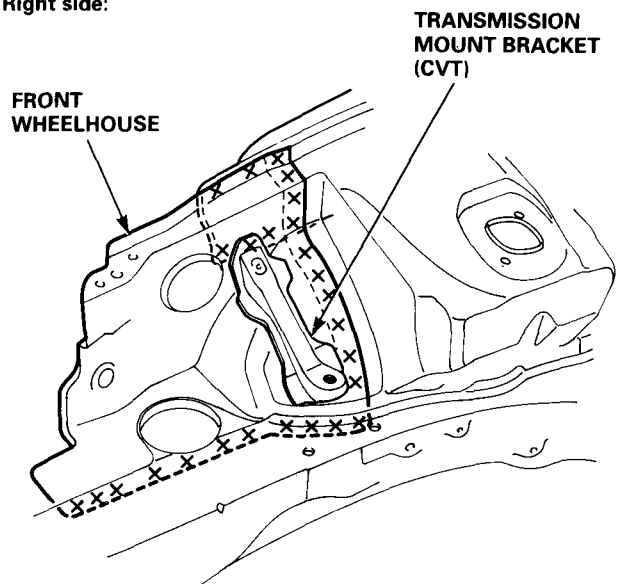

(cont'd)

# Front Wheelhouse/Damper Housing

## Replacement (cont'd)

5. When replacing the damper housing and front wheelhouse as an assembly.

-1 Remove the wheelhouse upper member.

- Center punch around the spot weld imprints.
- Use the special spot cutter to drill holes at the spot weld nuggets.
- Remove the MIG weld flange with a disc sander.

**▲ WARNING** To prevent eye injury, wear goggles or safety glasses whenever sanding, cutting or grinding.

- Using a chisel, pry off the welded flange from the front pillar and damper housing.

NOTE: Remove the wheelhouse upper member carefully so they can be reused.

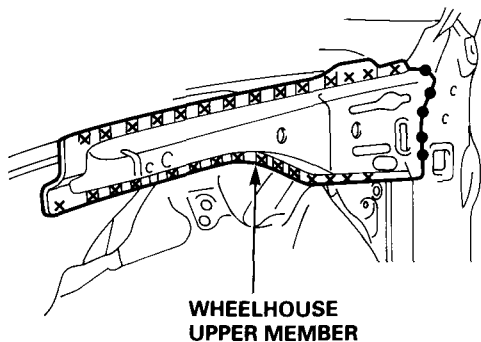

-2 Using a spot cutter, drill holes in the spot welded area on the front side frame and dashboard upper side member.

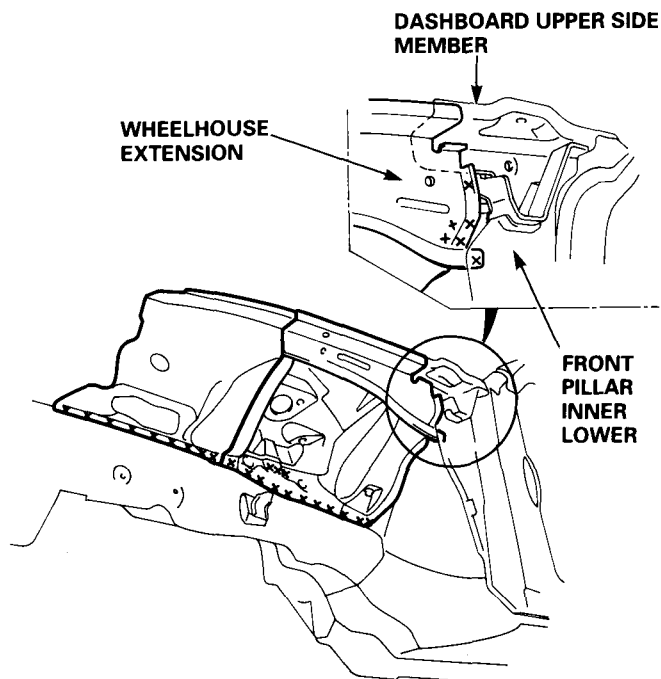
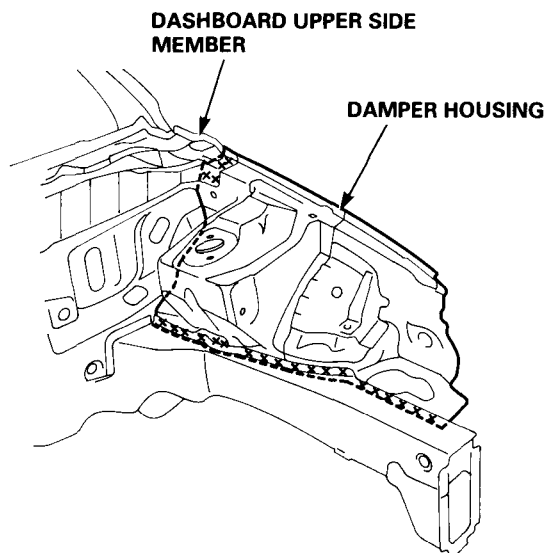

-3 From the passenger compartment side, drill holes in the spot welded area with a 5 mm (0.2 in).

NOTE: Drill holes completely through the parts since the replacement damper housing will be welded by MIG welding.

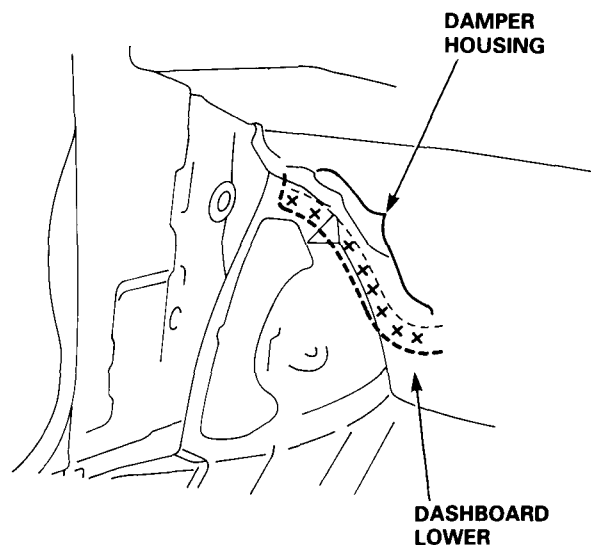

6. Mold the related parts.
  - Level and finish the burrs left on the welding surfaces with a sander.
  - Fill all drilled holes by MIG or gas welding.
  - Use a hammer and dolly to even out the welded areas of the lower dashboard, front side frame and dashboard upper side member.

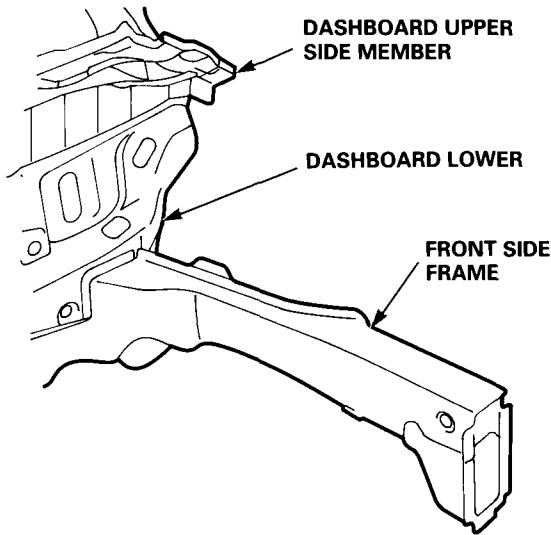

7. Set the new front wheelhouse and damper housing.
  - Apply body paint to both sides of the new front wheelhouse and damper housing.
  - See Paint Repair section.

**▲ WARNING**

- Ventilate when spraying paint. Most paint contains substances that are harmful if inhaled or swallowed. Read the paint label before opening the paint container.
- Avoid contact with skin. Wear an approved respirator, gloves, eye protection and appropriate clothing when painting.
- Paint is flammable. Store it in a safe place, and keep it away from sparks, flames or cigarettes.
- Remove the undercoat from both sides of the welding section and expose the steel plate using a disc sander.

**▲ WARNING**

To prevent eye injury, wear goggles or safety glasses whenever sanding, cutting or grinding.

- Clamp to the front side frame with vise-grips and squill vises.

NOTE: Apply the spot sealer to the welding surface when spot welding.

- Clamp the front bulkhead with vise-grips.
- Measure the front compartment diagonally.

NOTE: Use of a positioning jig is recommended (see page 1-8).

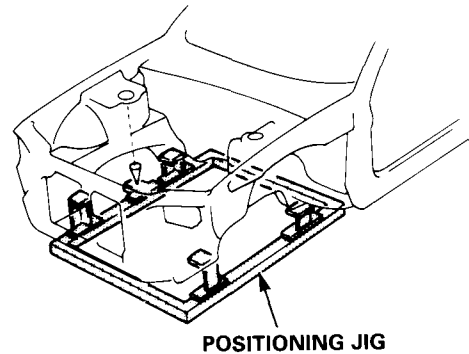

- Spot weld several points in the clamped sections, and temporarily attach the front wheelhouse and damper housing.

**▲ WARNING**

To prevent eye injury and burns when welding, wear an approved welding helmet, gloves and safety shoes.

8. Check the dimensions, temporarily install the hood, front fender and headlight, and check for differences in level and clearance.
  - Check the engine and transmission mount brackets position (see section 6).

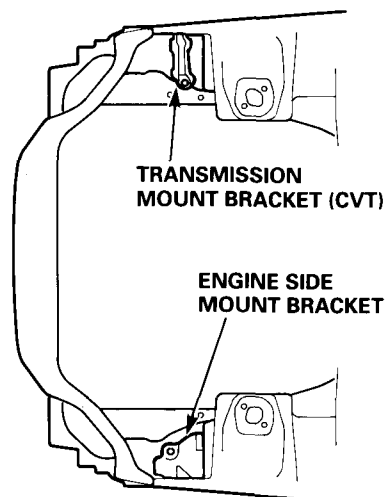

(cont'd)

# Front Wheelhouse/Damper Housing

## Replacement (cont'd)

9. Perform the main welding.
  - Weld as much as possible with the jig still mounted.

**⚠ WARNING** To prevent eye injury and burns when welding, wear an approved welding helmet, gloves and safety shoes.

- Make 20% to 30% more spot welds than there were holes drilled.

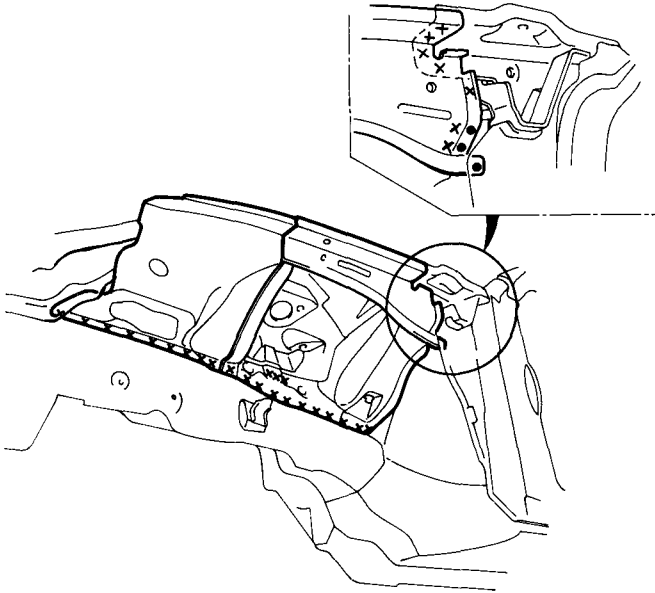

- Plug weld the holes areas of the dashboard lower and damper housing with a MIG welder.

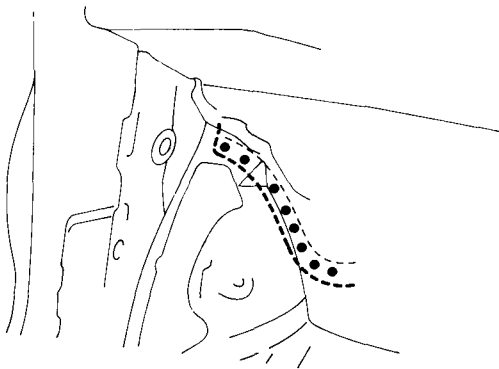

10. Weld the wheelhouse upper member.
  - When the upper member is to be reused, make MIG welds at the drilled holes.

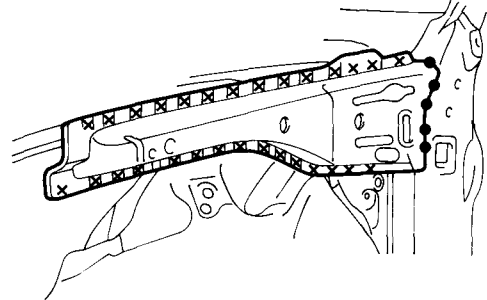

11. Finish the welded area.
  - Use a hammer and dolly to even out the side bulkhead and front side frame flanges for close fit with the surface of the front wheelhouse and damper housing.

12. Apply the sealer (see [section 5](#)).
  - Apply sealer to the mating surfaces of the lower dashboard and front side frame, etc.

13. Apply the paint.
  - See Paint Repair section.

**⚠ WARNING**

- **Ventilate when spraying paint.** Most paint contains substances that are harmful if inhaled or swallowed. Read the paint label before opening the paint container.
- **Avoid contact with skin.** Wear an approved respirator, gloves, eye protection and appropriate clothing when painting.
- **Paint is flammable.** Store it in a safe place, and keep it away from sparks, flames or cigarettes.

14. Apply the undercoat.
  - Undercoat the front floor, etc, and apply anti-rust agent to the inside of the welding section of the front side frame, lower dashboard, and upper member, etc (see [section 7](#)).

15. Install the related parts.
  - Install in the reverse order in which they were removed.

16. Inspect, check and make adjustment.
  - Measure the front wheel alignment.
  - Inspect the brake system.
  - Adjust the headlight aim.

# Front Side Frame

## Description

The front side frame acts as a base for the front suspension and is highly important in maintaining the rigidity of the front section. Pay careful attention to the position and dimensions of the weld joints and weld carefully.

## Mass Production Body Welding Diagram

**NOTE:**

- Replace the front side frame and front side outrigger as an assembly.
- When removing the outrigger, leave the inside sill extension attached to the dashboard lower side, if possible.

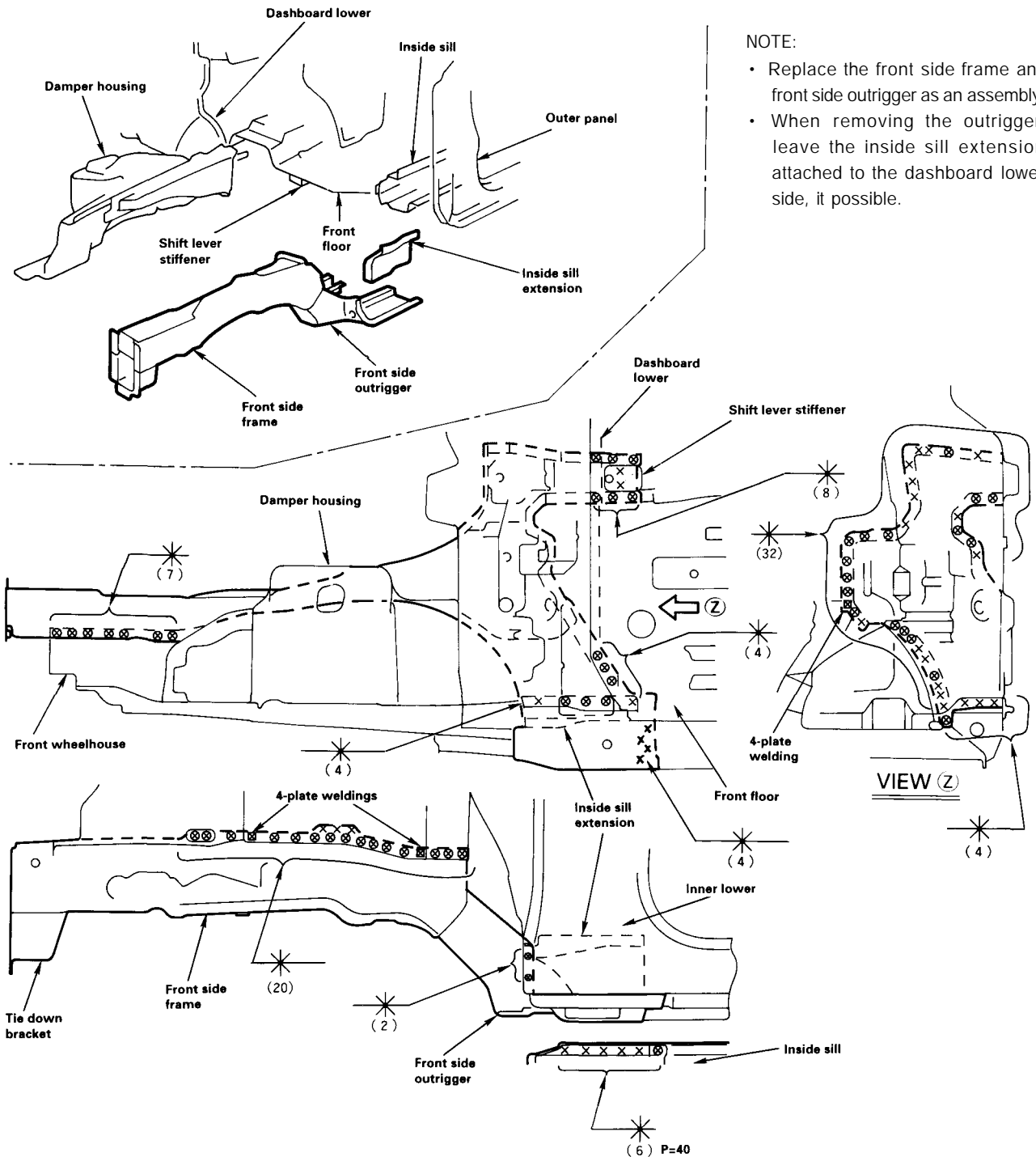

# Front Side Frame

## Replacement

1. Remove the related parts.
  - Front suspension related parts
  - Brake hoses and pipes
  - Engine compartment electrical components
  - Fittings in passenger compartment, etc.
  - Steering gearbox.
2. Remove the rear beam.

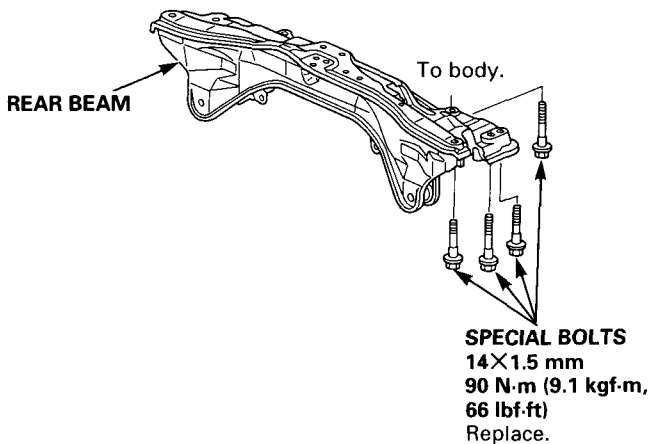
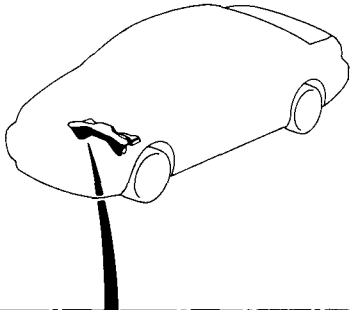

NOTE: With the front bulkhead removed.

3. Roughly pull out and straighten the damaged area.
    - Attach the car to the frame straightener by tightening the underbody clamps located at the horizontal pinch welds.
- NOTE: Refer to the Civic Service Manual for safety satand location points.
- Before cutting off the damaged sections, pull them out so that they are restored to the original shape.
  - Cutting off the front side frame before roughly pulling out the damage makes repair of the related front floor, lower dashboard, and other related parts difficult.

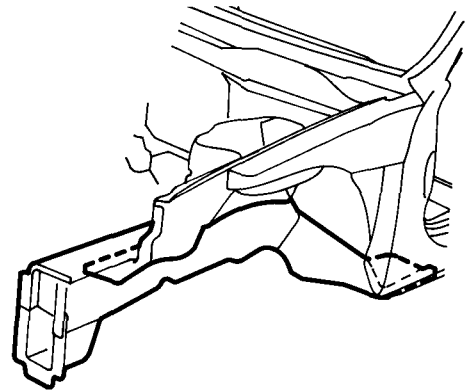

4. Peel off the undercoat.

Heat the undercoat at the weld areas of the lower dashboard, front floor and side sill with a gas torch and peel off the undercoat with a metal spatula.

**CAUTION:** Be careful not to burn the fittings inside the passenger compartment and dashboard insulator when heating.

5. Remove the front side frame.

NOTE: It's not necessary to separate the front wheelhouse from the front side frame if the wheelhouse/damper housing is to be replaced also.

- Center punch around the spot weld imprints on the wheelhouse and damper housing.
- Using a spot cutter, drill holes in the spot welded areas.
- Peel off the welding flange using the chisel.

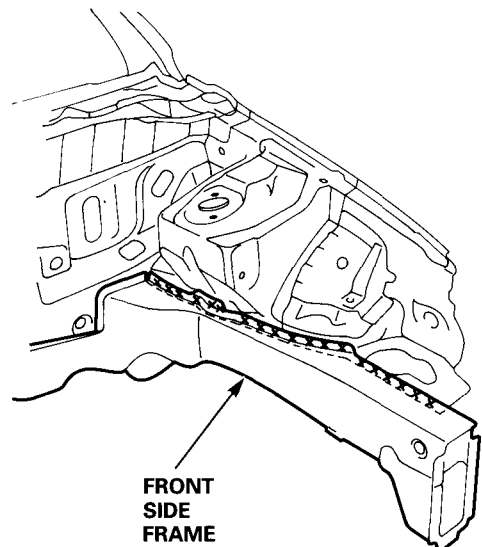

- Leave the inside sill extension attached to the dashboard lower side.

NOTE: When drilling holes, be careful not to drill down to the inside sill extension.

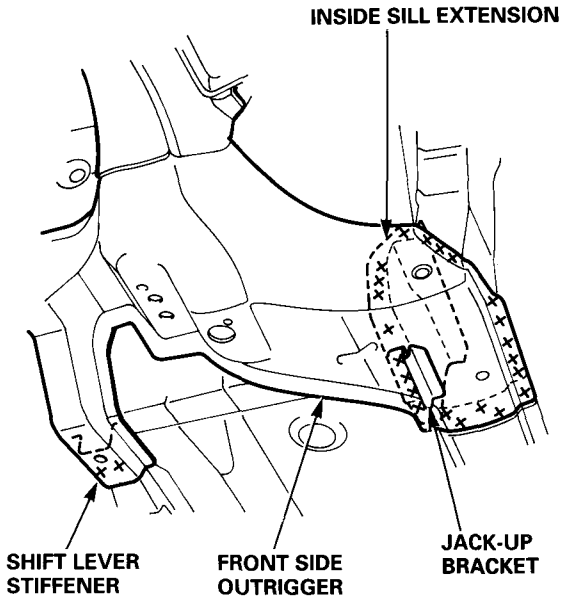

- Center punch around the spot weld imprints on the front side frame and front side outrigger from inside the passenger compartment.
- Drill holes in the spot welded area with a 5 mm (0.2 in) drill.

NOTE: Drill holes completely through the parts since the replacement front side frame and front side outrigger will be welded by MIG welding.

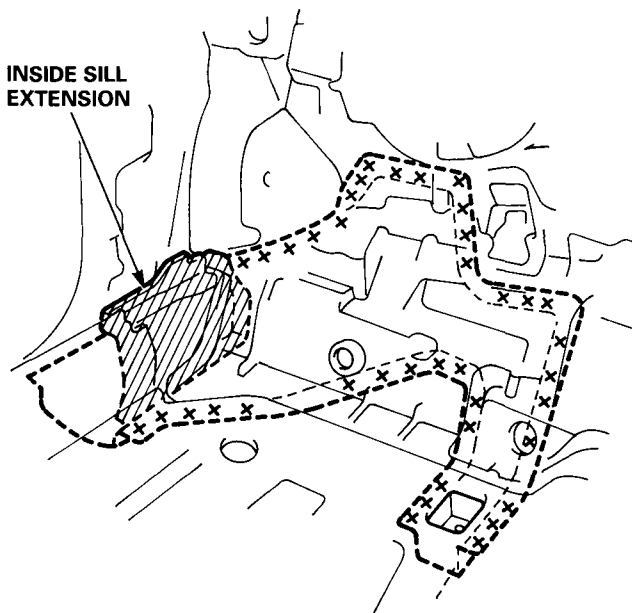

- Check the inside sill extension for position and damage.

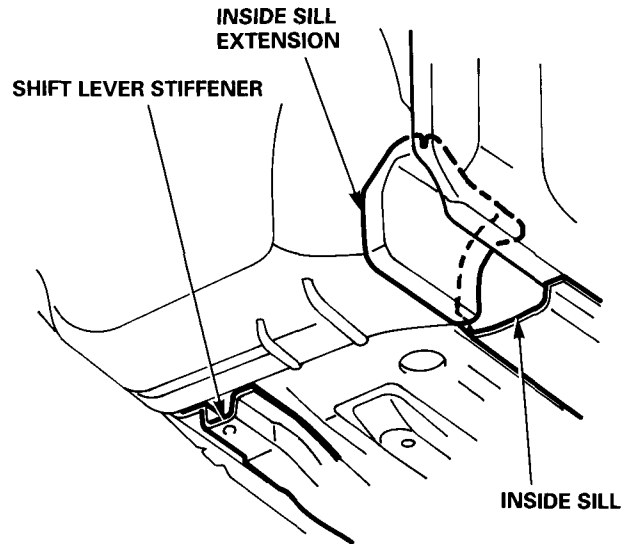

6. Mold the related parts.

- Reshape the front wheelhouse and damper housing lower dashboard-to-front floor joint using a hammer and dolly.
- Fill all drilled holes by MIG or gas welding.

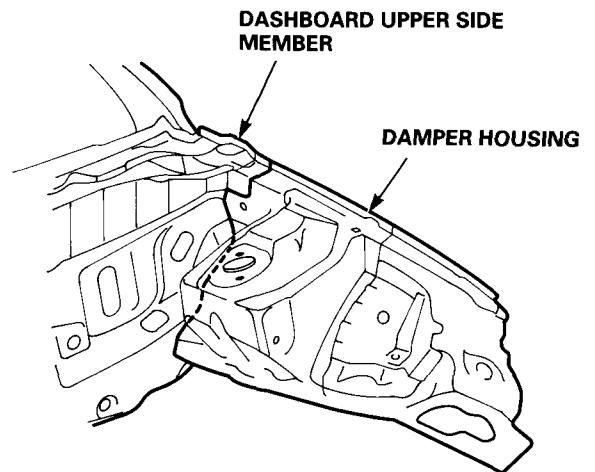

(cont'd)

# Front Side Frame Replacement (cont'd)

7. Remove the inside sill extension from the new front side outrigger.
  - Drill holes with a spot cutter from the front side outrigger side.
  - Keep the holes to a minimum since they will be used as weld holes for MIG welding of the new part.

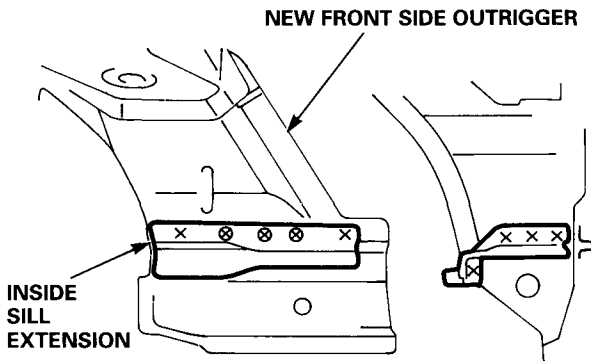

8. Set the new front side frame.
  - Remove the undercoat from the both sides of the welding section, and expose the steel plate using a disc sander.

**⚠ WARNING** To prevent eye injury, wear goggles or safety glasses whenever sanding, cutting or grinding.

NOTE: Apply the spot sealer to the welding surface when spot welding.

- Place a jack under the front side frame end and support it, and measure the positions for temporary attachment.

NOTE: Use of a positioning jig is recommended (see page 1-8).

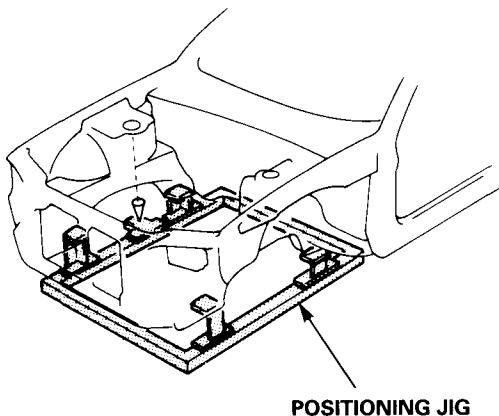

- Clamp the front bulkhead and front wheelhouse/damper housing with squill vises and vise-grips.
- Measure the front compartment diagonally.
- Spot weld several points in the clamped sections, and temporarily attach the front side frame.

**⚠ WARNING** To prevent eye injury and burns when welding, wear an approved welding helmet, gloves and safety shoes.

- Check the body dimensions (see section 6).
- Install the rear beam, and check the front side frame position.

9. Perform the main welding.
  - Make 20% to 30% more spot welds than there were holes drilled.
  - Weld as much as possible with the jig still mounted.
  - Weld the front side frame, wheelhouse, damper housing and bulkhead.

**⚠ WARNING** To prevent eye injury and burns when welding, wear an approved welding helmet, gloves and safety shoes.

- Ⓐ and Ⓑ, make 5 mm (0.2 in) holes in the MIG weld holes with the outrigger, and plug weld the inside sill and shift lever stiffener with a MIG welder.

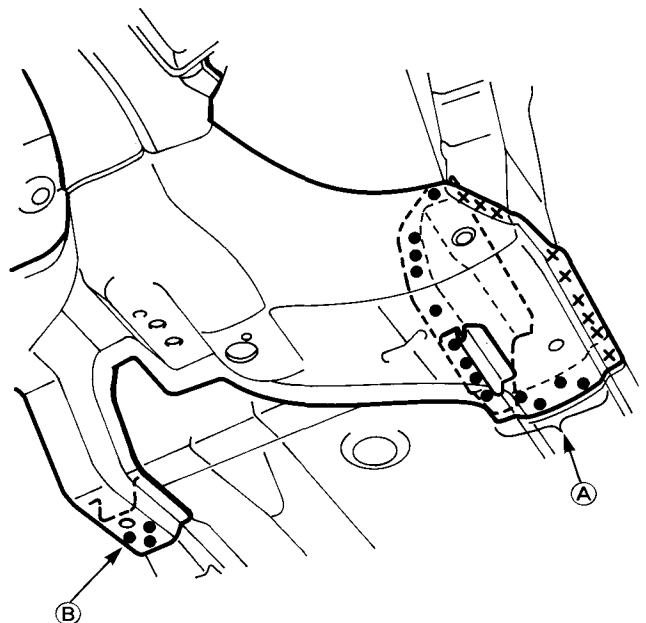



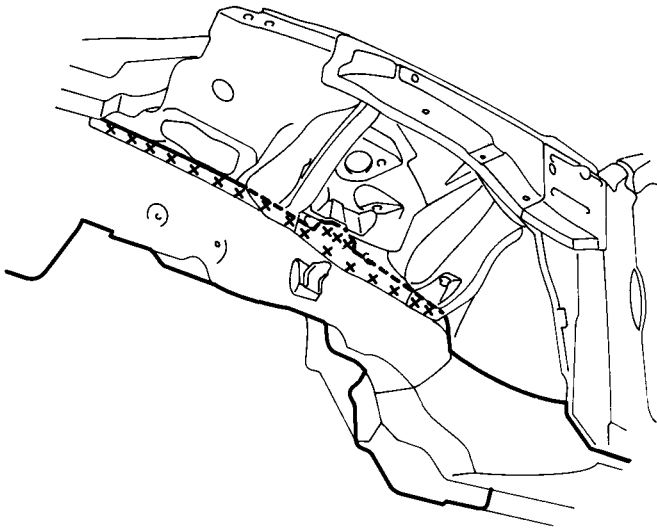

- From the passenger compartment side, plug weld the holed areas of the lower dashboard and front floor with a MIG welder.

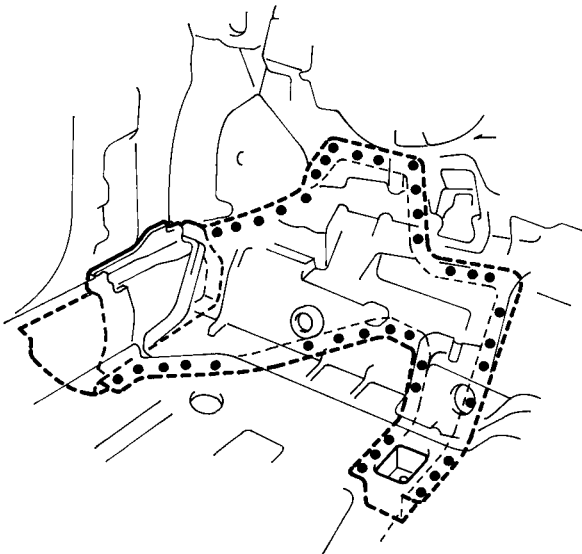

10. Finish the welds.

Use a hammer and dolly to even out the damper housing, wheelhouse, lower dashboard, front bulkhead and side sill flanges for a close fit with the surface of the front side frame.

11. Apply the sealer (see [section 5](#)).

Apply sealer to the mating surfaces of the lower dashboard, etc.

12. Apply the paint.

See Paint Repair section.

**⚠ WARNING**

- **Ventilate when spraying paint.** Most paint contains substances that are harmful if inhaled or swallowed. Read the paint label before opening the paint container.
- **Avoid contact with skin.** Wear an approved respirator, gloves, eye protection and appropriate clothing when painting.
- **Paint is flammable.** Store it in a safe place, and keep it away from sparks, flames or cigarettes.

13. Apply the undercoat.

Undercoat the front floor, and apply anti-rust agent to the inside of the welding section of the side sill, front side frame, etc (see [section 7](#)).

14. Install the related parts.

Install in the reverse order in which they were removed.

15. Inspect, check and adjust.

- Measure the front wheel alignment.
- Inspect the brake system.
- Adjust the headlight aim.

# Front Side Outrigger

## Description

The front side outriggers connect the front side frames to the body and are vital to the rigidity of the entire body frame. Pay particular attention when welding the front side outriggers from beneath the front floor and side sill.

## Mass Production Body Welding Diagram

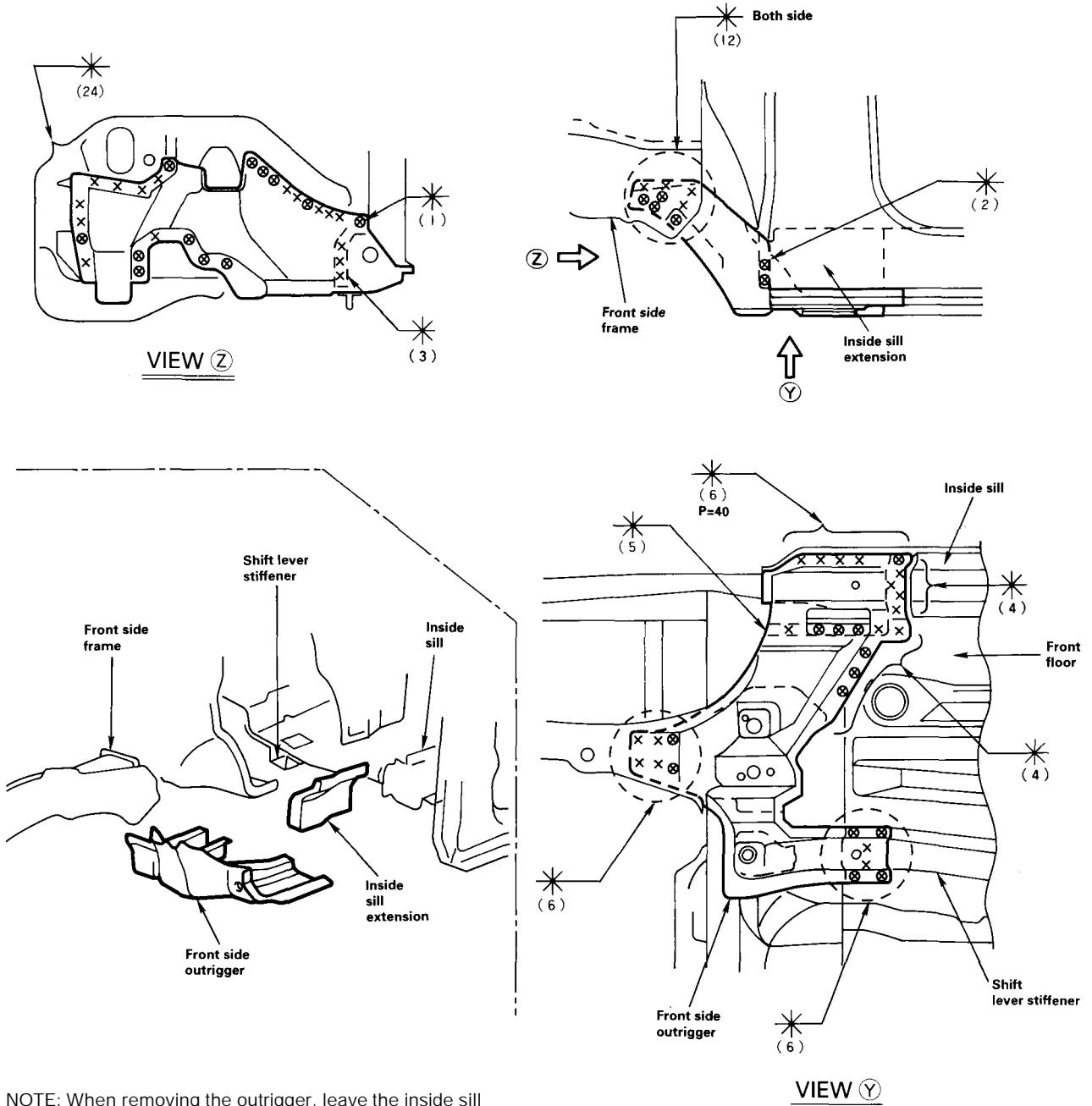

NOTE: When removing the outrigger, leave the inside sill extension attached to the dashboard lower, if possible.

# Replacement

1. Remove the related parts.
  - Front seat
  - Carpet
  - Refer to the front side frame (see page 4-16).
2. Pull out and straighten the damaged area.
  - The front side outrigger receives impact through the front side frame or side sill. Such impact generally requires replacement of all these parts.
  - Before cutting off the front side outrigger or side sill, pull out the damaged area with the frame straightener and correct the related parts such as the front floor and dashboard. Check the clearance and level differences of the front doors.
  - Jack up the body and place safety stands at the four designated places of the side sills. If necessary, place safety stands at the rear of the frame.
3. Peel off the undercoat.
 

Heat the undercoat at the weld areas of the front side outrigger and side frame with a gas torch and peel off the undercoat with a metal spatula.

**CAUTION:** Be careful not to burn the fittings inside the passenger compartment and dashboard insulator when heating.

4. Remove the front side outrigger.
  - Center punch around the spot weld imprints on the front side outrigger from inside the passenger compartment.
  - Drill holes in the spot welded areas with a 5 mm (0.2 in) drill.

**NOTE:** Drill holes through the parts completely since the replacement front side outrigger will be welded by MIG welding.

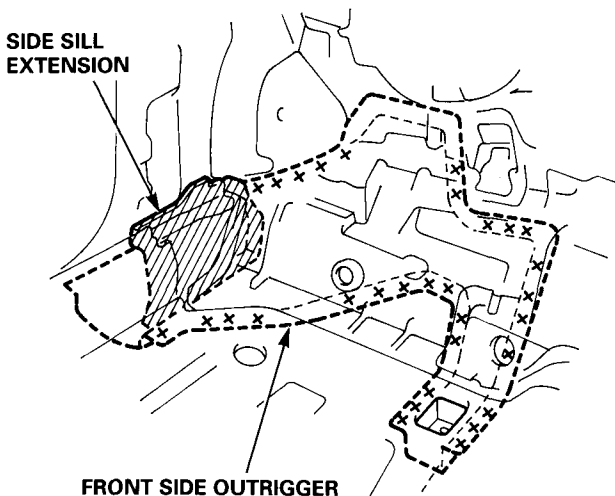

- Leave the inside sill extension attached to the dashboard lower side.

**NOTE:** When drilling holes, be careful not to drill down to the inside sill extension.

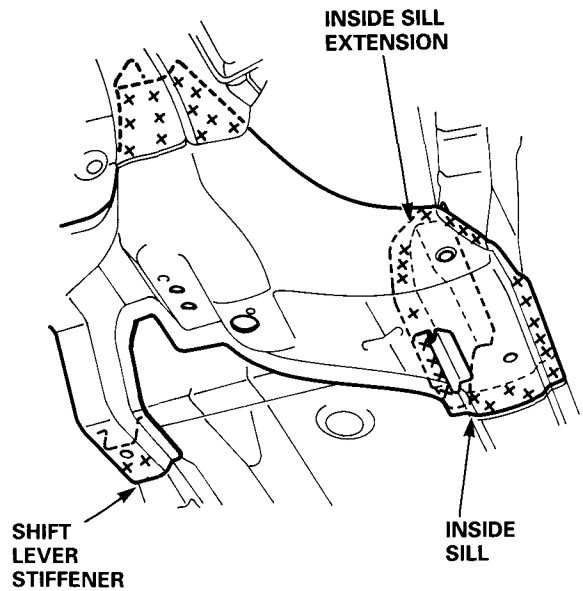

- Check the inside sill extension and rear of the side frame for position and damage.
- Replace the front side frame if necessary.

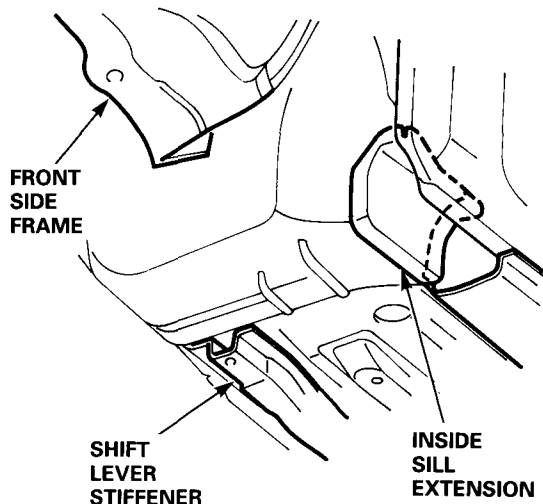

- Level off and finish the burrs of the pried off spot welds with a disc sander.

**⚠ WARNING** To prevent eye injury, wear goggles or safety glasses whenever sanding, cutting or grinding.

(cont'd)

# Front Side Outrigger

## Replacement (cont'd)

5. Mold the related parts.  
Reshape the lower dashboard, front side frame, front floor, inside sill and side sill inner joint using a hammer shift lever stiffener with a MIG welder.
6. Remove the inside sill extension from the new front side outrigger (see page 4-18).
7. Set the new front side outrigger.
  - Remove the undercoat from both sides of the areas to be spot welded with a sander to expose the steel plate.
  - Clamp the weld flanges with the side sill using the vise-grip pliers. Set the front side outrigger on the side frame using a jack.
  - Drill 3 mm (0.12 in) holes, and screw 5 mm self-tapping screws into the drilled holes at the areas where the front side outrigger does not fit closely.

### NEW FRONT SIDE OUTRIGGER

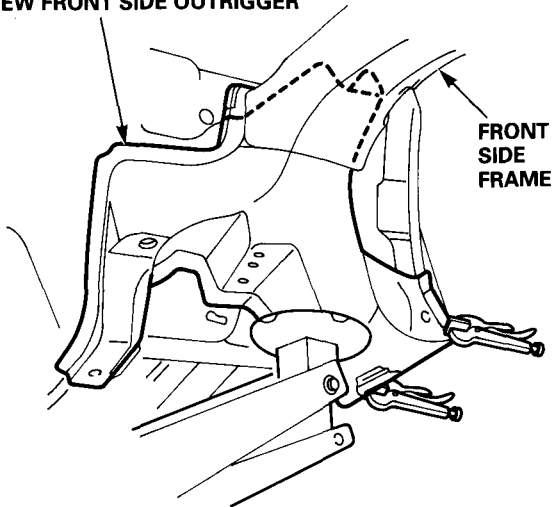

- Check the body dimensions (see section 6).

8. Tack weld the new front side outrigger.

**⚠ WARNING** To prevent eye injury and burns when welding, wear an approved welding helmet, gloves and safety shoes.

- Install the rear beam, and check the front side outrigger position.

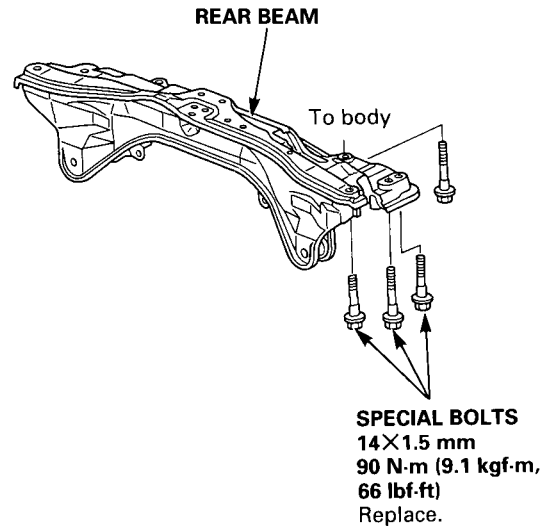

9. Perform the main welding.

**⚠ WARNING** To prevent eye injury and burns when welding, wear an approved welding helmet, gloves and safety shoes.

- From the passenger compartment side, weld the holes in the lower dashboard, front floor and floor frame with a MIG welder.
- Make 20% to 30% more spot welds than there were holes drilled.

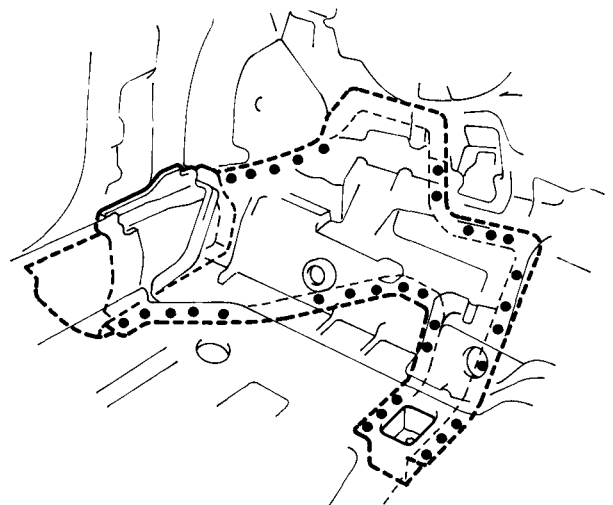

- Weld the front side frame and front side outrigger using MIG welds.
- **(A)** and **(B)**, make 5 mm (0.2 in) holes in MIG weld holes with the outrigger, and plug weld the inside sill and shift lever stiffener with a MIG welder.

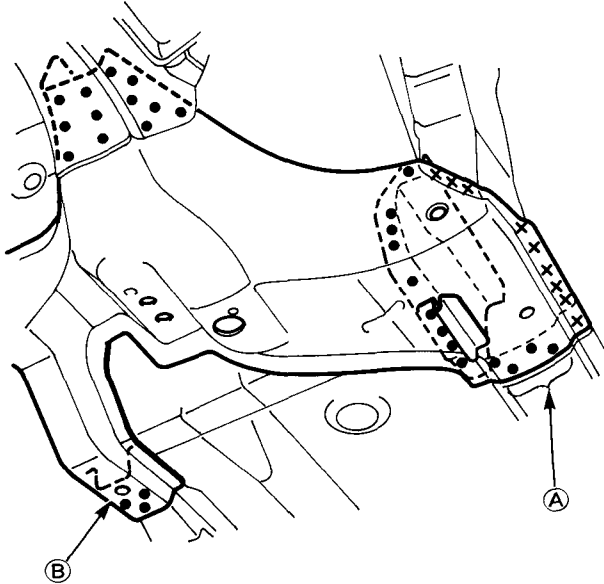

10. Apply the sealer (see [section 5](#)).  
Apply sealer to the mating surface of the lower dashboard and front floor.
11. Apply the paint.  
See Paint Repair section.

**⚠ WARNING**

- **Ventilate when spraying paint.** Most paint contains substances that are harmful if inhaled or swallowed. Read the paint label before opening the paint container.
  - **Avoid contact with skin.** Wear an approved respirator, gloves, eye protection and appropriate clothing when painting.
  - **Paint is flammable.** Store it in a safe place, and keep it away from sparks, flames or cigarettes.
12. Apply the undercoat.  
Under coat the front floor, etc, and apply anti-rust agent to the inside of the front side outrigger and side sill (see [section 7](#)).

# Front Pillar (Outer Panel)

## Description

The front pillar is connected to the roof, the windshield, the door hinges, and the side sills and is a highly important support. Connection of the front pillar determines the position of the windshield and the front door. Align the front fender, the door, and the windshield while the front pillar is loosely mounted, and check the clearances and level differences.

## Mass Production Body Welding Diagram

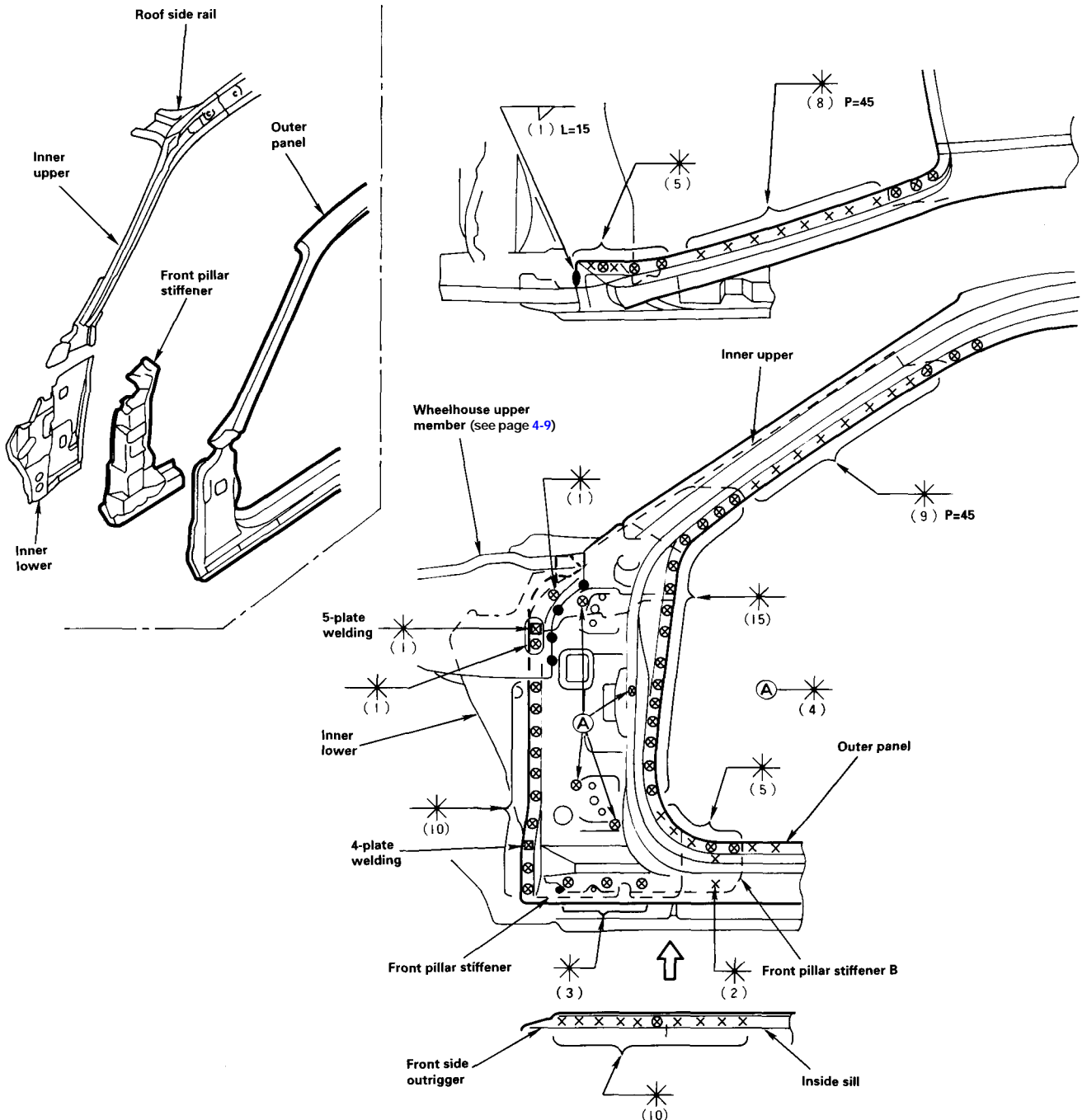

# Replacement

1. Remove the related parts:

- Hood
- Front fender
- Front door
- Windshield
- Front side trim
- Steering hanger pipe
- Side cowl lining
- Dashboard
- Front pillar trim
- Wire harness, etc.
- Steering column

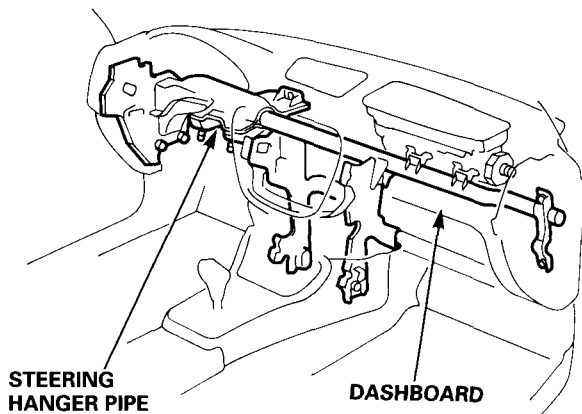

NOTE: Make sure that the right and left pillars are parallel with the windshield surface. Check the door for proper opening and closing.

2. Pull out and straighten the damaged area.

- Pull out the damaged area with the frame straightener before cutting off the front pillar extension and front pillar.

NOTE: Pull out until the pillar is lined up with the surface of the windshield.

- With the pillar pulled out, pull out and straighten the related lower dashboard and floor section.
- After pulling, check the inner pillar position using the body dimensional drawings (see [section 6](#)).

3. Remove the wheelhouse upper member.

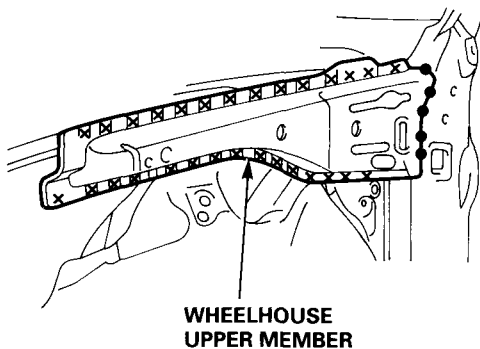

4. Cut off the front pillar.

- Cut off the front pillar along the bold line shown in the figure to the right with a gas cutter.
- Use a handsaw to cut the windshield and side sill areas.

NOTE: Be careful not to cut the inner section.

- Center punch around the spot weld imprints.
- Drill holes using a spot cutter.
- Chisel off the weld flanges.
- Finish the burrs at the drilled areas with a disc sander.

**▲ WARNING** To prevent eye injury, wear goggles or safety glasses whenever sanding, cutting or grinding.

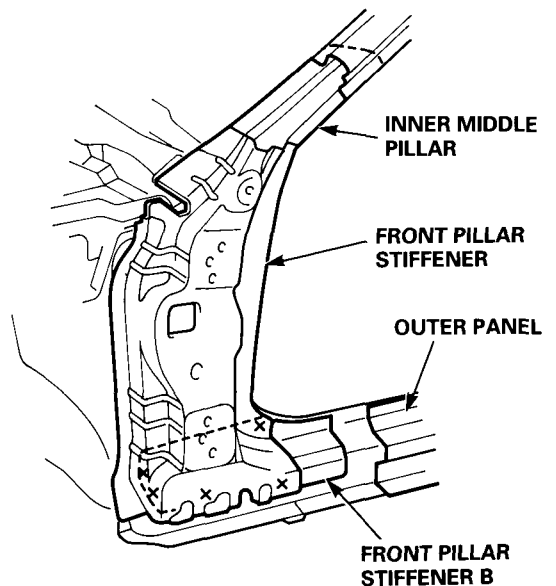
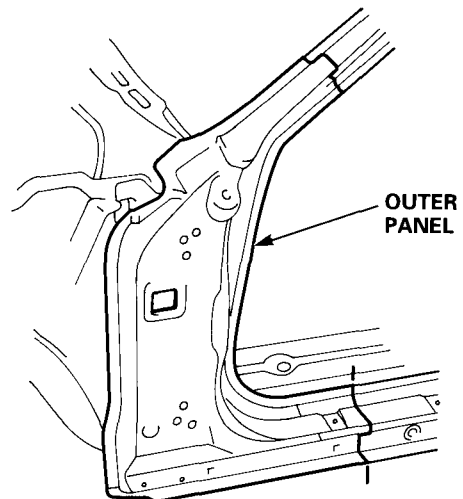

(cont'd)

# Front Pillar (Outer Panel)

## Replacement (cont'd)

5. Mold the related parts.  
Fill any holes by MIG or gas welding, and even out with a hammer and dolly.

**⚠ WARNING** To prevent eye injury and burns when welding, wear an approved welding helmet, gloves and safety shoes.

6. Set the repair part
  - Align the repair part with the top cut section, then cut it with a handsaw.

NOTE: Cut the side sill joint with a handsaw leaving an overlap of 30 mm (1.2 in).

- Remove the undercoat from both sides of the areas to be spot welded with a sander to expose the steel plate.

NOTE: Apply the spot sealer to the welding surface when spot welding.

- Clamp with vise-grips as shown.
- Check the body dimensions (see [section 6](#)).

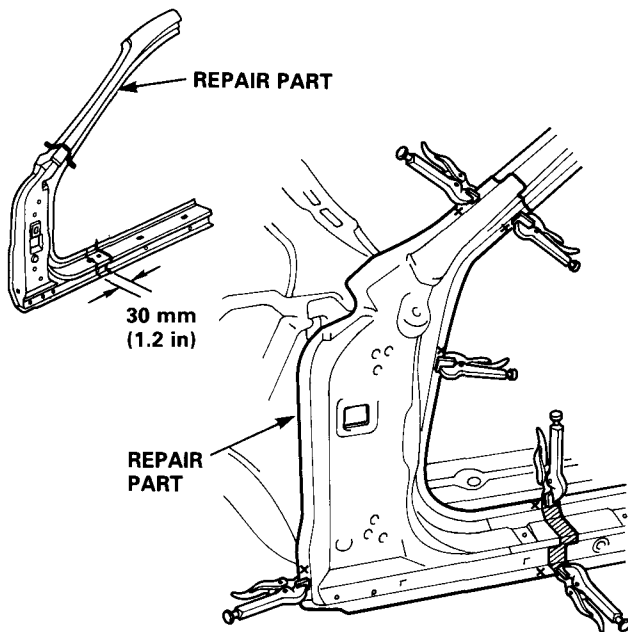

7. Tack welds the clamped sections.

**⚠ WARNING** To prevent eye injury and burns when welding, wear an approved welding helmet, gloves and safety shoes.

8. Temporarily mount the door and front fender.
  - Remove the vise-grips, then mount the door.
  - Check the clearance and level differences of the door and fender.
9. Perform main welding.
  - Weld the front pillar and side sill outer joints with a MIG welder.
  - Make 20% to 30% more spot welds than there were holes drilled.

**⚠ WARNING** To prevent eye injury and burns when welding, wear an approved welding helmet, gloves and safety shoes.

- Make 5 mm (0.2 in) holes in the MIG weld holes with the repair part, and weld the front pillar stiffener and dashboard upper side member with a MIG welder.

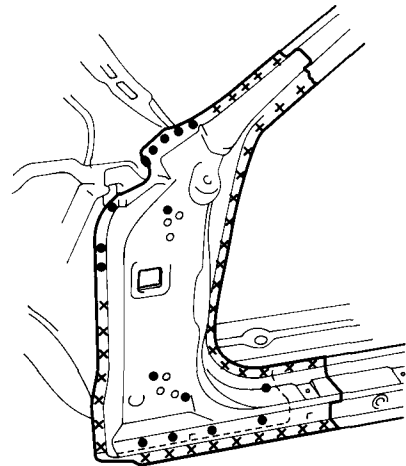

- Weld the wheelhouse upper member.

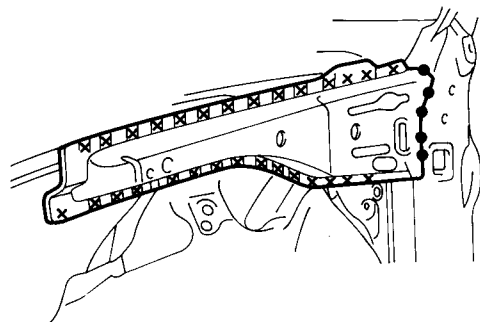



10. Finish the welding areas.

- Finish grind the finishing allowance with a disc sander until it is smooth.

**⚠ WARNING** To prevent eye injury, wear goggles or safety glasses whenever sanding, cutting or grinding.

- Smooth the flanged section of the door opening with a hammer and dolly.

11. Apply the sealer (see [section 5](#)).

12. Apply the paint.

See Paint Repair section.

**⚠ WARNING**

- **Ventilate when spraying paint.** Most paint contains substances that are harmful if inhaled or swallowed. Read the paint label before opening the paint container.
- **Avoid contact with skin.** Wear an approved respirator, gloves, eye protection and appropriate clothing when painting.
- **Paint is flammable.** Store it in a safe place, and keep it away from sparks, flames or cigarettes.

13. Apply anti-rust agent to the inside of the front pillar, wheelhouse upper member and side sill (see [section 7](#)).

14. Install the related parts.

- Install in the reverse order of removal.
- Check the door for proper installation and level difference from the fenders.

15. Clean and check.

- After installing the dashboard, check the lights and gauges for proper operation.
- Clean the passenger compartment and check for water leaks.

# Windshield Lower

## Description

Impact damage to the windshield lower area may spread to the back of the panel and wiper mounting area, calling for replacement of the affected skins.

## Mass Production Body Welding Diagram

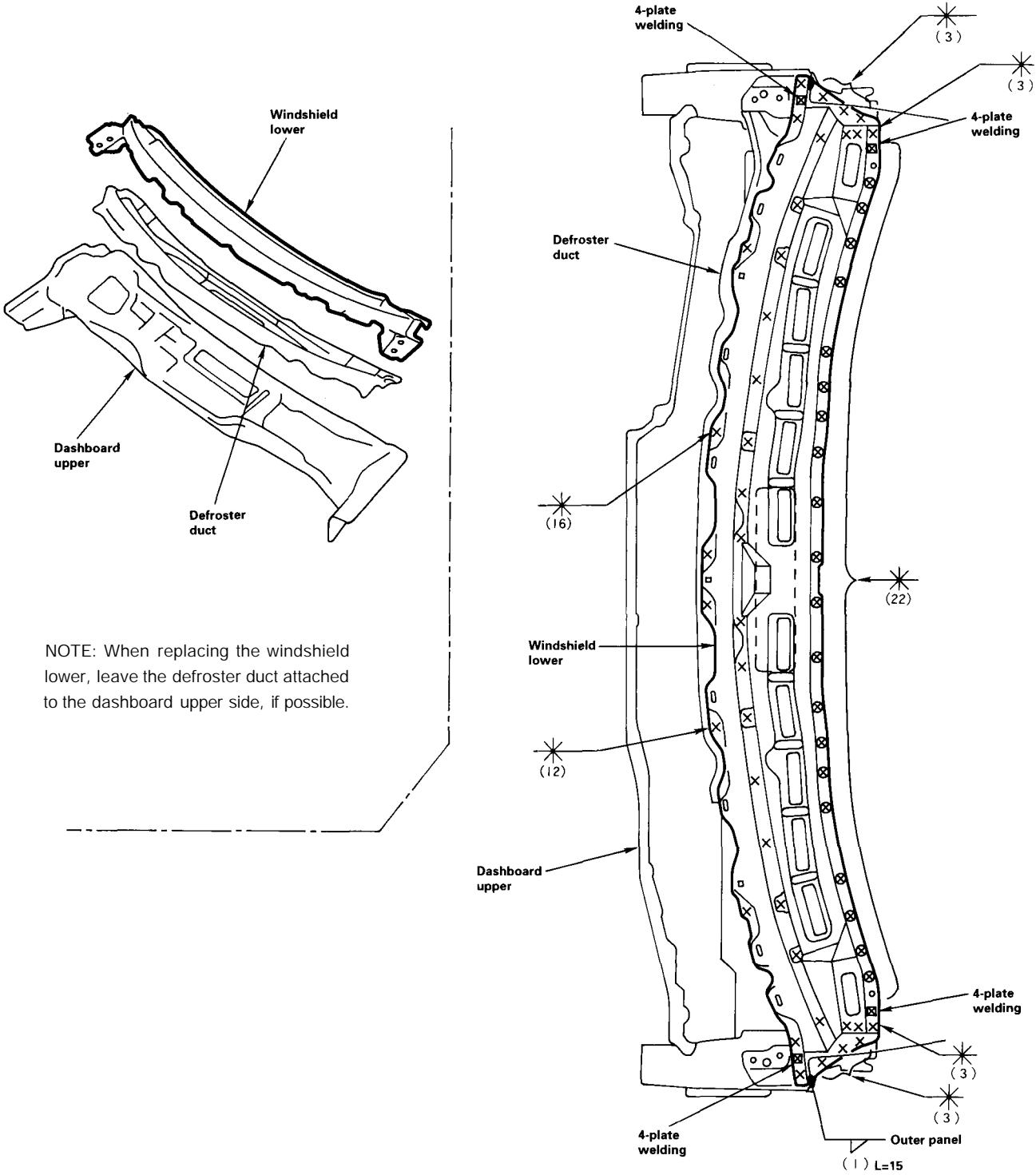

## Replacement

- Remove the related parts.
  - Wiper arm and motor
  - Windshield
  - Right and left front fenders
  - Right and left front door opening trims
  - Front pillar trim
  - Hood
  - Wire harnesses and electrical accessories
  - Steering column
  - Dashboard, etc
- Cut the windshield lower and separate the welded flange.
  - Center punch around the spot weld imprints.
  - Drill holes with a spot cutter through the nuggets.
  - Peel off the welding flange using a chisel.
  - Level off and finish the burrs of the pried-off spot welds with a sander.

**⚠ WARNING** To prevent eye injury, wear goggles or safety glasses whenever sanding, cutting or grinding.

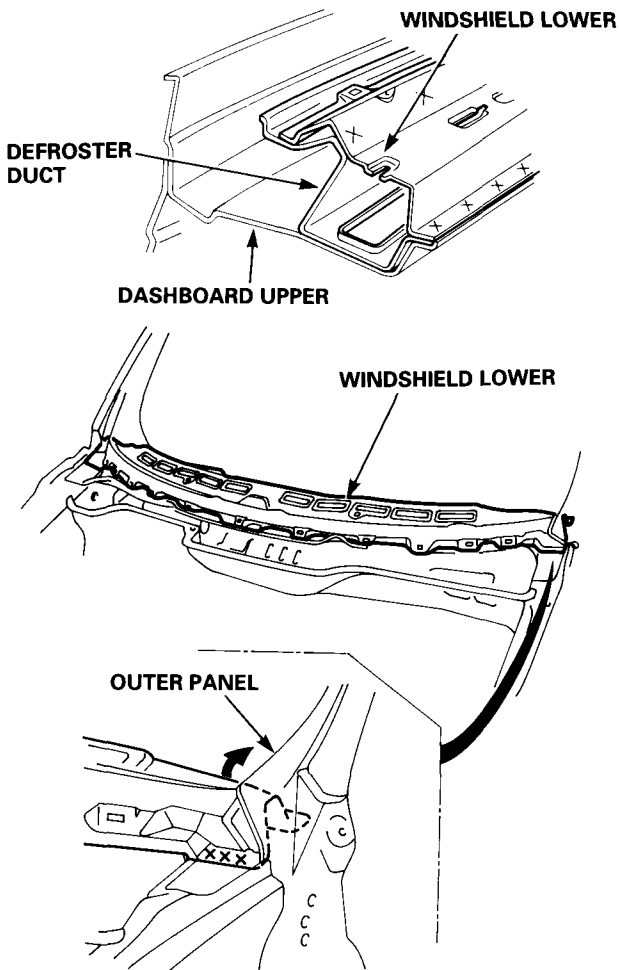

- Set the new windshield lower.
  - Apply an undercoat and body paint to the inside.

**⚠ WARNING**

- Ventilate when spraying paint.** Most paint contains substances that are harmful if inhaled or swallowed. Read the paint label before opening the paint container.
- Avoid contact with skin.** Wear an approved respirator, gloves, eye protection and appropriate clothing when painting.
- Paint is flammable.** Store it in a safe place, and keep it away from sparks, flames or cigarettes.
- Sand off the undercoat down to the metal from both flanges to be welded.
- Clamp the new windshield lower in place with vise-grips and squill vises.

NOTE: Apply the spot sealer to the welding surface when spot welding.

- Install the new windshield and check for proper installation and alignment.
- Tack weld the new windshield lower.

**⚠ WARNING**

To prevent eye injury and burns when welding, wear an approved welding helmet, gloves and safety shoes.

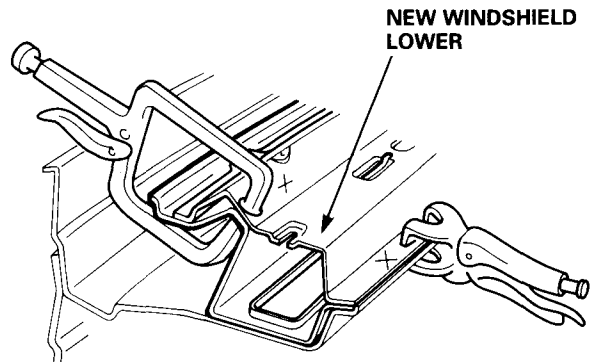

- Remove the vise-grips and install the fender and hood. Check for differences in level and clearance.
- Perform the main welding.
    - Make 20% to 30% more spot welds than there were holes drilled.

**⚠ WARNING**

To prevent eye injury and burns when welding, wear an approved welding helmet, gloves and safety shoes.

(cont'd)

# Windshield Lower Replacement(cont'd)

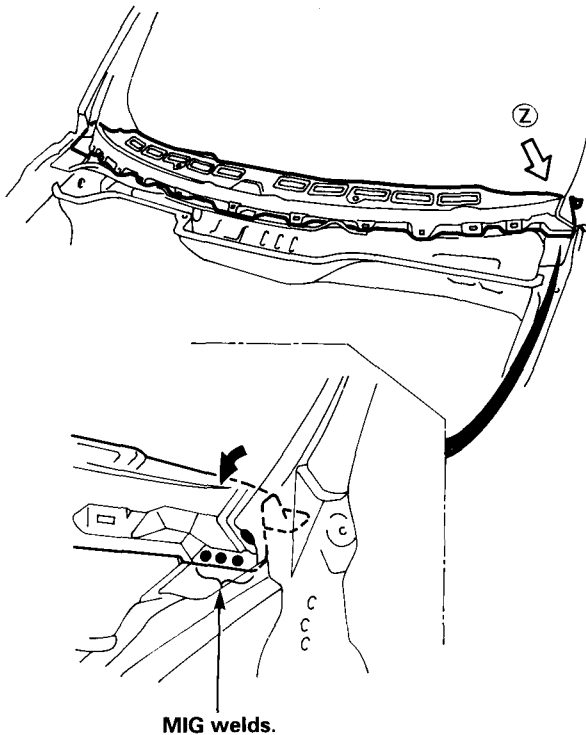
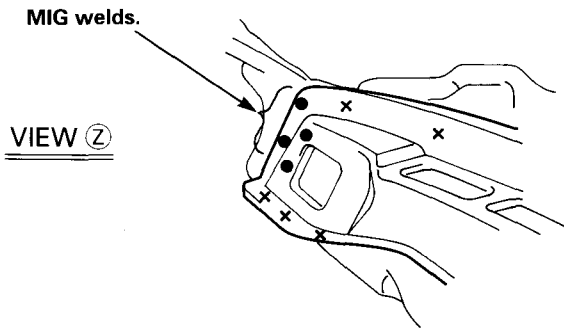

6. Finish the welding section.  
Smooth the mating surface with the windshield with a hammer and dolly.
7. Apply the sealer (see [section 5](#)).  
Apply sealer to the upper dashboard, pillars, etc.
8. Install the front fender and hood.  
Check the front fender and hood for differences in level and clearance.

9. Apply the paint.  
See Paint Repair section.

**⚠ WARNING**

- Ventilate when spraying paint. Most paint contains substances that are harmful if inhaled or swallowed. Read the paint label before opening the paint container.
- Avoid contact with skin. Wear an approved respirator, gloves, eye protection and appropriate clothing when painting.
- Paint is flammable. Store it in a safe place, and keep it away from sparks, flames or cigarettes.

10. Apply anti-rust agent to the inside of the windshield lower and dashboard upper (see [section 7](#)).
11. Install the related parts.  
Install in the reverse order of removal.

NOTE: Take care not damage the windshield and the paint finishes.

12. Inspect and clean.
  - Check the windshield for water leaks.
  - After installing the dashboard, check the lights, gauges, etc. for proper operation.
  - Clean the interior.

# Side Sill (Outer Panel)

## Description

The side sill should, depending on the degree of damage, be repaired as much as possible rather than replaced. (Repair by pulling out with a slide hammer with a pin and washer welded on.)

# Side Sill (Outer Panel)

## Mass Production Body Welding Diagram

4-Door:

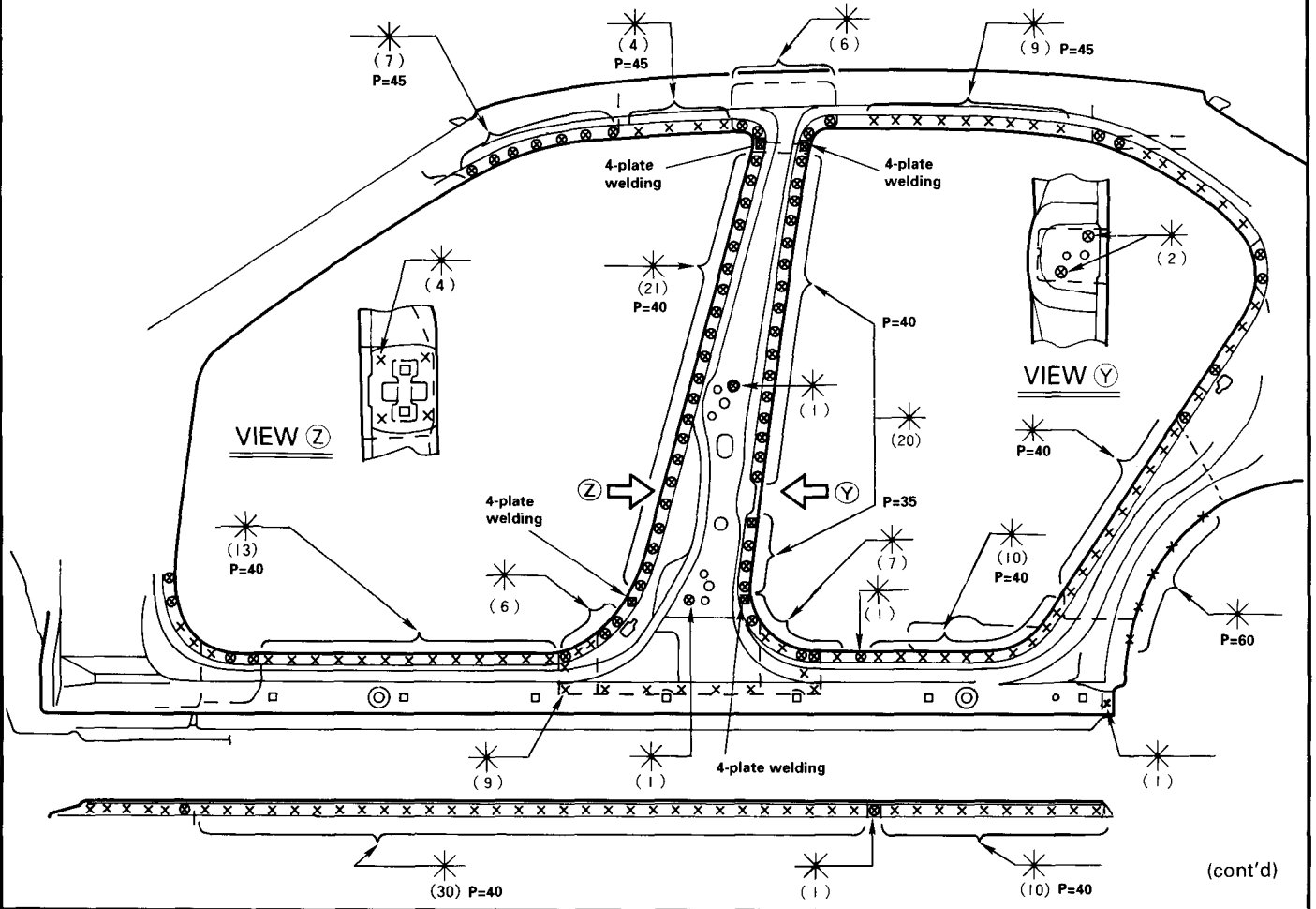
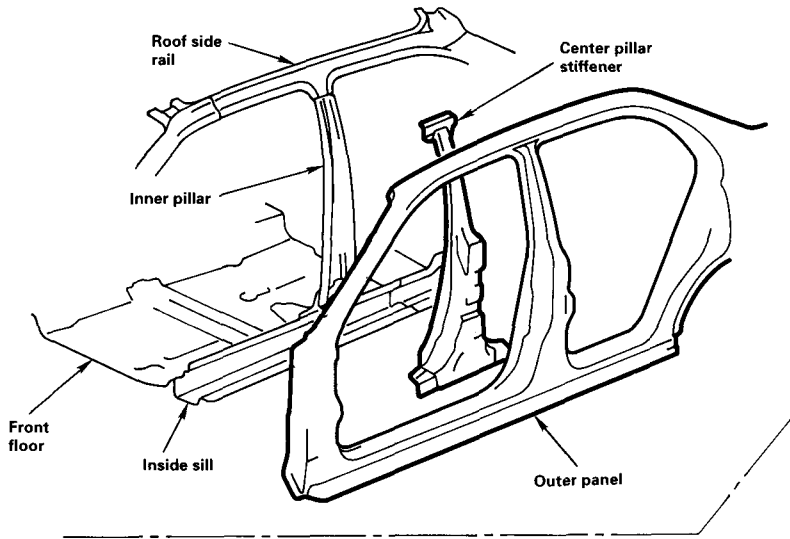

# Side Sill (Outer Panel)

## Mass Production Body Welding Diagram (cont'd)

3-Door/2-Door:

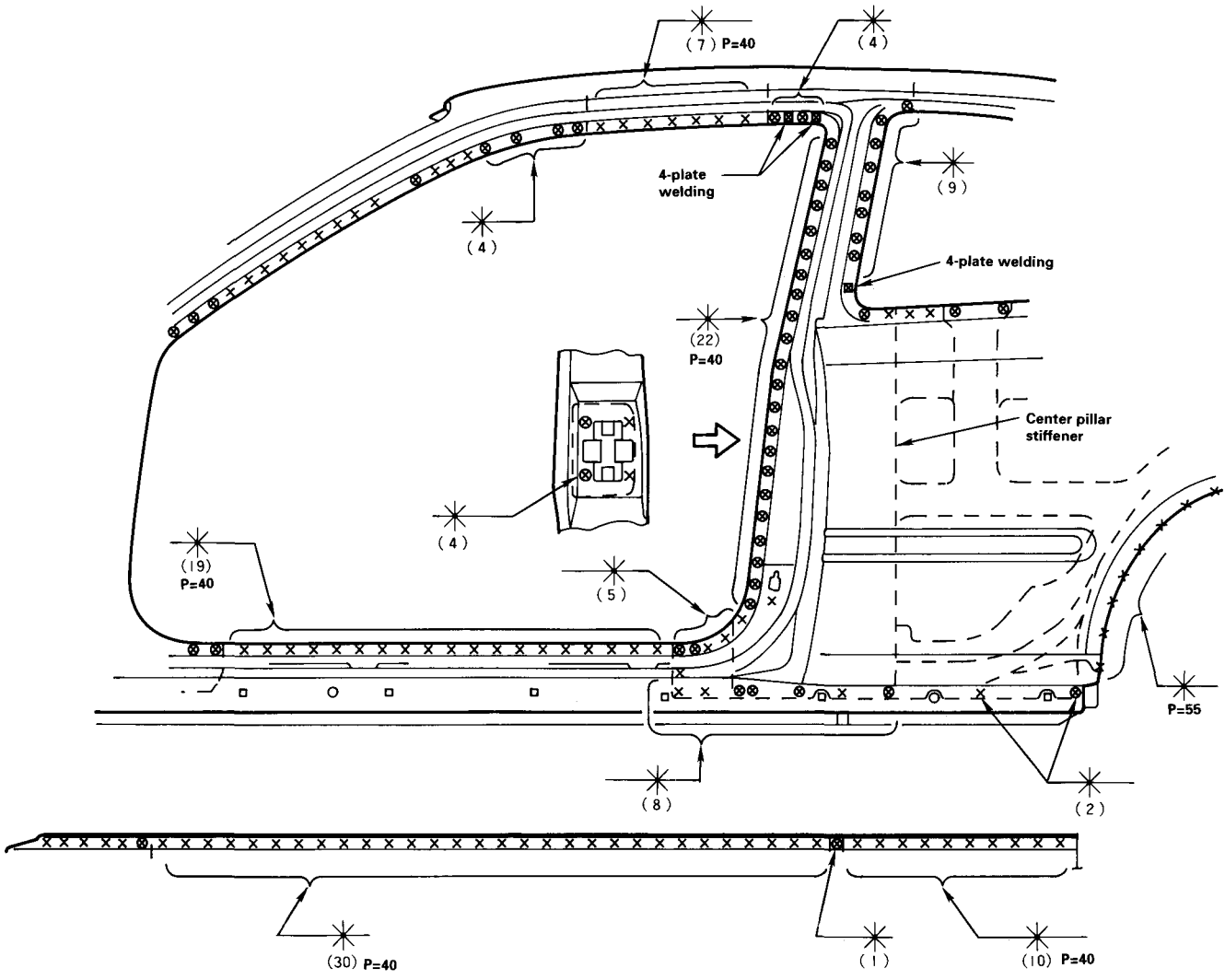
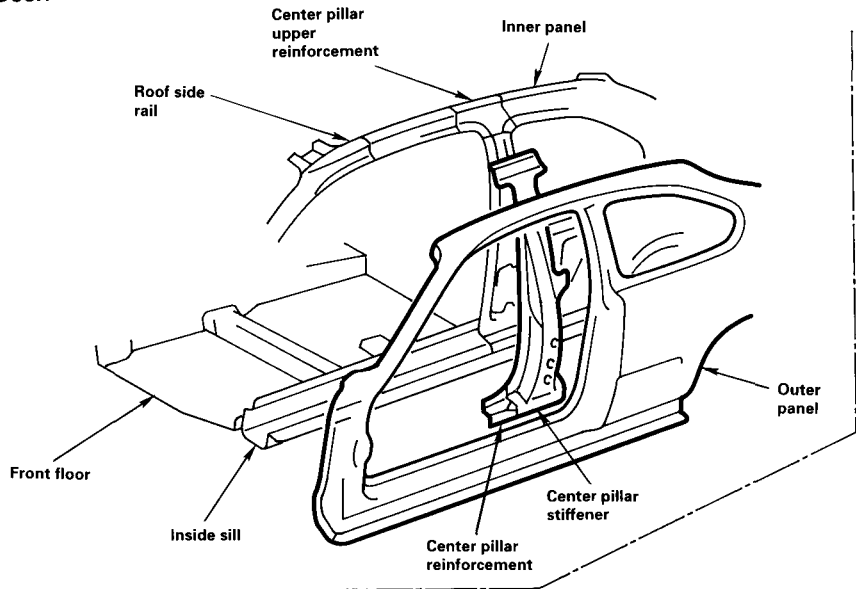

# Replacement.

1. Remove the related parts.
  - Front and rear doors  
(remove according to part damaged)
  - Side and center pillar trim
  - Carpet
  - Door switch
  - Seat belt
2. Pull out and straighten the damaged area.  
Damage may extend to the inner pillar, the inside sill and floor. Determine the extent of the damage first, so that the frame can be pulled out properly.
3. Cut and pry off the side sill.
  - Check the damage on the outer side sill, then cut the repair outer side sill so it will overlap by 30 mm (1.2 in) in the front and back.
  - Cut the side sill with a handsaw along the bold line shown in the figure to the right.

NOTE: Be careful not to cut the inside sill. This could result in extensive repair.

### 4-Door:

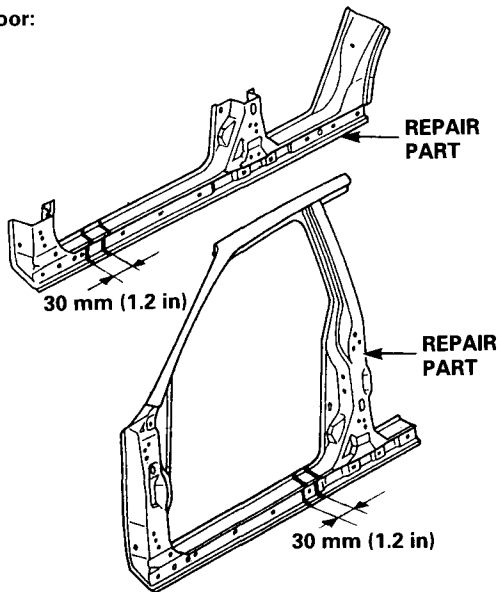

### 3-Door/2-Door:

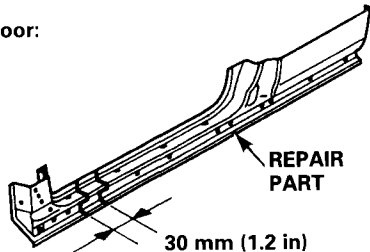

- If the damage involves part of the center pillar, cut them as shown with a handsaw.
- Cut the side sill with a chisel leaving the weld flanges intact.
- Center punch around the spot weld imprints on the welded flange.
- Drill holes using the spot cutter.
- Pry off the welded flange with a chisel.

NOTE: Be careful not to let the holes penetrate down to the inner section.

### 4-Door:

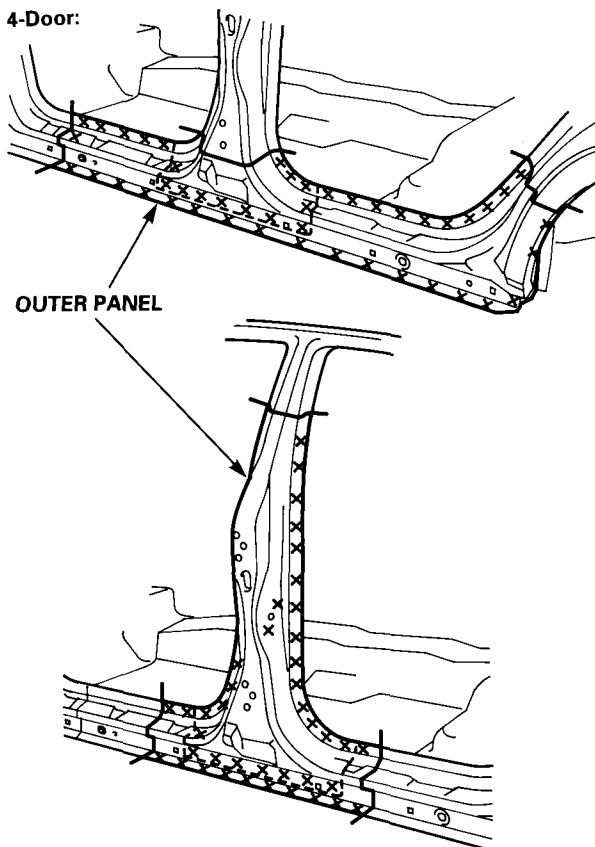

### 3-Door/2-Door:

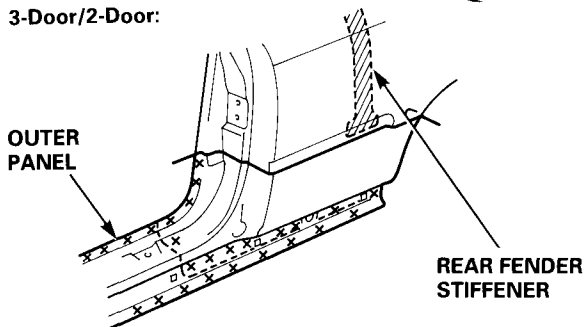

NOTE: Be careful not to cut the rear fender stiffener (2-door).

(cont'd)



# Side Sill (Outer Panel)

## Replacement (cont'd)

4. Mold the related parts.
  - Fill any holed areas by MIG or gas welding.

**⚠ WARNING** To prevent eye injury and burns when welding, wear an approved welding helmet, gloves and safety shoes.

- Level and finish burrs at welded areas with a disc sander, then even them out with a hammer and dolly.
- Sand off the undercoat from both sides of the flange to be welded.

4-Door:

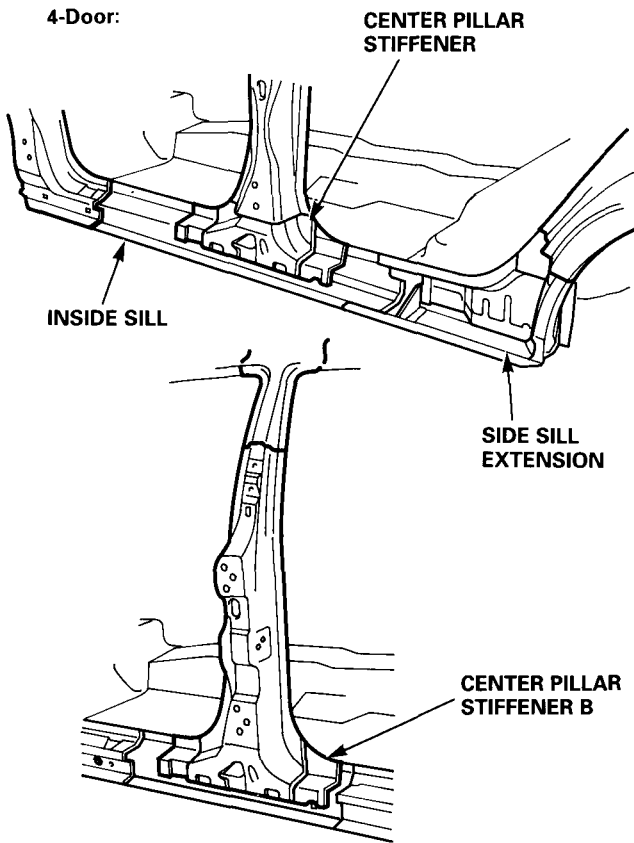

3-Door/2-Door:

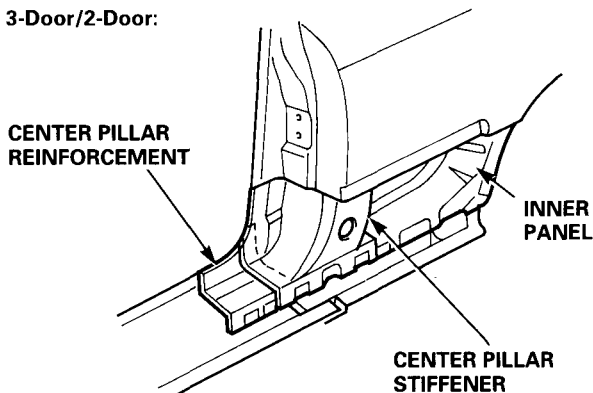

5. Set the repair part.
  - Sand off the undercoat from both sides of the welded flange on the repair part.
  - Clamp the repair part in place with vise-grips.

NOTE: Apply the spot sealer to the welding surface when spot welding.

- Check the body dimensions (see [section 6](#)).

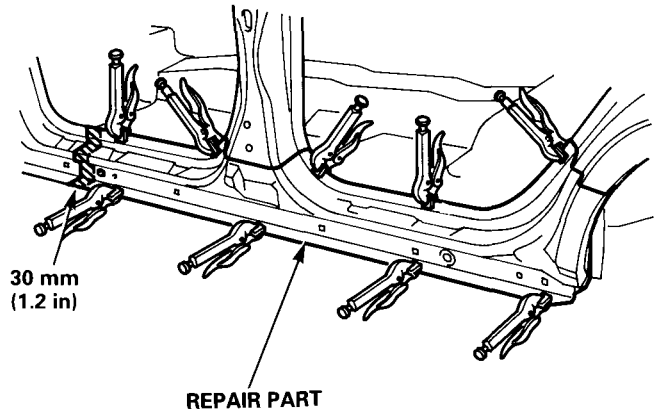

6. Tack weld the repair part.

**⚠ WARNING** To prevent eye injury and burns when welding, wear an approved welding helmet, gloves and safety shoes.

- Remove the vise-grips and install the fender and doors. Check for differences in level and clearance.

7. Perform main welding.

**⚠ WARNING** To prevent eye injury and burns when welding, wear an approved welding helmet, gloves and safety shoes.

- Weld the side sill and center pillar joints with a MIG welder.
- Spot weld the side sill flanges.
- Make 20% to 30% more spot welds than there were holes drilled.
- Make 5 mm (0.2 in) holes in the MIG weld holes with the repair part, and weld the center pillar stiffener with a MIG welder.
- Level the weld beads at the front and rear with a disc sander. Hammer down the projections, then fill with solder or putty to finish it.

**4-Door:**

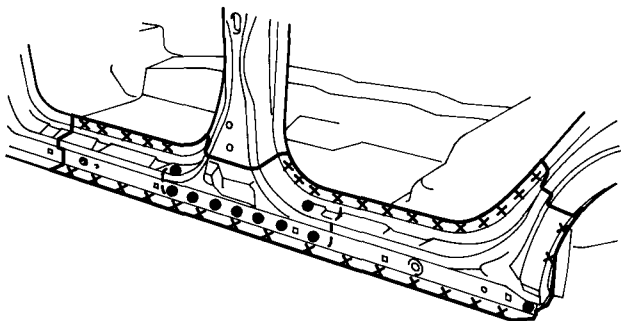

**3-Door/2-Door:**

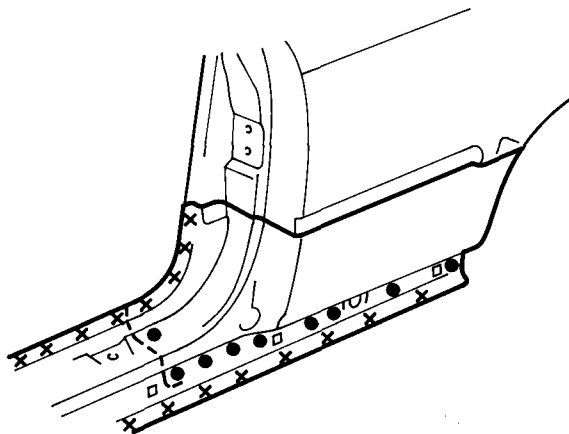

8. Apply the sealer.

Apply sealer to the mating surfaces of the floor and inside sill (see [section 5](#)).

9. Apply the paint.

See Paint Repair section.

**⚠ WARNING**

- **Ventilate when spraying paint.** Most paint contains substances that are harmful if inhaled or swallowed. Read the paint label before opening the paint container.
  - **Avoid contact with skin.** Wear an approved respirator, gloves, eye protection and appropriate clothing when painting.
  - **Paint is flammable.** Store it in a safe place, and keep it away from sparks, flames or cigarettes.
10. Apply the undercoat.  
Undercoat the front floor, and apply an anti-rust agent to the inside of the side sill and center pillar (see [section 7](#)).
11. Install the related parts.
- Install in the reverse order of removal.
  - Check the door for proper installation and level differences from the fenders.
12. Clean and check.  
Clean the passenger compartment and check for water leaks.

# Roof Panel

## Description

Deformation of the roof panel is highly noticeable in terms of the vehicle's outer appearance. Before replacing the roof rail, make sure that the body is horizontal. Before welding the roof panel, adjust the roof rail flanges so that they contact the roof panel.

## Mass Production Body Welding Diagram

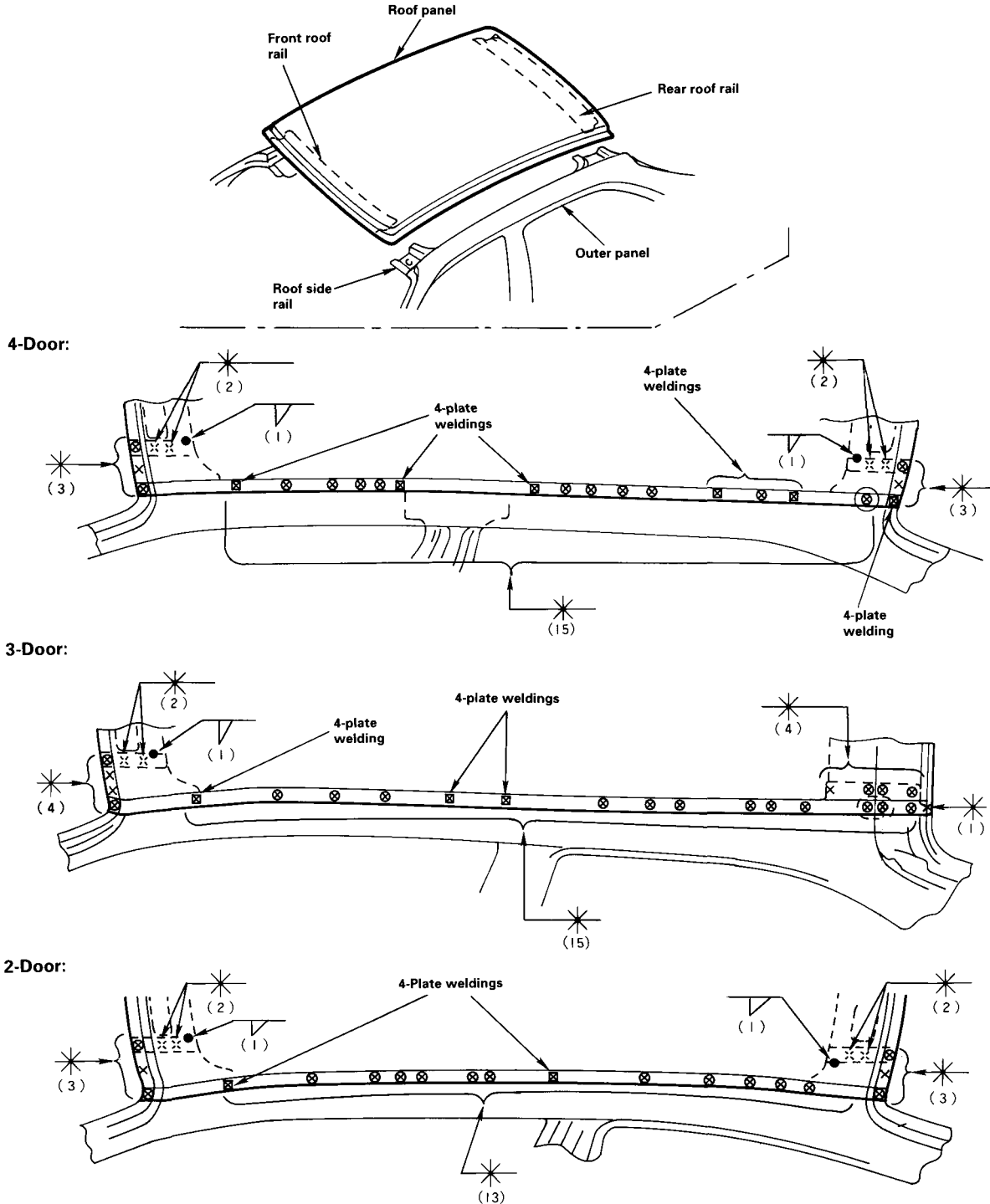

# Replacement

1. Remove the related parts.

- Windshield
- Rear window (4-door/2-door)
- Hatch (3-door)
- Sunvisor
- Ceiling lights
- Headliner
- Moonroof frame (for some types)

2. Pull out and straighten the damaged area to approximately the original shape.

NOTE: Check the inner front pillar and the inner center pillar for position and damage.

Cut the roof panel and pull out the pillars if necessary.

- Pull out the damaged area with the frame straightener before removing the roof panel.
- Attach the car to the frame straightener by tightening the underbody clamps located at the horizontal pinch welds.

3. Keep the body level.

NOTE: Refer to the Civic Service Manual for safety stand location points.

Jack-up the body at the front and back. Place safety stands at the four designated places of the side sills.

NOTE: Make sure that the right and left pillars are parallel with the windshield surface. Check the door for proper opening and closing.

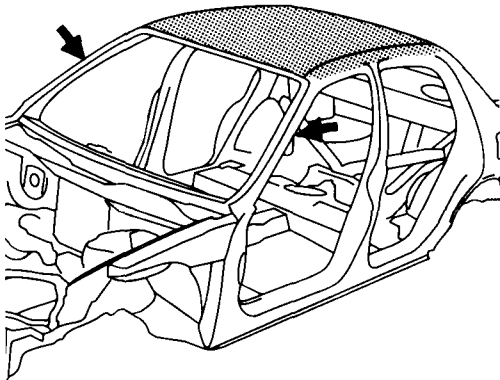

4. Cut off the shaded areas of the roof panel.

- Cut the roof rail weld flange with a handsaw at the four corners.
- Using a chisel, pry off the roof panel along the bold lines as shown.
- Center punch around the spot weld imprints of the roof gutter welded flange.
- Drill holes using the spot cutter.
- Using a chisel, pry off the welded flange.

OUTER PANEL

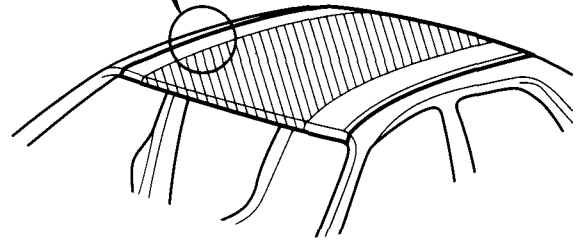
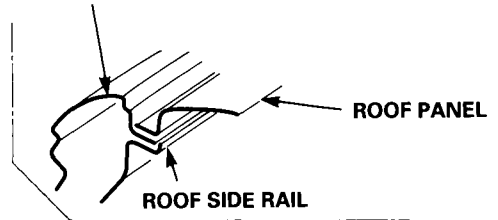

<Front>

ROOF PANEL

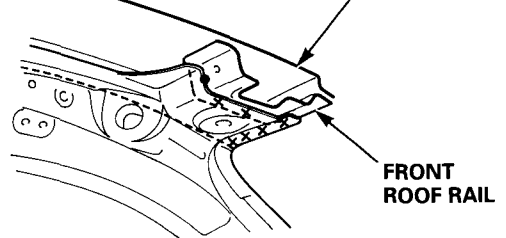

<Rear>

4-Door/2-Door:

Forward →

ROOF PANEL

REAR ROOF RAIL

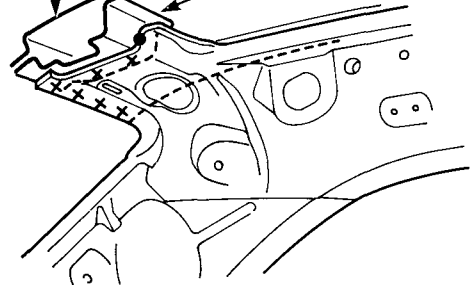

3-Door:

ROOF PANEL

REAR ROOF UPPER RAIL

REAR ROOF LOWER RAIL

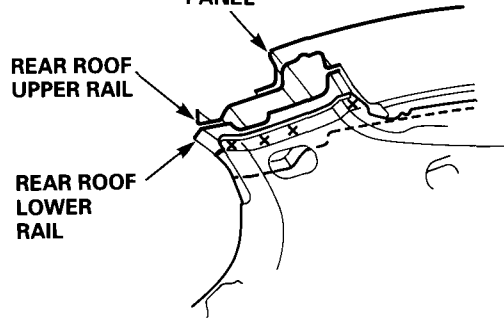

(cont'd)

# Roof Panel

## Replacement (cont'd)

NOTE: If necessary, replace the outer panel.

When replacing the outer panel, drill holes with a spot cutter at the area joined to the front roof side rail, rear roof side rail and rear inner panel.

### 4-Door/2-Door:

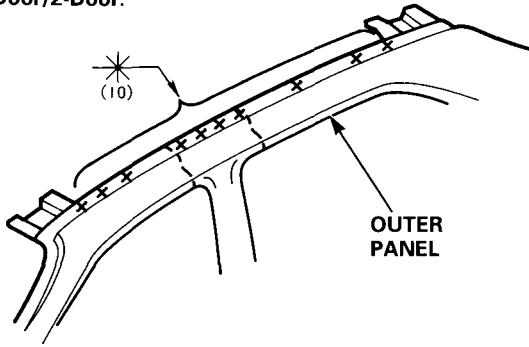

### 3-Door:

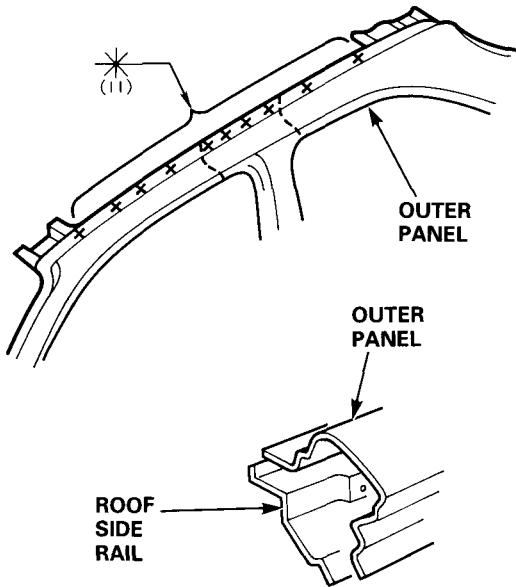

#### 5. Model the related parts.

- Weld the holed areas with a MIG or gas welder.

**WARNING** To prevent eye injury and burns when welding, wear an approved welding helmet, gloves and safety shoes.

- Level and finish burrs on the welded flanges with a disc sander.

**WARNING** To prevent eye injury, wear goggles or safety glasses whenever sanding, cutting or grinding.

- Even out the roof side rail welded flange with a hammer and dolly for a close fit with the roof panel welded flange.

#### 6. Tack weld the outer panel.

**WARNING** To prevent eye injury and burns when welding, wear an approved welding helmet, gloves and safety shoes.

#### 7. Apply paint to the underside of the new roof panel.

- See Paint Repair section.

**WARNING**

- Ventilate when spraying paint. Most paint contains substances that are harmful if inhaled or swallowed. Read the paint label before opening the paint container.
- Avoid contact with skin. Wear an approved respirator, gloves, eye protection and appropriate clothing when painting.
- Paint is flammable. Store it in a safe place, and keep it away from sparks, flames or cigarettes.

#### 8. Set the new roof panel and outer panel.

- Sand off the undercoat from both sides of the flange sections to be spot welded to expose the steel plate.

**WARNING** To prevent eye injury, wear goggles or safety glasses whenever sanding, cutting or grinding.

- Clamp the roof panel with vice-grips.

NOTE:

- Check that the flange surfaces fit closely. Be careful not to twist or deform the roof panel.
- Check the width of the groove for the roof moldings on both sides.
- Apply the spot sealer to the welding surface when spot welding.

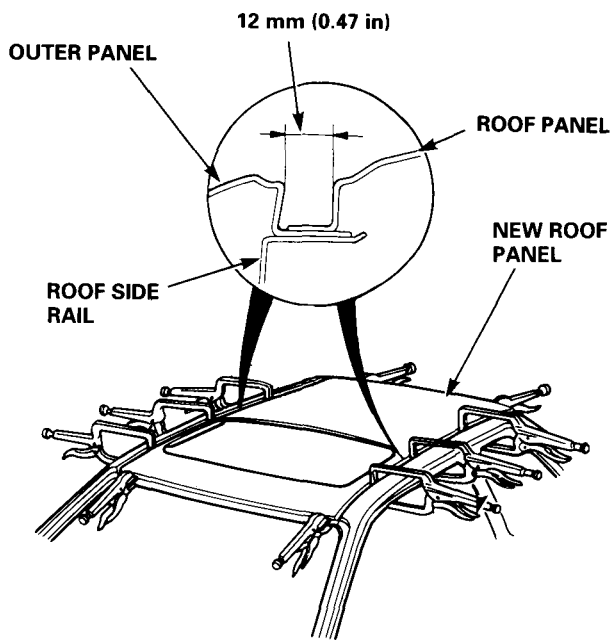

- Check the body dimension (see [section 6](#)).
- Remove the new roof panel
- Main weld the outer panel and roof side rail.

**⚠ WARNING** To prevent eye injury and burns when welding, wear an approved welding helmet, gloves and safety shoes.

9. Tack weld the new roof panel.

**⚠ WARNING** To prevent eye injury and burns when welding, wear an approved welding helmet, gloves and safety shoes.

- Spot weld the clamped sections to temporarily install the roof panel.
- Set the windshield and rear window (4-door/2-door) or hatch (3-door), and check the roof panel for proper installation.
- Install the roof molding and check the width of the groove.

10. Perform the main welding.

**⚠ WARNING** To prevent eye injury and burns when welding, wear an approved welding helmet, gloves and safety shoes.

- Spot weld the roof rails at the front and rear.
- Spot weld the roof arch.
- Make 20% to 30% more spot welds than there were holes drilled.

- Smooth the spot weld areas under the windshield and rear window with a hammer and dolly.

NOTE: After welding the pillars, grind and finish the welded areas flat and blend them into the roof panel.

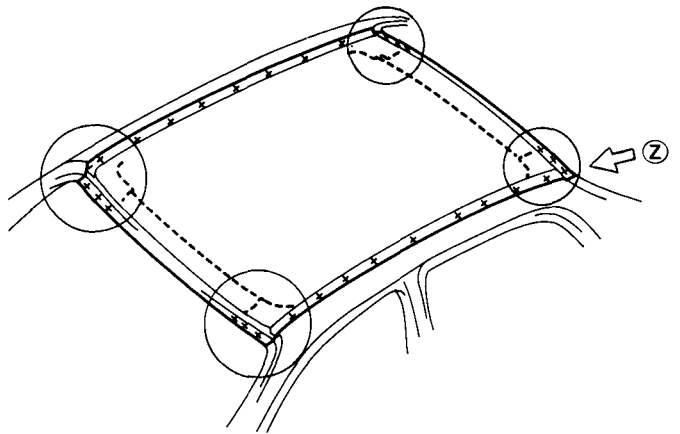

3-Door:

VIEW Z

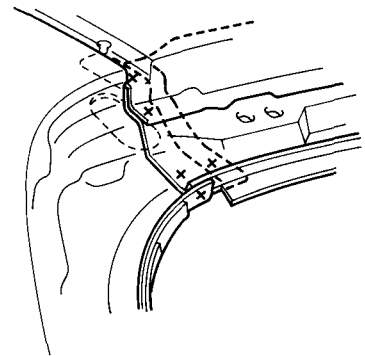

- Weld the roof rail from the inside by MIG welding as shown.

**⚠ WARNING** To prevent eye injury and burns when welding, wear an approved welding helmet, gloves and safety shoes.

(Front)

Forward

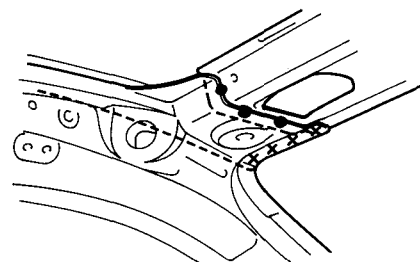

(cont'd)

# Roof Panel

## Replacement (cont'd)

(Rear)

**4-Door/2-Door:**

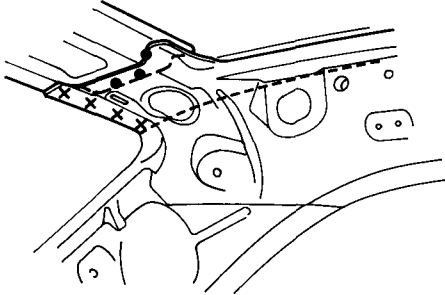

**3-Door:**

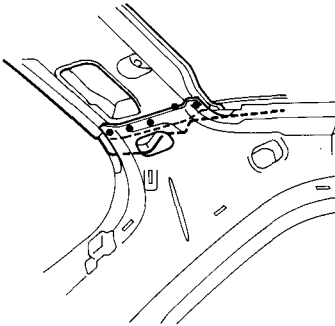

11. Apply and level the sealer to the welded areas (see [section 5](#)).

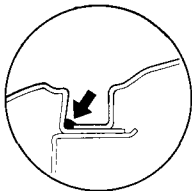

12. Apply the paint.  
See Paint Repair section.

**⚠ WARNING**

- Ventilate when spraying paint. Most paint contains substances that are harmful if inhaled or swallowed. Read the paint label before opening the paint container.
- Avoid contact with skin. Wear an approved respirator, gloves, eye protection and appropriate clothing when painting.
- Paint is flammable. Store it in a safe place, and keep it away from sparks, flames or cigarettes.

13. Apply an anti-rust agent to the inside of the roof side rail.

14. Install the related parts.  
Install in the reverse order of removal.

15. Check and clean.
- Check the windshield and rear window for water leaks.
  - Adjust the clearance with the hatch, then adjust the level differences and fit. Check operation (3 door).
  - Make sure the moonroof operates smoothly.
  - Clean the passenger compartment thoroughly.

# Rear Side Outer Panel

## Description

The rear side outer panel is a conspicuous part of the vehicle. It is especially important for the body line continuing from the door. Therefore, pay particular attention to it when conducting work. This part must also be aligned with the hatch, the rear door, the quarter glass and other parts.



# Rear Side Outer Panel

## Mass Production Body Welding Diagram

4-Door:

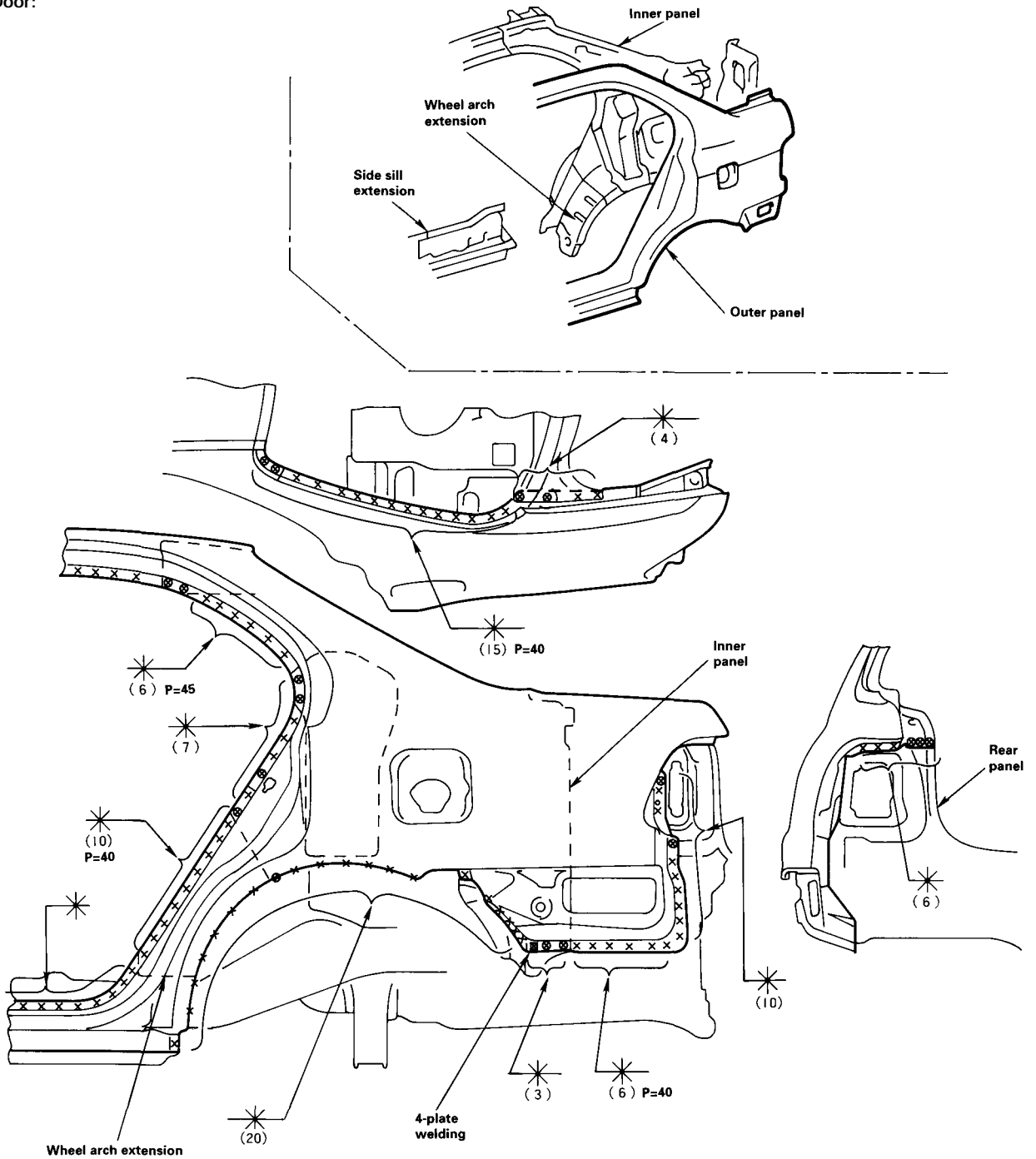

(cont'd)

# Rear Side Outer Panel

## Mass Production Body Welding Diagram (cont'd)

3-Door:

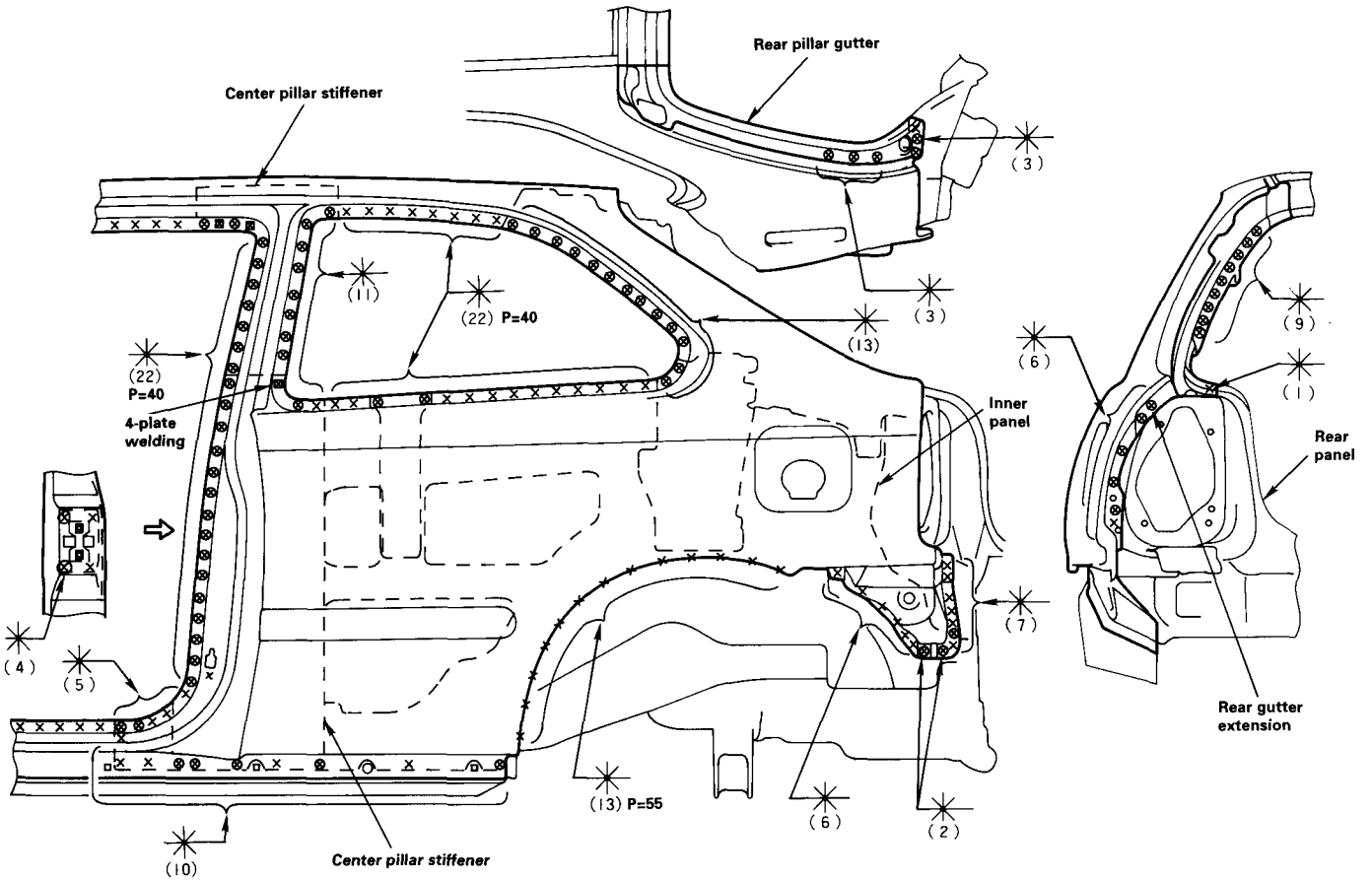
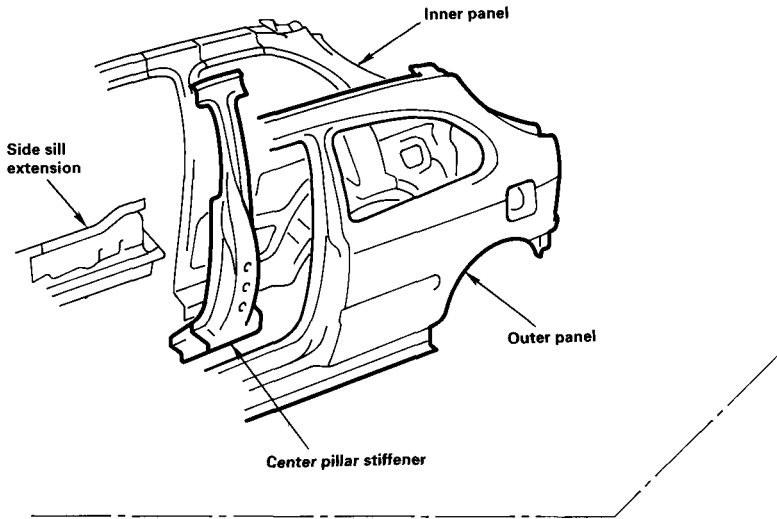

2-Door:

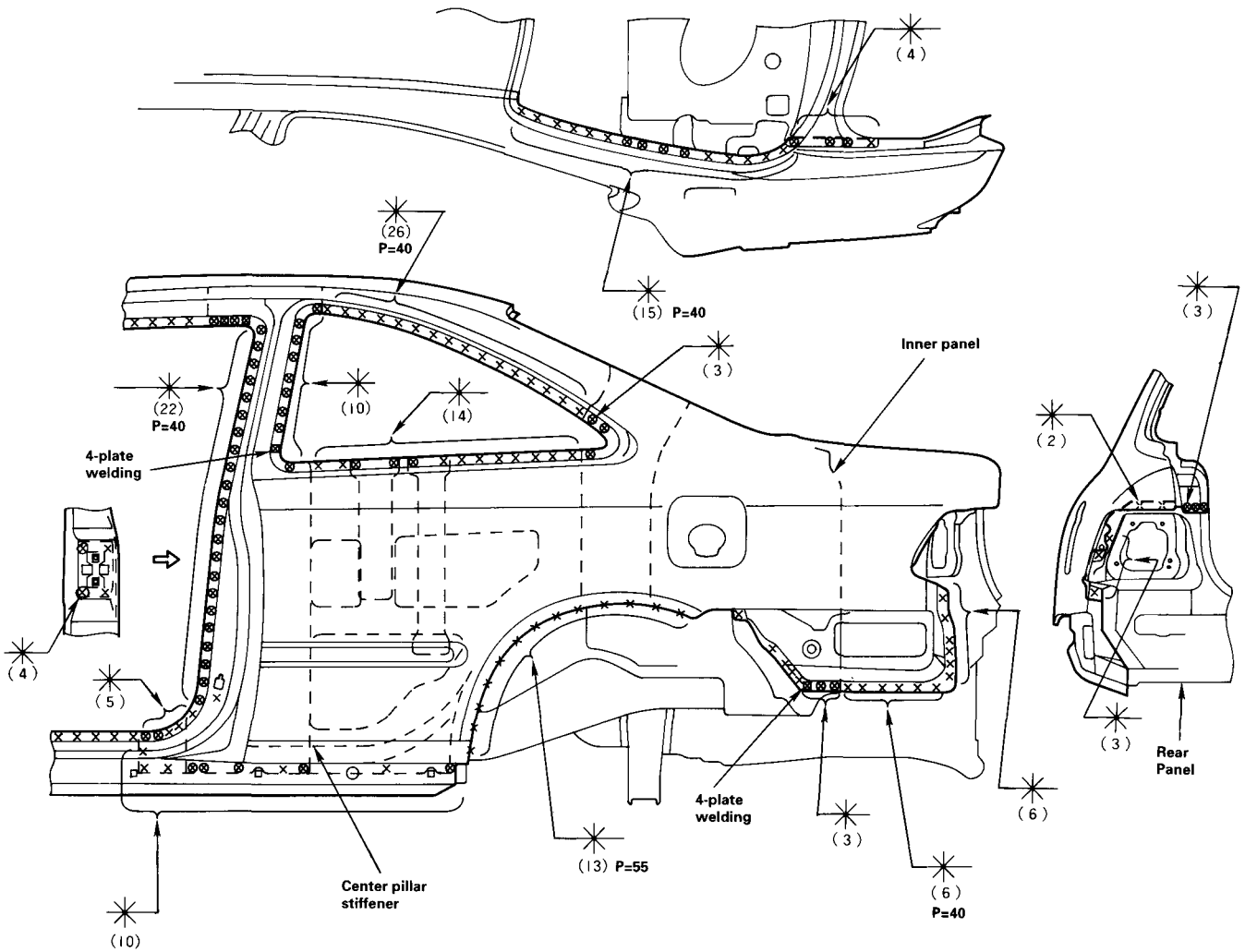
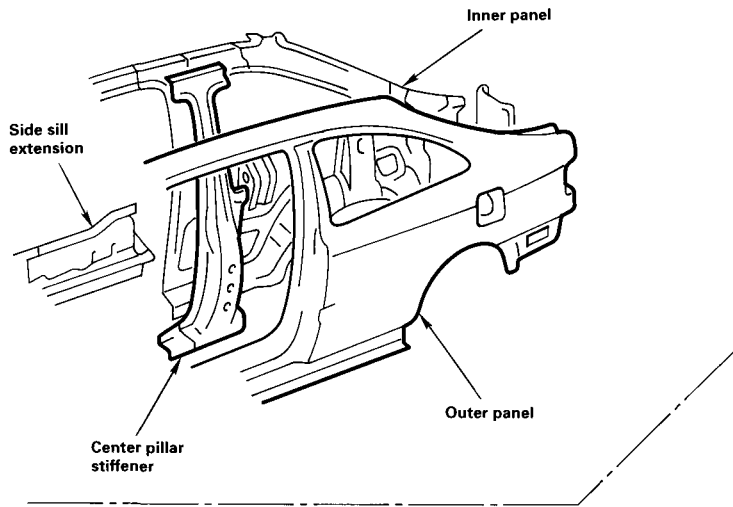

# Rear Side Outer Panel

## Replacement

1. Remove the related parts.
  - Trunk lid(4-door/2-door)
  - Rear bumper/Rear panel upper skirt (4-door/2-door)
  - Rear window (4-door/2-door)
  - Hatch (3-door)
  - Quarter glass (3-door/2-door)
  - Taillight
  - Rear pillar trim panel
  - Trunk side panel
  - Rear seat
  - Rear seat belt
  - Fuel fill pipe (left side only)

**⚠ WARNING** Do not smoke while working near the fuel system. Keep open flame away from the fuel system. If necessary, remove the fuel tank and/or lines before welding nearby. Drain fuel into an approved container.

2. Pull out and straighten the damaged area.

NOTE: Carefully check the inner pillar and rear pillar gutter for position and damage. Pull out the inner panel by cutting the outer if necessary.

- Jack-up the body and place safety stands at the four designated support points.
- Pull out the damaged rear side outer panel with the frame straightener, then pull out and straighten the center pillar inner panel and rear wheelhouse.

NOTE: Be careful not to pull out more than necessary.

- After pulling, check the inner pillar and rear pillar gutter position using the body dimensional drawings (see [section 6](#)).

3. Cut and pry off the rear side outer panel.

- Cut at the rear pillar and side sill with a handsaw.
- Cut the panel from the body with a chisel leaving the weld flange at the inner panel intact.

NOTE: Do not cut or damage the inner panel and rear damper stiffener.

- Cut at the side sill or wheel arch according to the extent of the damage.
- Center punch around the spot weld imprints on the remaining flange.
- Drill out the spot welds with the spot cutter.
- Pry off the welded flange sections using a chisel.

**⚠ WARNING** Do not smoke while working near the fuel system. Keep open flame away from the fuel system. If necessary, remove the fuel tank and/or lines before welding nearby. Drain fuel into an approved container.

NOTE: Do not damage the rear damper stiffener.

4-Door:

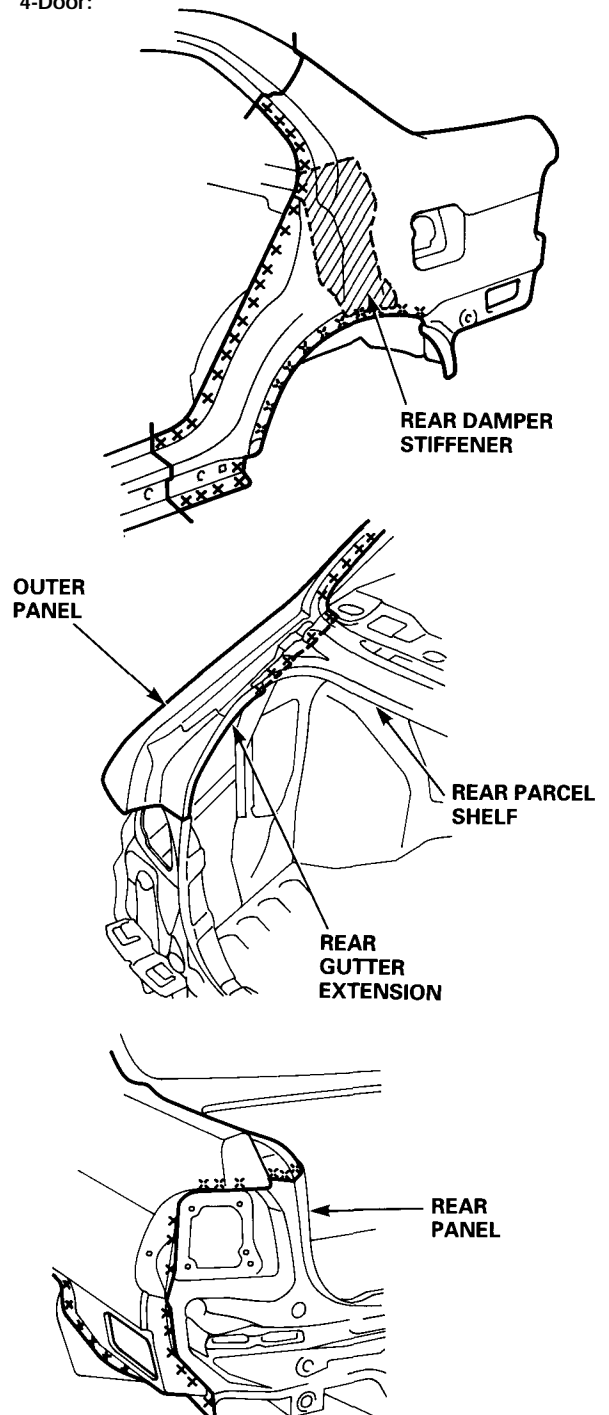

3-Door:

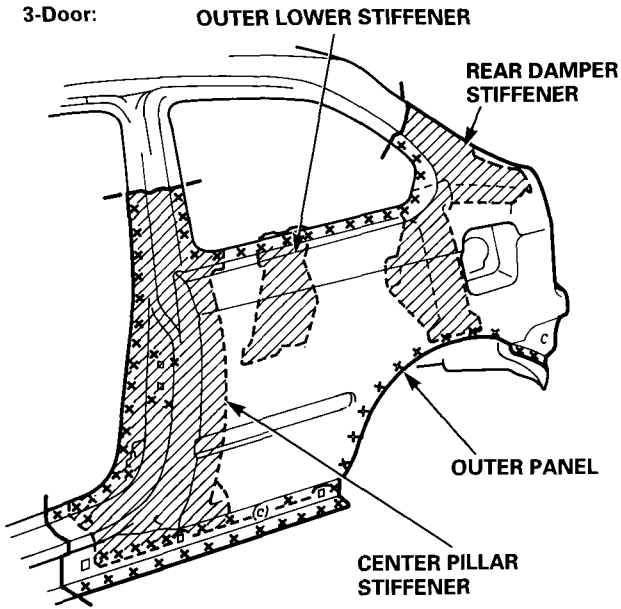

OUTER PANEL

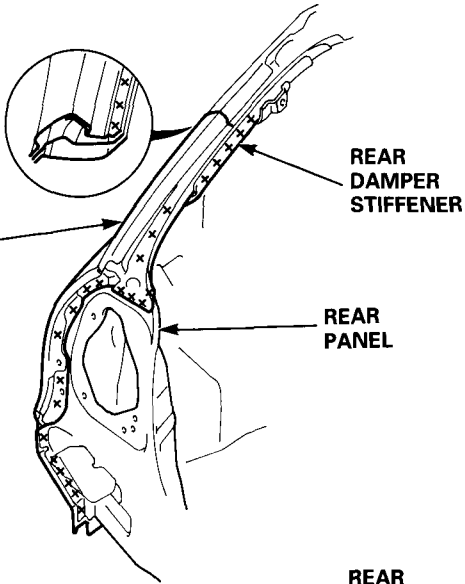

2-Door:

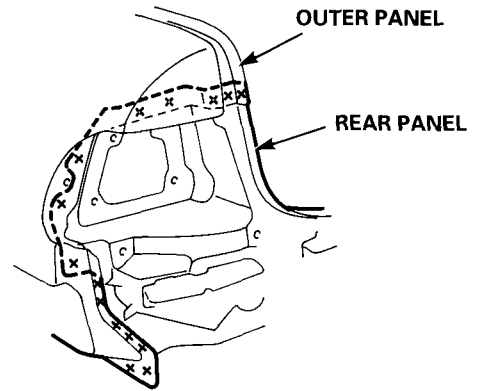
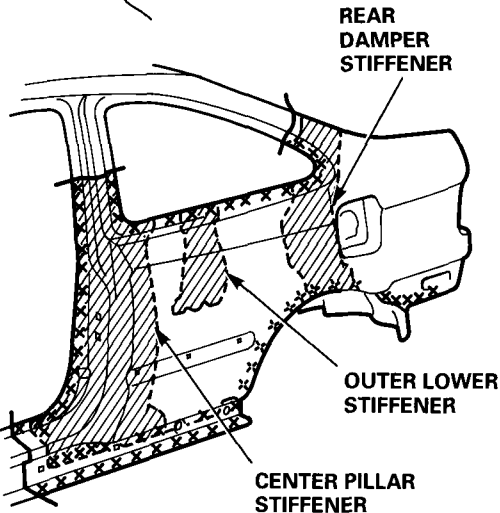

4. Mold the inner panel and related parts.

- Fill and holes drilled by MIG or gas welding.

**⚠ WARNING** To prevent eye injury and burns when welding, wear an approved welding helmet, gloves and safety shoes.

- Level and finish burrs, etc. with a disc sander.

**⚠ WARNING** To prevent eye injury, wear goggles or safety glasses whenever sanding, cutting or grinding.

4-Door:

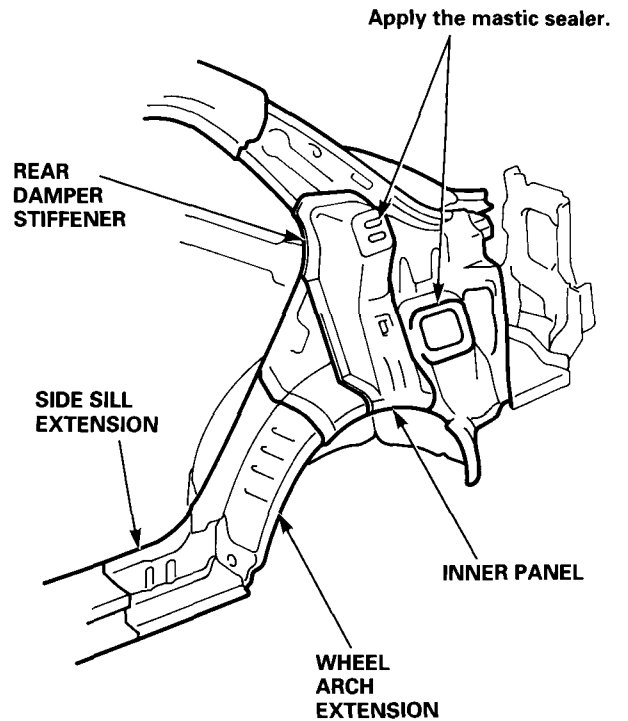

(cont'd)

# Rear Side Outer Panel

## Replacement (cont'd)

3-Door:

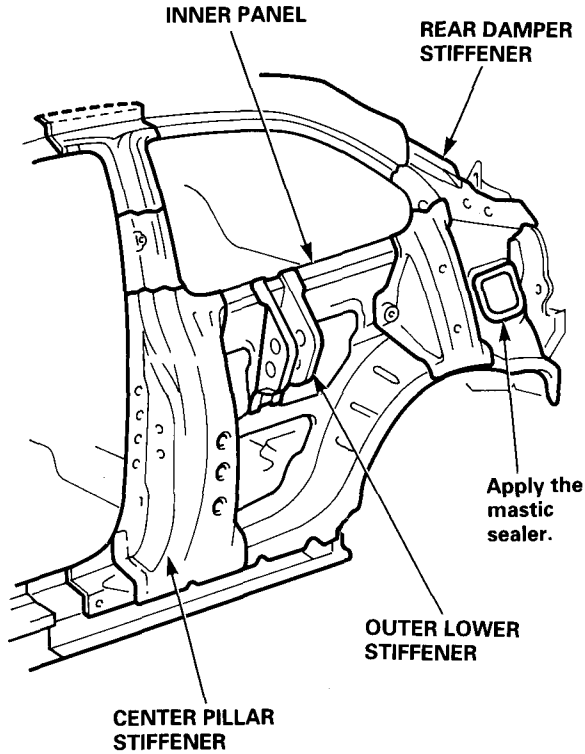

2-Door:

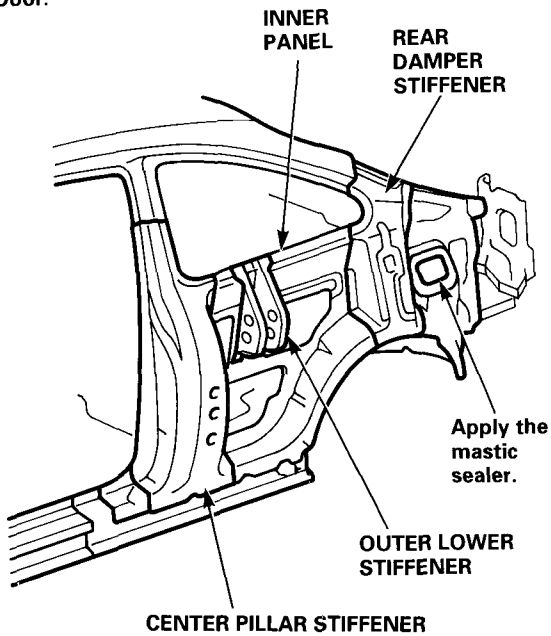

5. Cut the replacement part.
  - Cut so that the repair part overlaps the side sill by 30 mm (1.2 in).
  - Apply body paint to the back of the repair part.

- See Paint Repair section.

**⚠ WARNING**

- Ventilate when spraying paint. Most paint contains substances that are harmful if inhaled or swallowed. Read the paint label before opening the paint container.
- Avoid contact with skin. Wear an approved respirator, gloves, eye protection and appropriate clothing when painting.
- Paint is flammable. Store it in a safe place, and keep it away from sparks, flames or cigarettes.
- Remove the undercoat from both sides of the weld flange with a sander to expose the steel plate.
- Cut the repair part at the rear pillar with a handsaw.

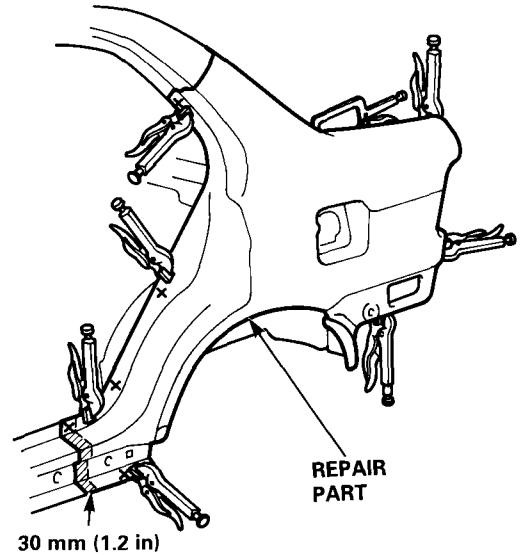

6. Set the repair part.
  - Install the outer panel and clamp it with vise-grips.

NOTE: Apply the spot sealer to the welding surface when spot welding.

  - Check the body dimensions (see [section 6](#)).

7. Tack weld the repair part.

**⚠ WARNING**

To prevent eye injury and burns when welding, wear an approved welding helmet, gloves and safety shoes.

Temporarily spot weld the panel at the clamped positions.

8. Remove the vise-grips and check the alignment of the trunk lid (4-door/2-door), hatch (3-door) and door.

NOTE:

- Check for flushness of the front fender, door, and the rear fender and make sure the body lines flow smoothly.
- Check the rear window opening (4-door/2-door), hatch and quarter window openings (3-door/2-door).

9. Perform the main welding.

**▲ WARNING** To prevent eye injury and burns when welding, wear an approved welding helmet, gloves and safety shoes.

- Weld the outer panel at the rear pillar and side sill with a MIG welder.
- Make 20% to 30% more spot welds than there were holes drilled.
- Make 5 mm (0.2 in) hole in the MIG weld hole with the repair part, and wheel arch extension, center pillar stiffener and inner panel (3-door/2-door) with a MIG welder.

**4-Door:**

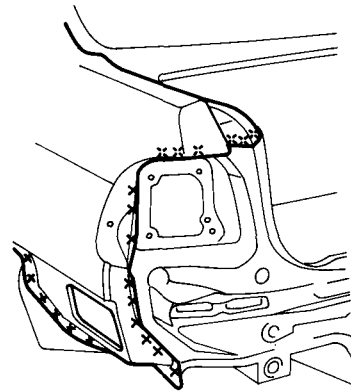
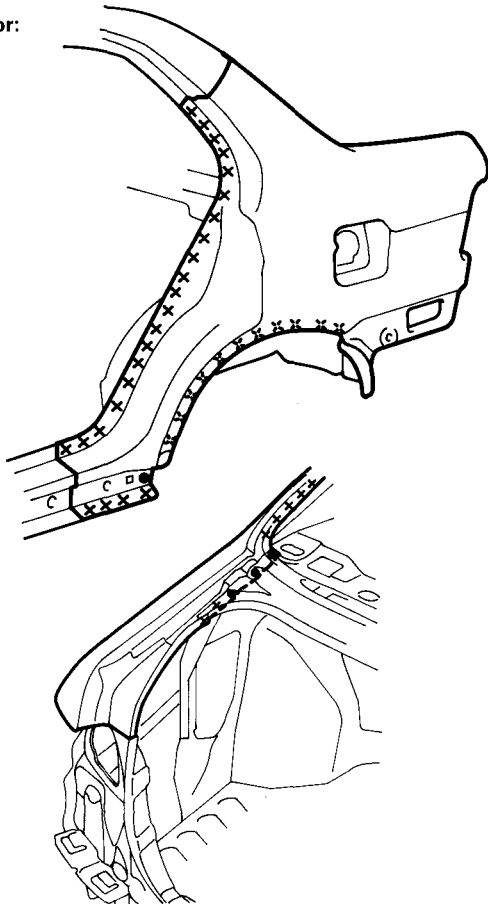

**3-Door:**

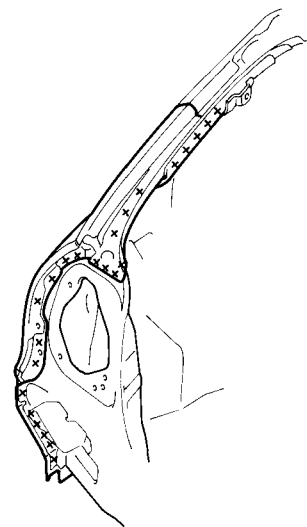
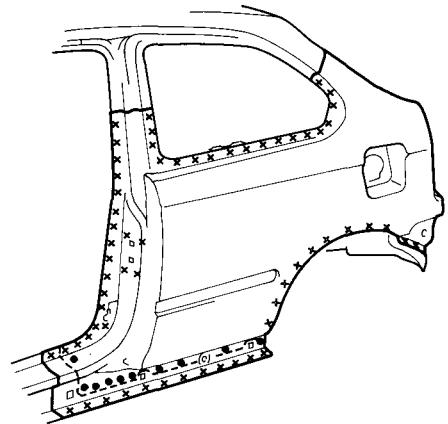

(cont'd)

# Rear Side Outer Panel

## Replacement (cont'd)

### 2-Door

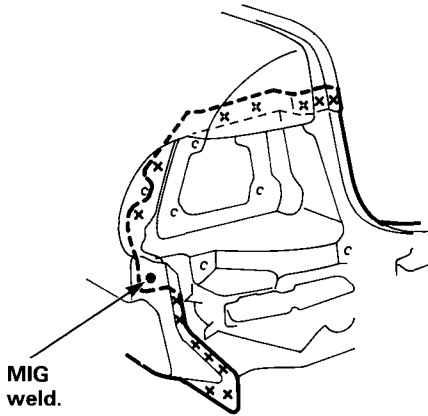
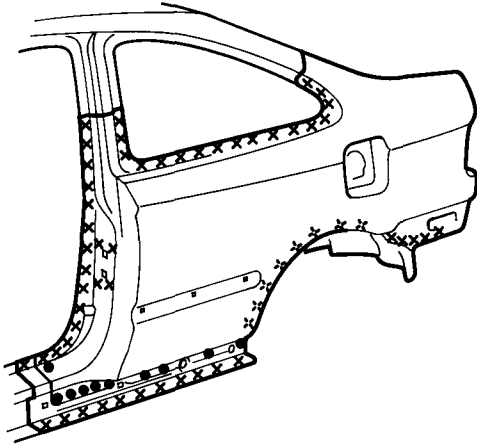

10. Finish the welded areas.

- Level the MIG welded areas with a disc sander.

**⚠ WARNING** To prevent eye injury, wear goggles or safety glasses whenever sanding, cutting or grinding.

- Even out high areas with a hammer. Be careful not to deform them.
- Even out the spot welded flange areas with a hammer and dolly.
- Fill in deformations and level differences of the welded areas with solder or putty, then finish.

11. Apply the sealer (see [section 5](#)).

Apply sealer to the fuel fill section, trunk lid opening (4-door/2-door) or hatch opening (3-door) joint and around the taillight area of the rear panel.

12. Apply the paint.

See Paint Repair section.

**⚠ WARNING**

- Ventilate when spraying paint. Most paint contains substances that are harmful if inhaled or swallowed. Read the paint label before opening the paint container.
- Avoid contact with skin. Wear an approved respirator, gloves, eye protection and appropriate clothing when painting.
- Paint is flammable. Store it in a safe place, and keep it away from sparks, flames or cigarettes.

13. Apply the undercoat.

Apply undercoat to the wheelhouse and apply anti-rust agent to the inside of the outer panel (see [section 7](#)).

14. Install the related parts.

Install in the reverse order in which they were removed.

15. Inspect, check, and clean.

- Adjust the clearance with the door and trunk lid (4-door/2-door) or hatch (3-door), then adjust the level differences and fit. Check operation.
- Test for leaks in the trunk and passenger compartments.
- Check the hatch opening for water leaks.
- Clean the trunk floor.



# Rear Panel

## Description

The rear panel is joined to the rear outer panel and the rear floor, and it maintains the rigidity of both sides of the body. Weld the rear panel carefully.

## Mass Production Body Welding Diagram

4-Door/2-Door:

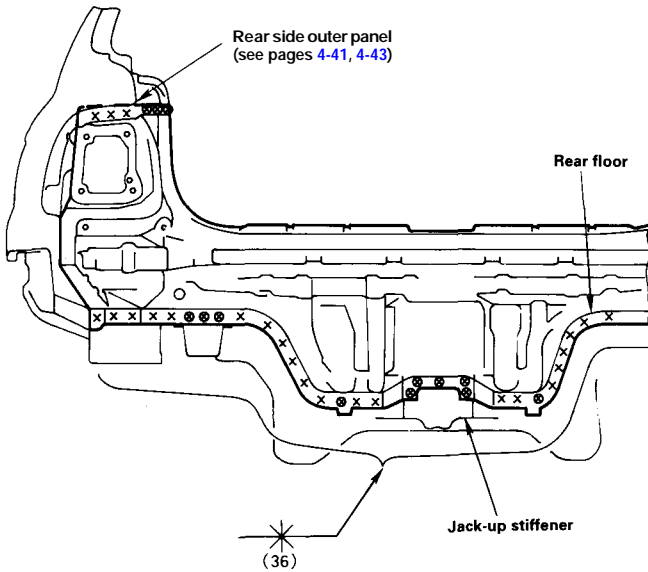

3-Door:

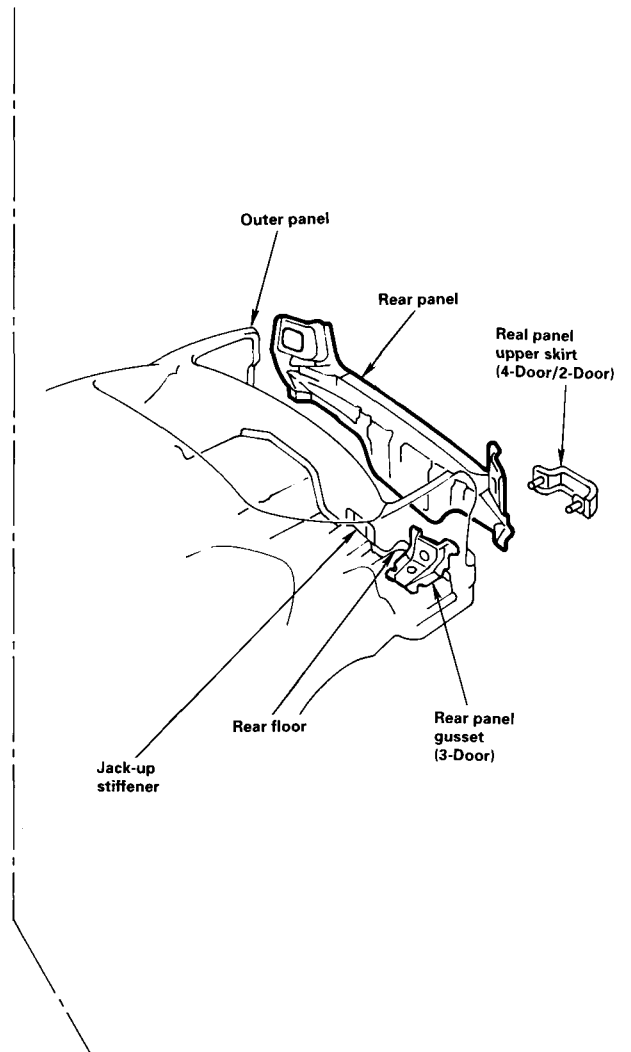
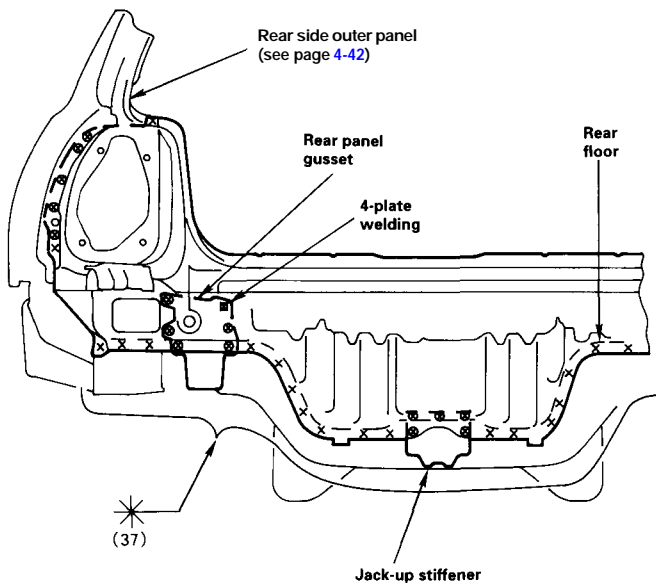

# Rear Panel

## Replacement

1. Remove the related parts.
  - Rear bumper/Rear panel upper skirt (4-door/2-door)
  - Trunk lid (4-door/2-door)
  - Hatch (3-door)
  - Hatch (3-door)
  - Other related parts
  - Rear and side trim panels
  - Taillights
2. Pull out and straighten the damaged area.
  - Pull out the related rear side inner panel, rear floor, rear frame and other damaged parts with the frame straightener.
  - Attach the car to the frame straightener by tightening the underbody clamps located at the jack-up points on the bottom of the side sill and the side sill side flanges.
3. Cut and pry off the rear panel.
  - Cut along the bold line shown with a gas cutter or an air chisel and remove the rear panel.
  - Center punch around the spot weld imprints with the rear side outer panel and rear floor.
  - Drill holes using the spot cutter.

NOTE: Be careful not to let holes penetrate through to the rear floor.

- Remove weld flange with a chisel.

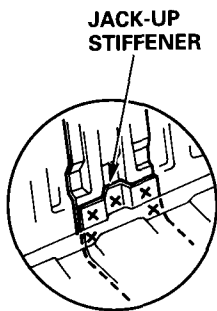

4-Door/2-Door

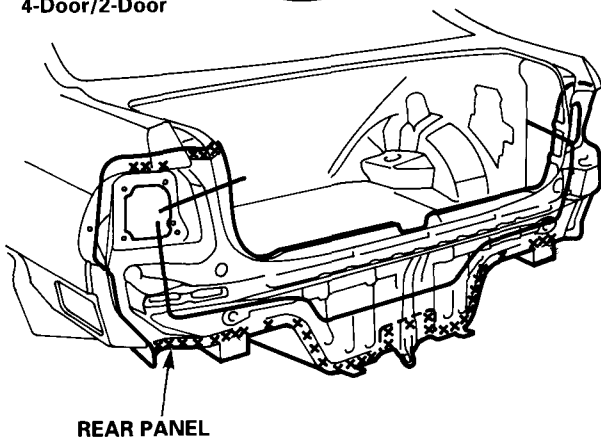

3-Door

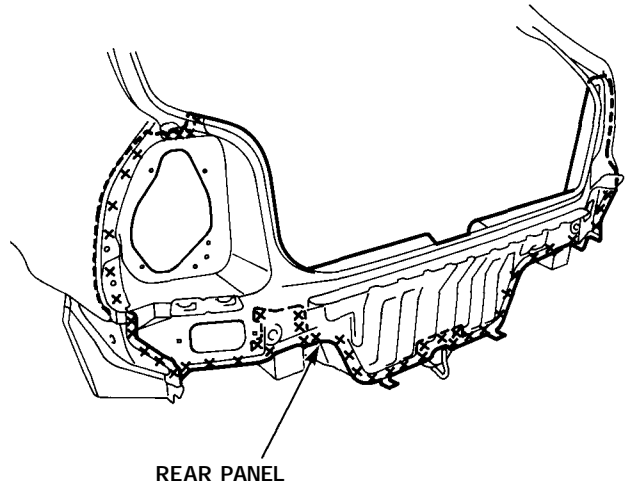

4. Mold the related parts.

Repair all cracks, holes or other defects by MIG or gas welding.

**⚠ WARNING** To prevent eye injury and burns when welding, wear an approved welding helmet, gloves and safety shoes.

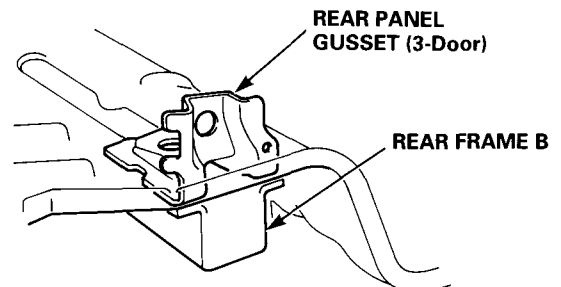
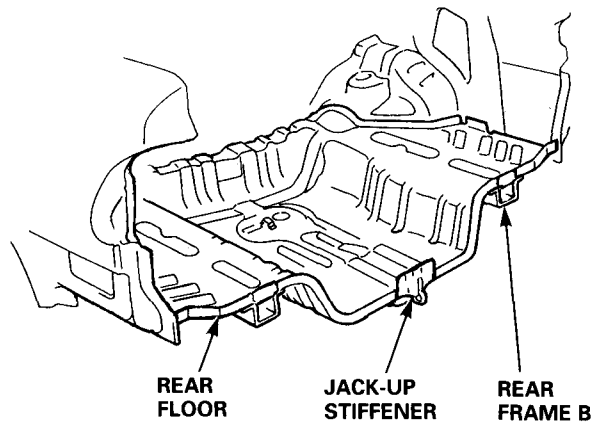

5. Set the new rear panel.
  - Paint the inside of the panel with the body color.
  - See Paint Repair section.

**▲ WARNING**

- Ventilate when spraying paint. Most paint contains substances that are harmful if inhaled or swallowed. Read the paint label before opening the paint container.
  - Avoid contact with skin. Wear an approved respirator, gloves, eye protection and appropriate clothing when painting.
  - Paint is flammable. Store it in a safe place, and keep it away from sparks, flames or cigarettes.
- 
- Remove the undercoat from the welding section of the panel and expose the steel plate using a disc sander.

**▲ WARNING** To prevent eye injury, wear goggles or safety glasses whenever sanding, cutting or grinding.

- Install the new rear panel and clamp it with vise-grips.

NOTE: Apply the spot sealer to the welding surface when spot welding.

- Check the rear panel position using the body dimensional drawings (see [section 6](#)).

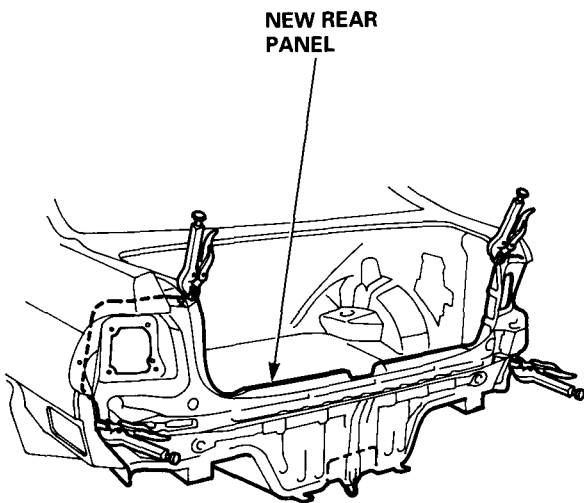

6. Tack weld the rear panel.
  - Weld the clamped sections for temporary installation.

**▲ WARNING**

To prevent eye injury and burns when welding, wear an approved welding helmet, gloves and safety shoes.

7. Open and close the trunk lid (4-door/2-door) or hatch (3-door) to check for proper installation.

NOTE: Make sure the trunk lid (4-door/2-door) or hatch (3-door) locks securely.

Position the rear panel in its correct position with the rear bumper and taillight installed.

8. Perform the main welding.

**▲ WARNING**

To prevent eye injury and burns when welding, wear an approved welding helmet, gloves and safety shoes.

- Make 20% to 30% more spot welds than there were holes drilled.

**4-Door/2-Door:**

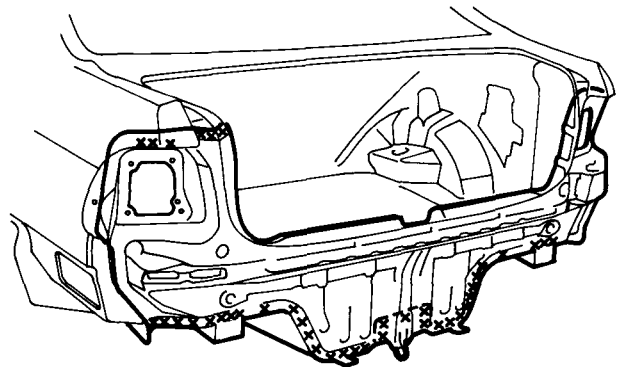

**3-Door:**

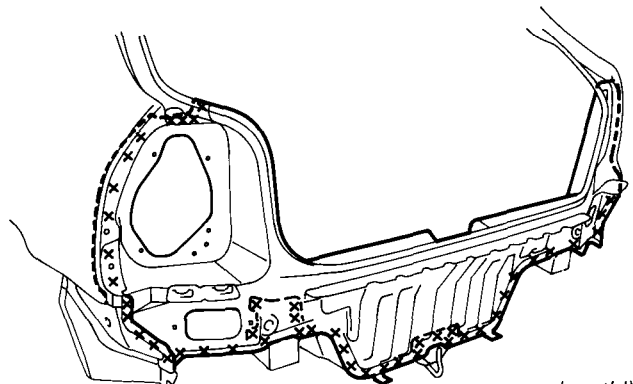

(cont'd)

# Rear Panel

## Replacement(cont'd)

9. Finish the welding area.

- Level the welded areas with a disc sander, then even out high areas with a hammer. Be careful not to deform them.

**⚠ WARNING** To prevent eye injury, wear goggles or safety glasses whenever sanding, cutting or grinding.

- Even out the spot welded flange area with a hammer and dolly.

10. Apply the sealer (see [section 5](#)).

- Apply sealer to the rear side outer joint and around the taillight areas of the rear panel.
- Apply sealer to the rear panel and rear floor joint.

11. Apply the paint.

See Paint Repair section.

- ⚠ WARNING**
- **Ventilate when spraying paint.** Most paint contains substances that are harmful if inhaled or swallowed. Read the paint label before opening the paint container.
  - **Avoid contact with skin.** Wear an approved respirator, gloves, eye protection and appropriate clothing when painting.
  - **Paint is flammable.** Store it in a safe place, and keep it away from sparks, flames or cigarettes.

12. Apply anti-rust agent (see [section 7](#)).

- Apply agent to the outer panel, rear panel and rear floor joint.
- Apply agent to the inside of the jack-up stiffener.

13. Install the related parts.

Install in the reverse order in which they were removed.

14. Inspect, check, and clean.

- Adjust the clearance with the trunk lid (4-door/2-door) or hatch (3-door) then adjust the level differences and fit. Check operation.
- Test for leaks in the trunk compartment.
- Clean the trunk floor.

# Rear Floor

## Description

The rear floor is the base of the rear body, and it is critical for the rigidity of the rear body. During replacement, refer to the body dimension chart or body correction chart, and determine the position to set the rear floor properly. Be sure that the rear floor is not bent or deformed. Weld securely following the welder manufacturer's instructions to maintain the rigidity of the body.

## Mass Production Body Welding Diagram

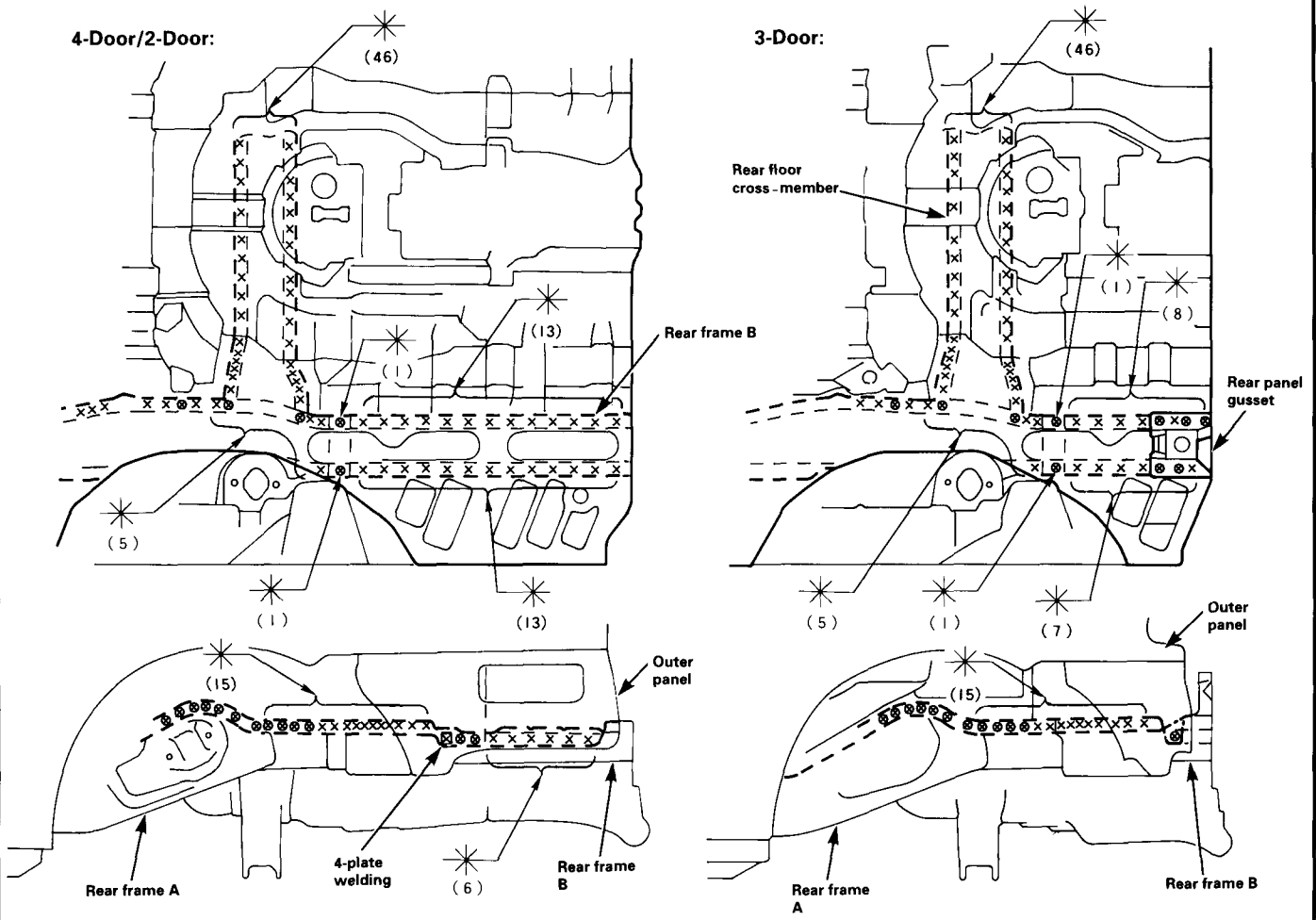
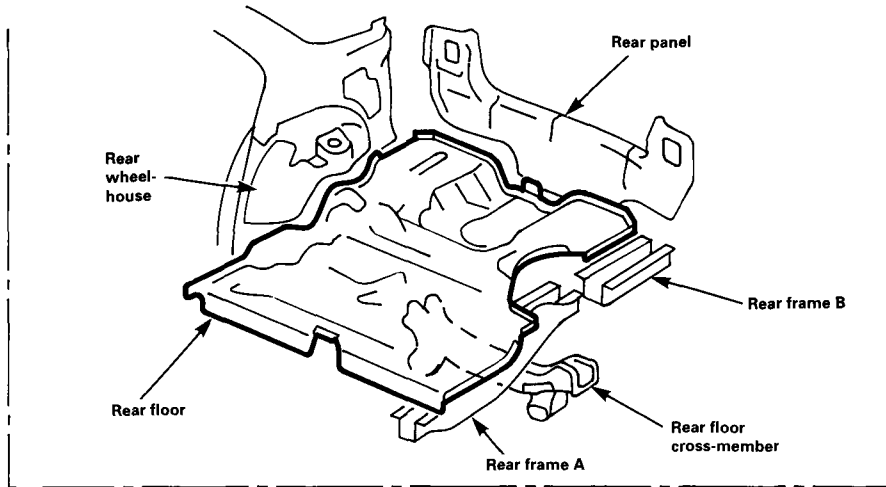

# Rear Floor Replacement

- Remove the related parts.
  - Rear seat
  - Trim and other luggage compartment fittings
  - Left and right rear suspension assembly
  - Parking brake parts
  - Muffler
  - Wire harness
  - Other parts as necessary
  - Fuel tank and fuel pipes

**⚠ WARNING** Do not smoke while working near the fuel system. Keep open flame away from the fuel system. If necessary, remove the fuel tank and/or lines before welding nearby. Drain fuel into an approved container.

- Pull out and straighten the damaged area.
  - Check whether the damage extended to the rear floor cross-member, rear wheelhouse and the passenger compartment, and pull out the damaged parts using the frame corrector.
  - Impact damage to the rear floor spreads to related parts such as the rear frame, rear floor cross-member and rear wheelhouse.
  - Therefore, pull out the damaged areas with the frame straightener and measure in reference to body dimensional drawing.

NOTE: Use of a positioning jig is recommended (see page 1-8).

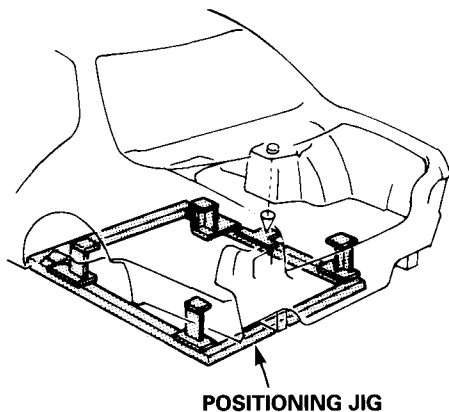

- Peel off the undercoat. Heat the undercoat at the weld areas of the lower rear floor with a gas torch and peel off the undercoat with a metal spatula.

**CAUTION:** Be careful not to burn the fittings inside the trunk compartment while heating.

- Cut and pry off the rear panel (see page 4-49).

- Cut and pry off the rear floor.
  - Cut off the rear floor with a gas cutter or air chisel. Level the spot welded flanges of the rear frame and rear floor cross-member, as shown by the bold line in the figure below.

NOTE: Cut the rear floor 15 mm (0.6 in) from the welded flange of the rear floor cross-member.

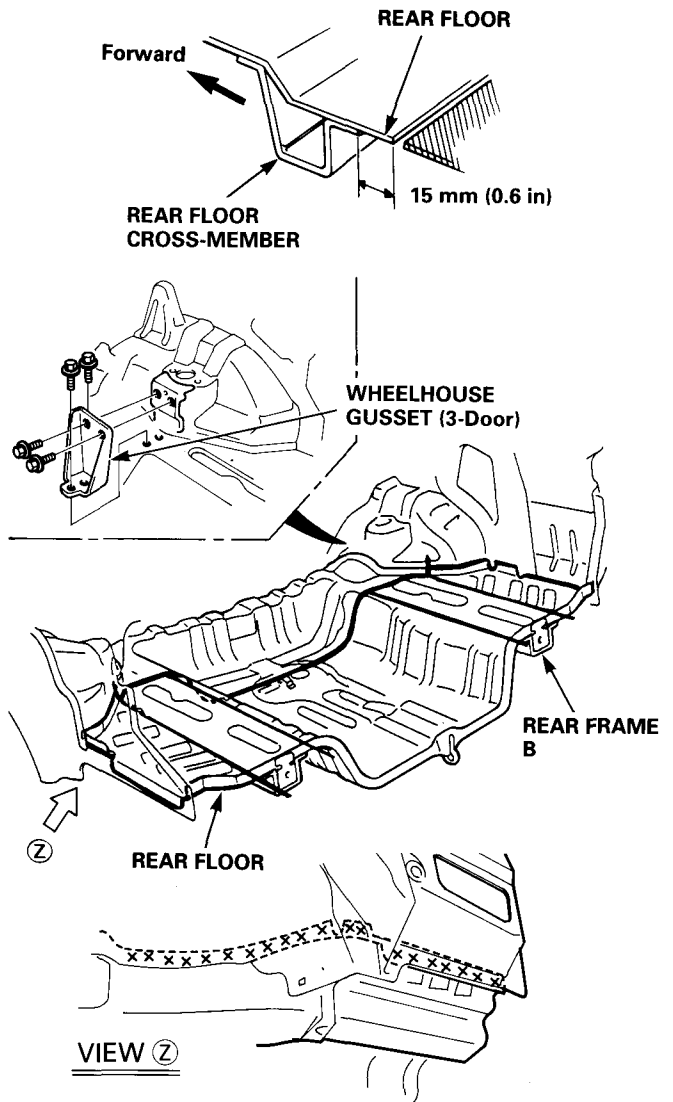

- Center punch around the spot weld imprints on the remaining welded flanges. Do the same with the rear wheelhouse and the side of the rear end inner panel.
- Drill holes with a spot cutter.

NOTE: When drilling holes, be careful not to drill down to the rear frame.

- Pry off the flanges using a chisel.

6. Mold the related parts.
- Remove the burrs from the spot weld or MIG weld using a sander.

**⚠ WARNING** To prevent eye injury, wear goggles or safety glasses whenever sanding, cutting or grinding.

- Fill any holes made in the spot welded areas of the flange by gas welding.

**⚠ WARNING** To prevent eye injury and burns when welding, wear an approved welding helmet, gloves and safety shoes.

- Smooth the welding flanges of the rear frame with a hammer and dolly.

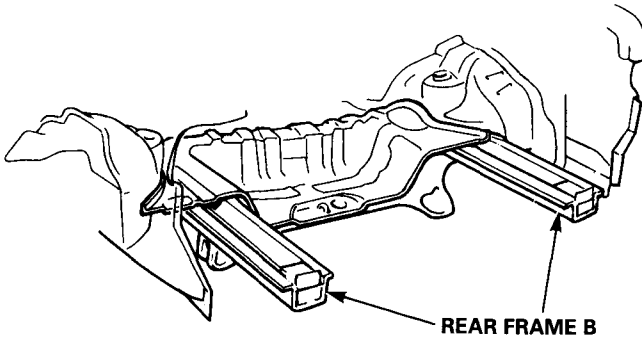

NOTE: If necessary, remove the rear frame B from the rear frame A.

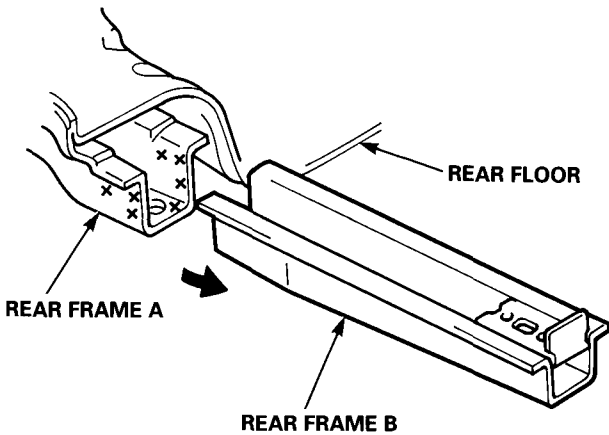

7. Keep the body level.  
Jack-up the body at the front and back. Place safety stands at the four designated places of the side sill.

8. Cut the new rear floor to align it with the body.
- Cut the new part so it overlaps the body side floor by approximately 40 mm (1.6 in).
  - Remove the undercoat from both sides of the areas to be welded with a sander to expose the steel plate.

**⚠ WARNING** To prevent eye injury, wear goggles or safety glasses whenever sanding, cutting or grinding.

NOTE: Check that the rear frame is parallel at the right and left.

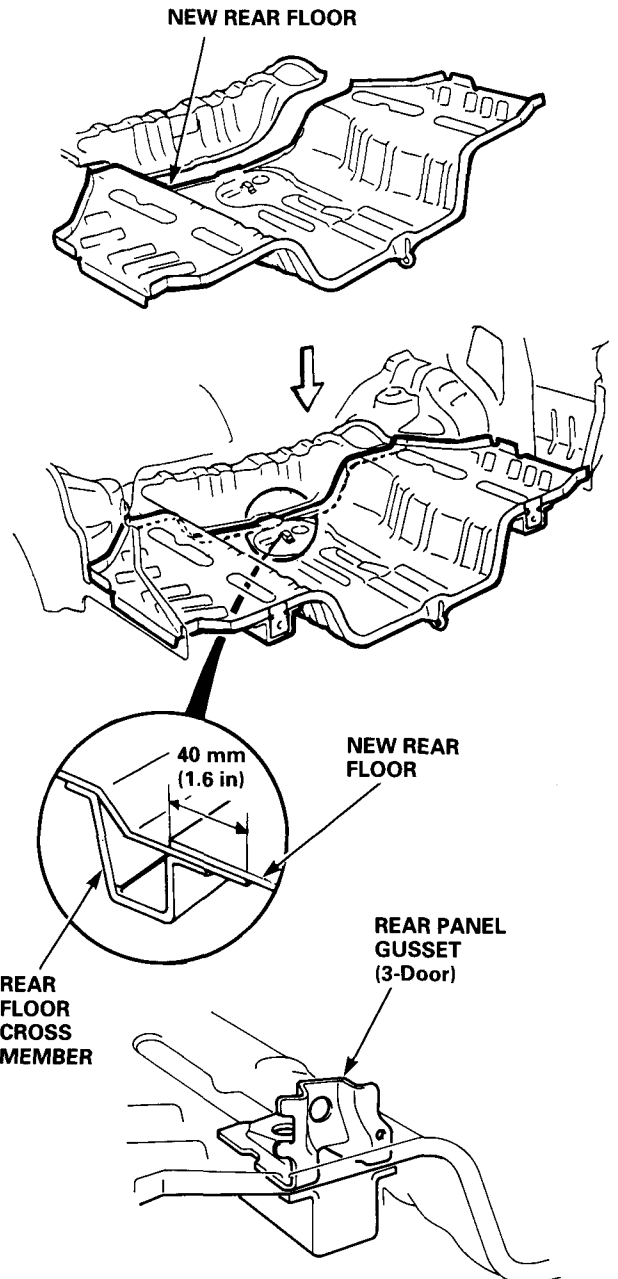

(cont'd)

# Rear Floor

## Replacement (cont'd)

9. Set the rear frame B and the new rear floor. Check the position of the rear frame A and B and the rear floor using the body dimensional drawings (see [section 6](#)) and the positioning jig.

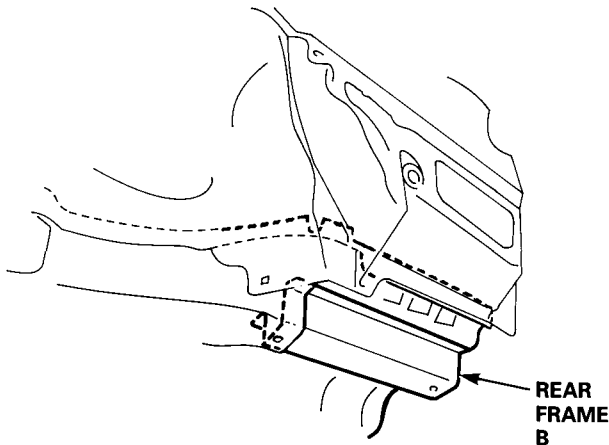

10. Perform the main welding.

**⚠ WARNING** To prevent eye injury and burns when welding, wear an approved welding helmet, gloves and safety shoes.

NOTE: Apply the spot sealer to the welding surface when spot welding.

### Spot welding:

Remove the new floor and weld the rear frame A and B securely. Recheck the position of the rear frames and rear floor, then weld the rear frame A, B and rear floor.

- Make 20% to 30% more spot welds than there were holes drilled.

### MIG welding:

- Drill the holes for welding the rear frame B.
- Clamp the rear frame B and floor. Check the rear frame position and weld the rear frame A and B by means of the MIG welding. Weld the rear floor to the rear frame.

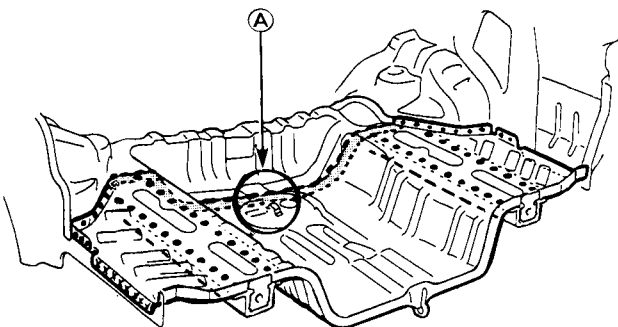

- Weld the overlap of the rear floor by MIG welding.

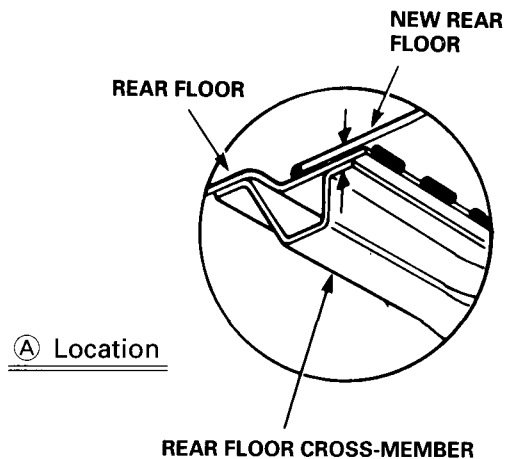

11. Finish the welded area.

Even out the welded area with a hammer and dolly, and fit the flange surfaces closely together.

12. Apply the sealer.

Apply sealer at the overlapped area of the rear floor, and the welded surfaces of the rear wheelhouse and rear end inner panel. Seal gaps completely (see [section 5](#)).

13. Apply the paint.

See Paint Repair section.

### ⚠ WARNING

- Ventilate when spraying paint. Most paint contains substances that are harmful if inhaled or swallowed. Read the paint label before opening the paint container.
- Avoid contact with skin. Wear an approved respirator, gloves, eye protection and appropriate clothing when painting.
- Paint is flammable. Store it in a safe place, and keep it away from sparks, flames or cigarettes.

14. Apply the undercoat.

Apply anti-rust agent to the inside of the jack-up stiffener and jointed areas of the rear floor (see [section 7](#)).

15. Weld the rear panel and install the related parts.

Install in the reverse order in which they were removed.

16. Inspect and clean.

- Measure the rear wheel alignment.
- Clean the inside of the trunk compartment.



# Rear Floor Cross-member

## Description

The rear floor cross-member position is critical for rear wheel alignment. During replacement, check the position of the rear beam and the rear damper base, and position the rear floor cross-member properly. Weld securely following the welder manufacturer's instructions to maintain rigidity. Use of the positioning jig is recommended.

## Mass Production Body Welding Diagram

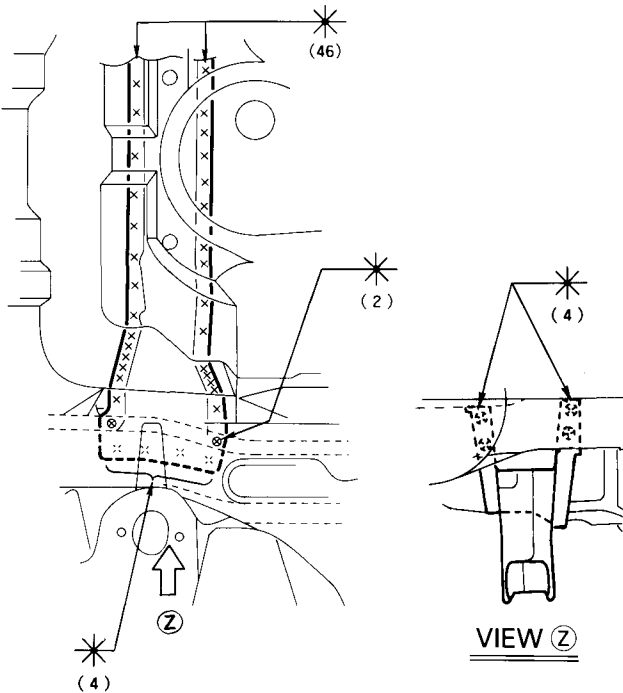
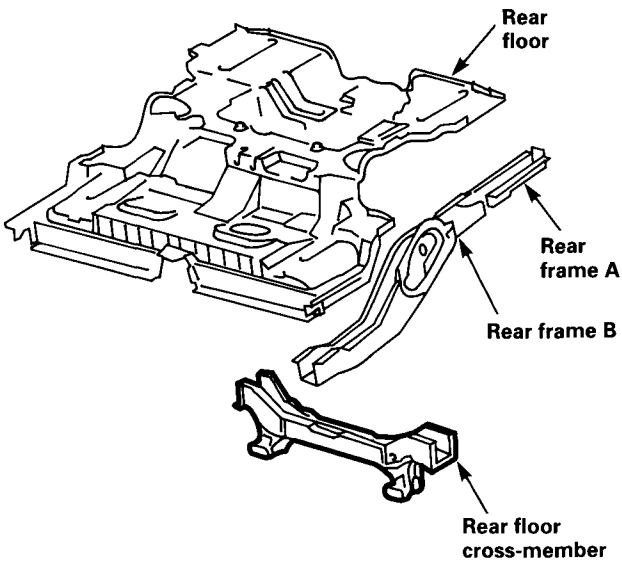

# Rear Floor Cross-member

## Replacement

1. See Rear Floor Replacement for removal of related parts.
2. Peel off the undercoat. Heat the undercoat at the weld areas of the rear floor and the rear frame with a gas torch, and peel off the undercoat with a metal spatula.

**CAUTION:** Be careful not to burn the fittings inside the trunk compartment when heating.

3. Remove the rear floor cross-member.

**⚠ WARNING** To prevent eye injury, wear goggles or safety glasses whenever sanding, cutting or grinding.

- Center punch around the spot weld imprints on the cross-member from inside the trunk compartment.
- Drill 5 mm (0.2 in) holes through the nuggets.
- Keep the holes to a minimum since they will be used as weld holes for MIG welding of the new part.

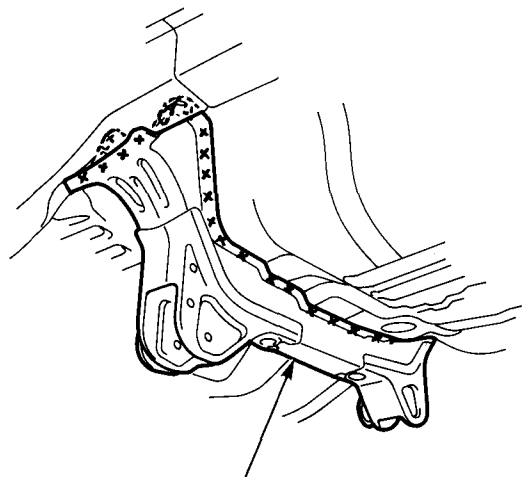

**REAR FLOOR  
CROSS-MEMBER**

- Center punch around the spot weld imprints on the rear frame.
- Drill holes with a spot cutter.
- Be careful not to let them penetrate through to the rear frame.
- Pry off the part with a chisel.

(cont'd)

# Rear Floor Cross-member

## Replacement (cont'd)

- Set the new rear floor cross-member.
  - Sand off undercoat from both sides of the areas to be welded to expose the steel plate.

**▲ WARNING** To prevent eye injury, wear goggles or safety glasses whenever sanding, cutting or grinding.

- Set the new rear floor cross-member in the original position properly and place a jack under the rear floor cross-member for support.

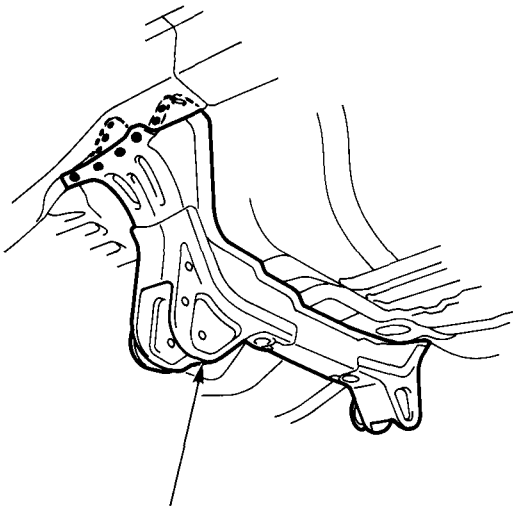

**NEW REAR FLOOR CROSS-MEMBER**

- Refer to the set position body dimensional drawings (see [section 6](#)) for proper positioning of the rear floor cross-member.
- Temporarily weld the mating surfaces with the rear frame.

**▲ WARNING** To prevent eye injury and burns when welding, wear an approved welding helmet, gloves and safety shoes.

- Check the rear floor cross-member in its correct position with the fuel tank installed.

- Perform the main welding.

**▲ WARNING** To prevent eye injury and burns when welding, wear an approved welding helmet, gloves and safety shoes.

- MIG weld the rear floor cross-member from the trunk compartment.

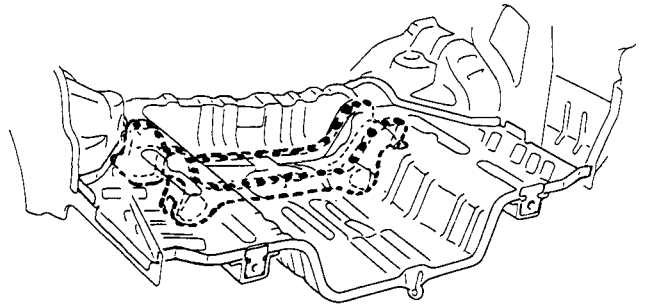

- Finish the welding area.  
Roughly grind the welds in the trunk compartment with a disc grinder. Be sure to leave the finishing allowance.

NOTE: Take care not to grind excessively.

- Apply the sealer (see [section 5](#)).

- Apply the paint.  
See Paint Repair section.

**▲ WARNING**

- Ventilate when spraying paint. Most paint contains substances that are harmful if inhaled or swallowed. Read the paint label before opening the paint container.
- Avoid contact with skin. Wear an approved respirator, gloves, eye protection and appropriate clothing when painting.
- Paint is flammable. Store it in a safe place, and keep it away from sparks, flames or cigarettes.

- Apply the undercoat (see [section 7](#)).
- Install the related parts.  
Install in the reverse order of removal.
- Check and clean.
  - Check the rear wheel alignment.
  - Clean the trunk compartment.

## Cross Section of Body and Sealants

Engine Compartment, Front Wheelhouse .....	5-2
Dashboard Upper/Front Pillar Inner Panel .....	5-3
Front Floor/Rear Floor .....	5-4
Roof Panel/Rear Outer Panel, Rear Panel (4-Door/2-Door) .....	5-5
Rear Outer Panel, Rear Panel (3-Door) .....	5-6
Rear Wheelhouse/Under Floor .....	5-7
Front and Rear Doors .....	5-8
Hood, Trunk Lid, Hatch/Hatch Spoiler .....	5-9

# Cross Section of Body and Sealants

NOTE: Seal the following areas to prevent air leaks, water leaks and rust.

▶ : Sealing locations

Spot Sealer: 3M #08892 (Internal)

: 3M #08893 (External)

Use materials above or equivalents.

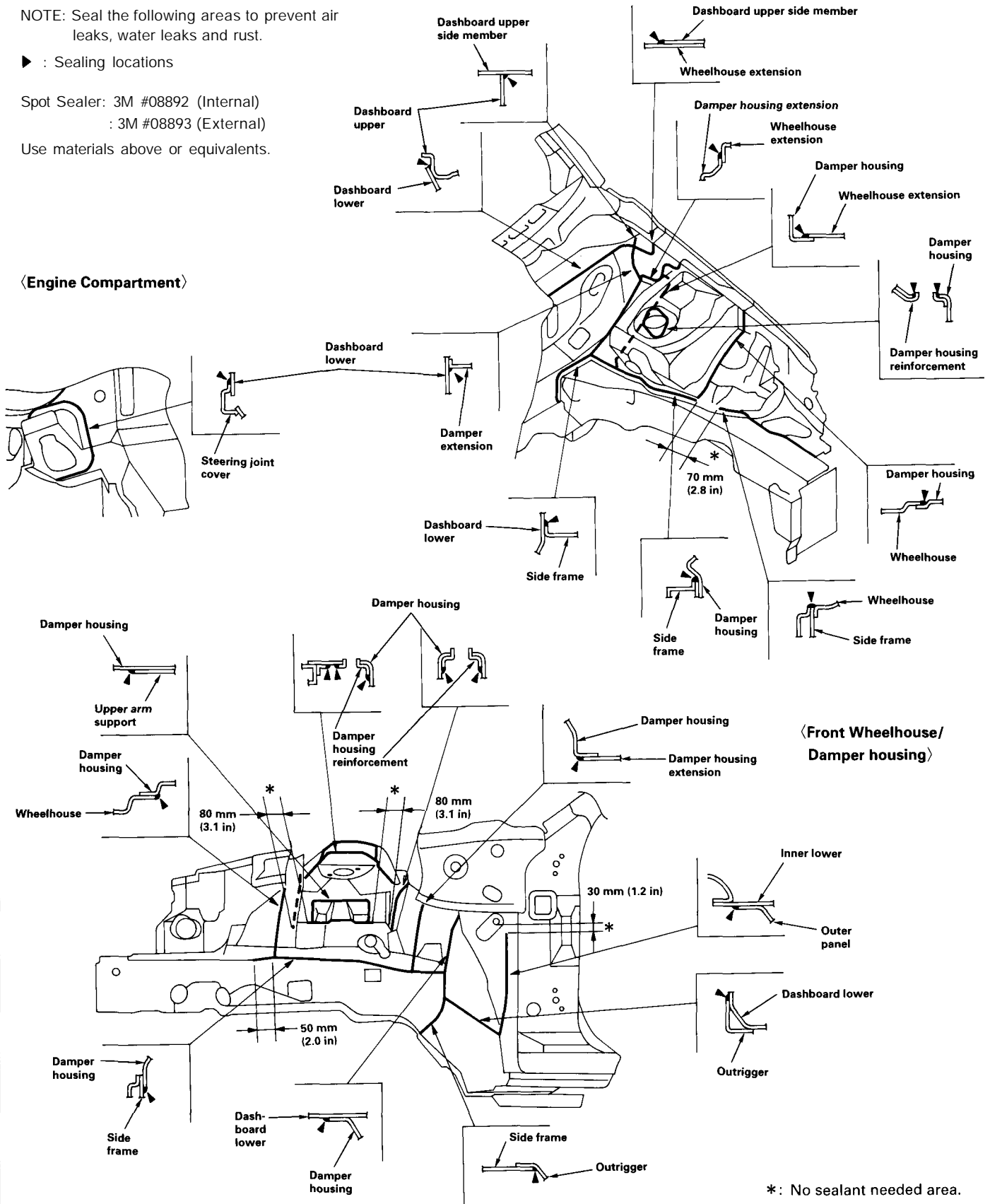

\*: No sealant needed area.

<Dashboard Upper>

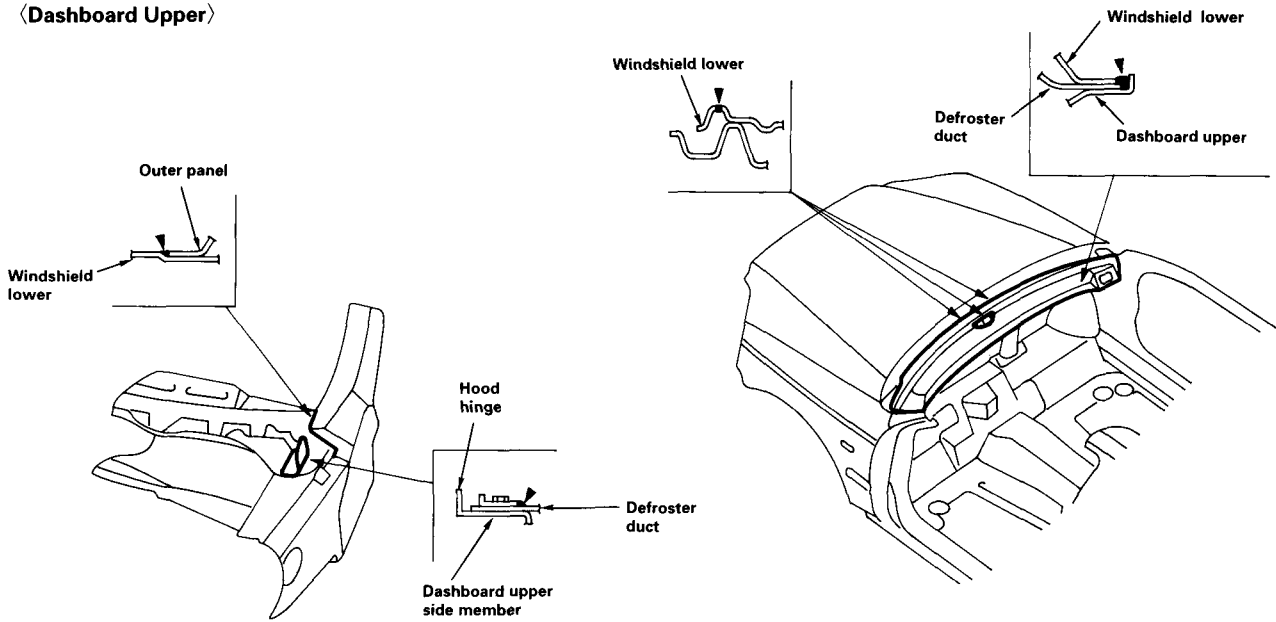

<Front Pillar Inner Panel>

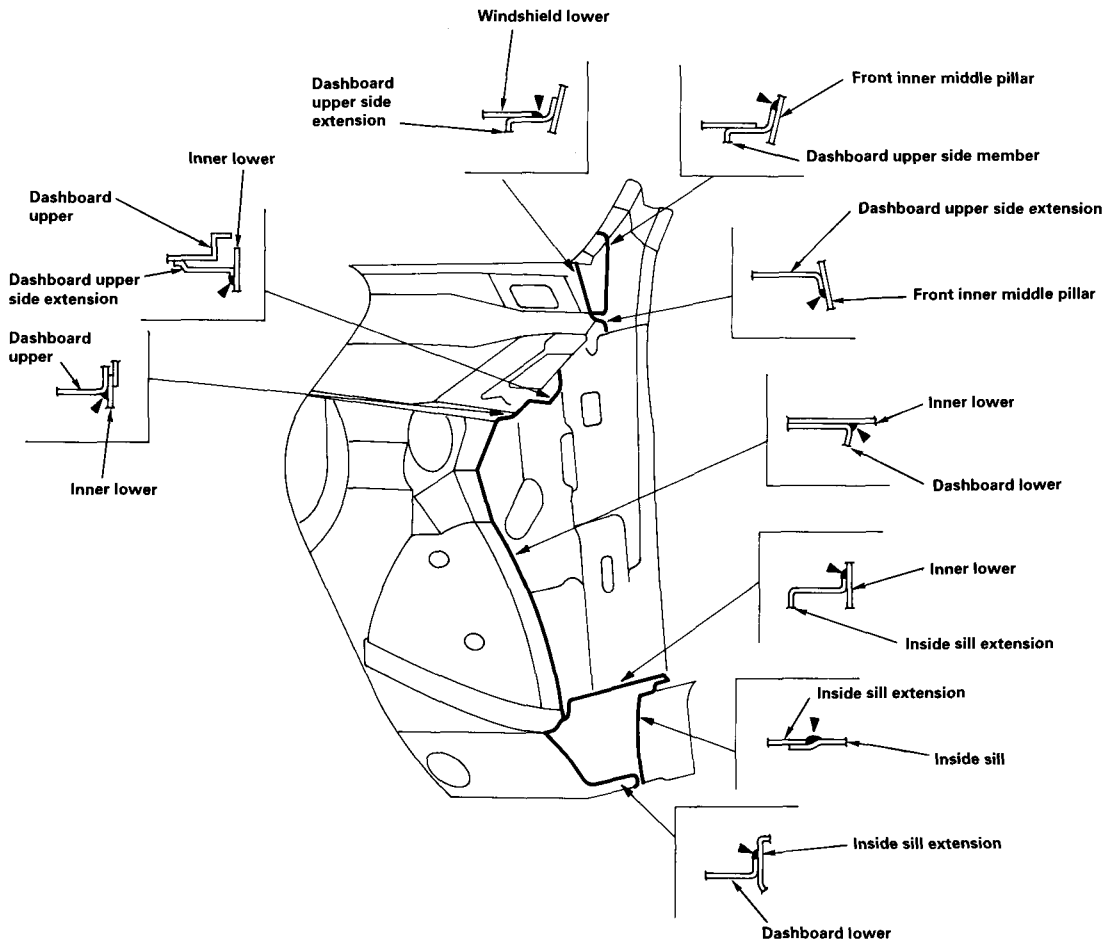

(cont'd)

# Cross Section of Body and Sealants

(cont'd)

〈Front Floor/Rear Floor〉

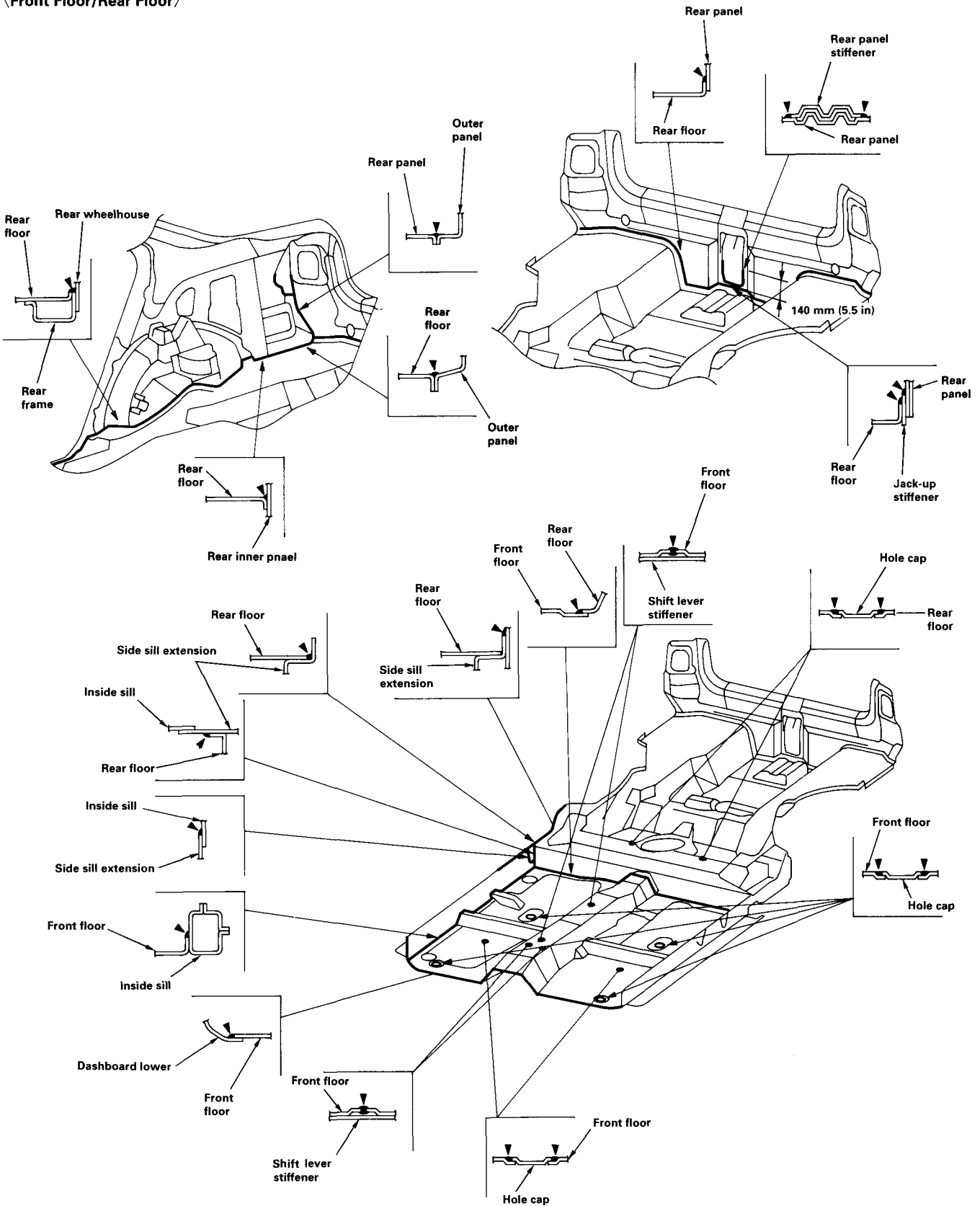

4-Door/2-Door:  
 (Rear Outer Panel, Rear Panel)

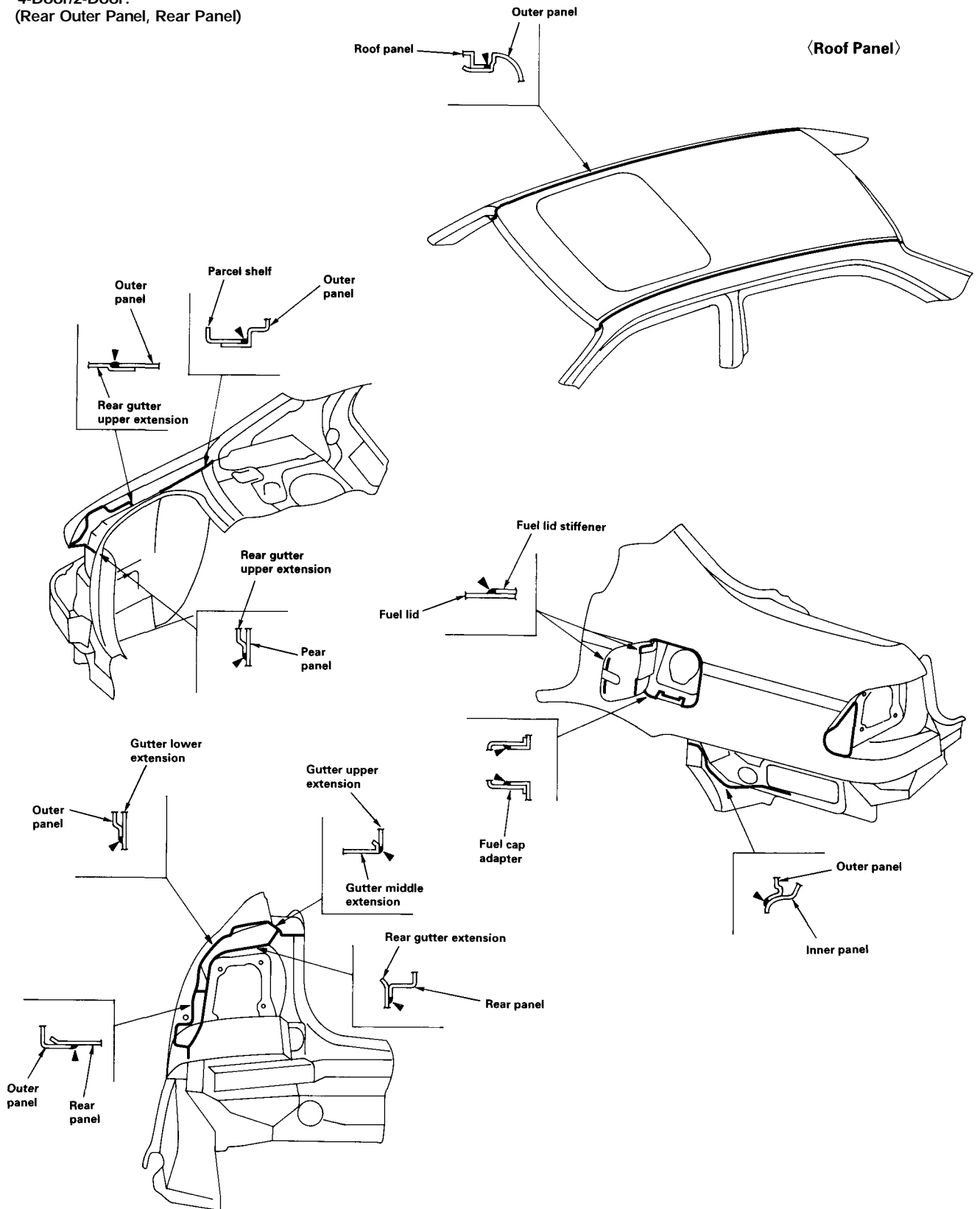

(cont'd)



# Cross Section of Body and Sealants

(cont'd)

3-Door:

(Rear Outer Panel, Rear Panel)

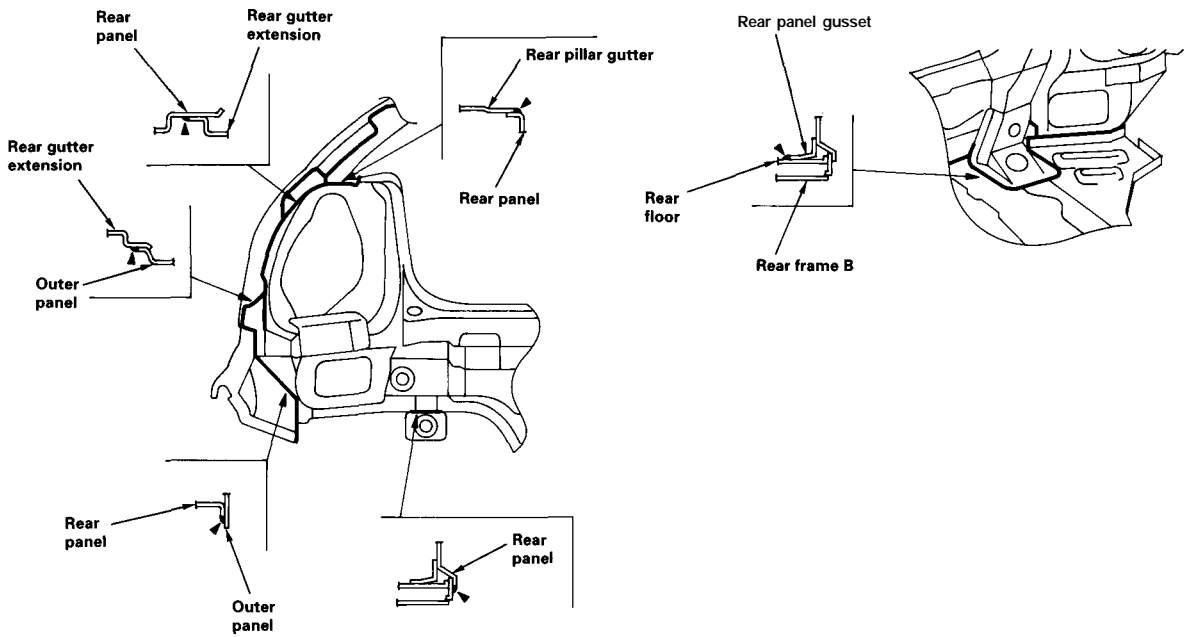
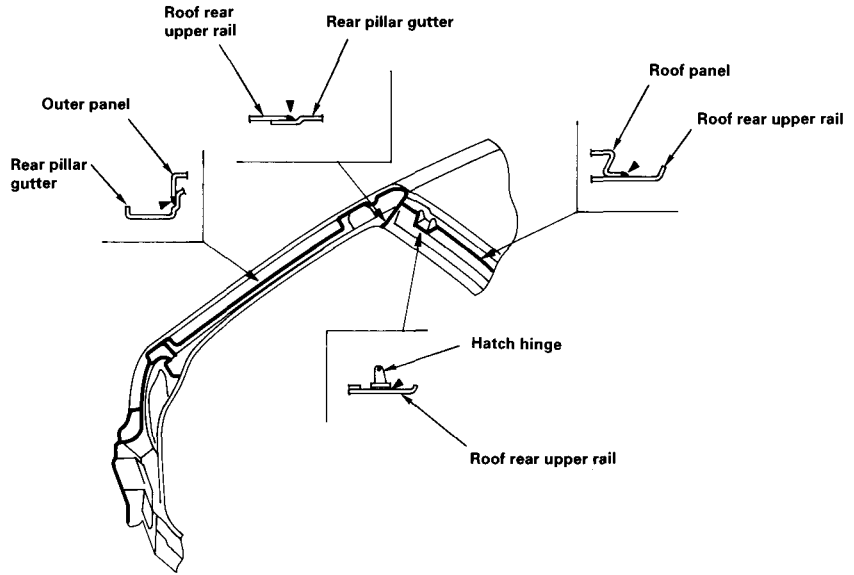

〈Rear Wheelhouse〉

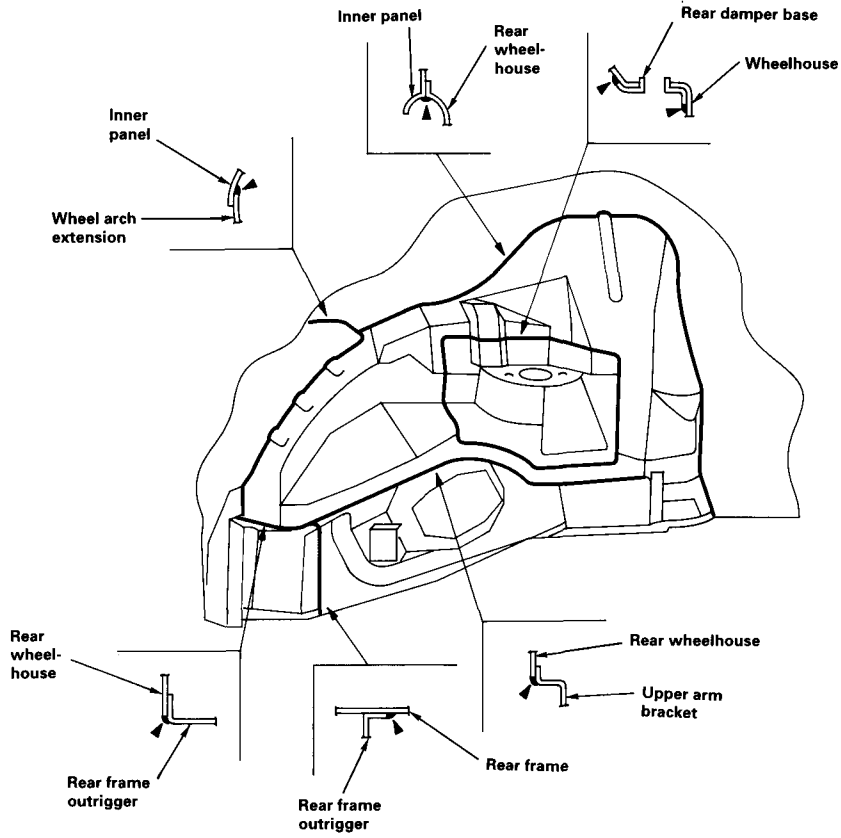

〈Under floor〉

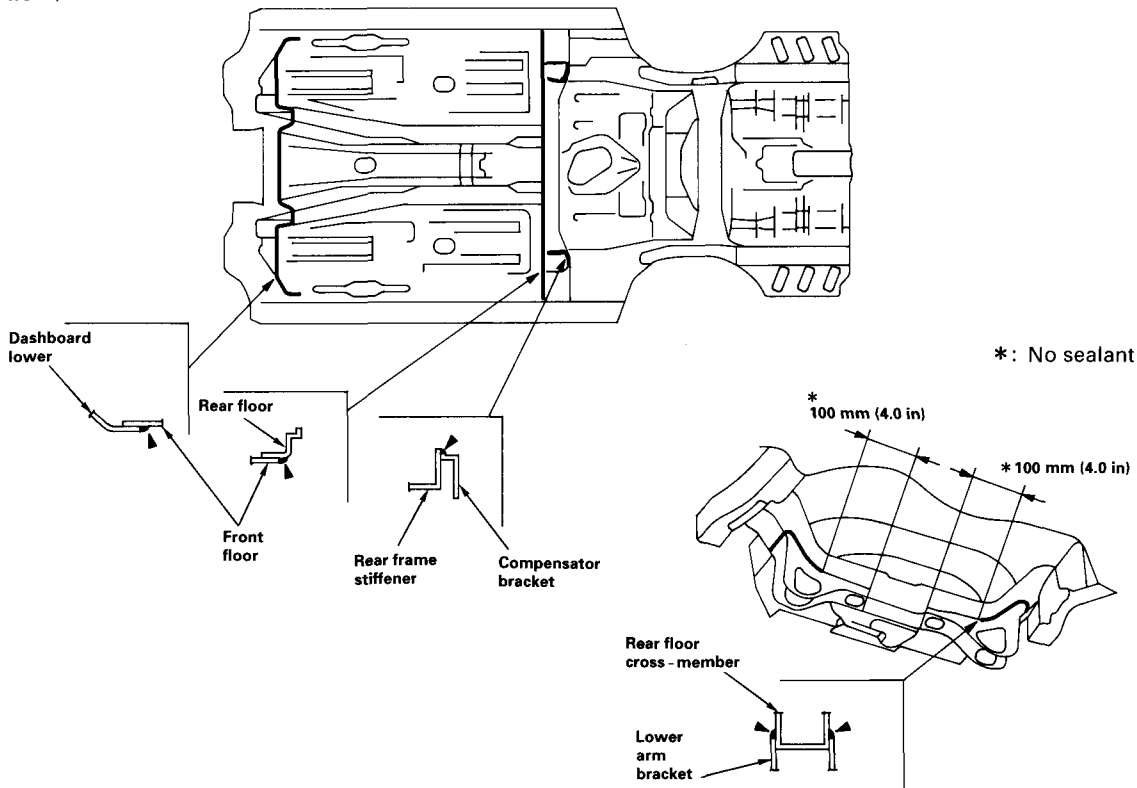

(cont'd)

# Cross Section of Body and Sealants

(cont'd)

## <Front Door>

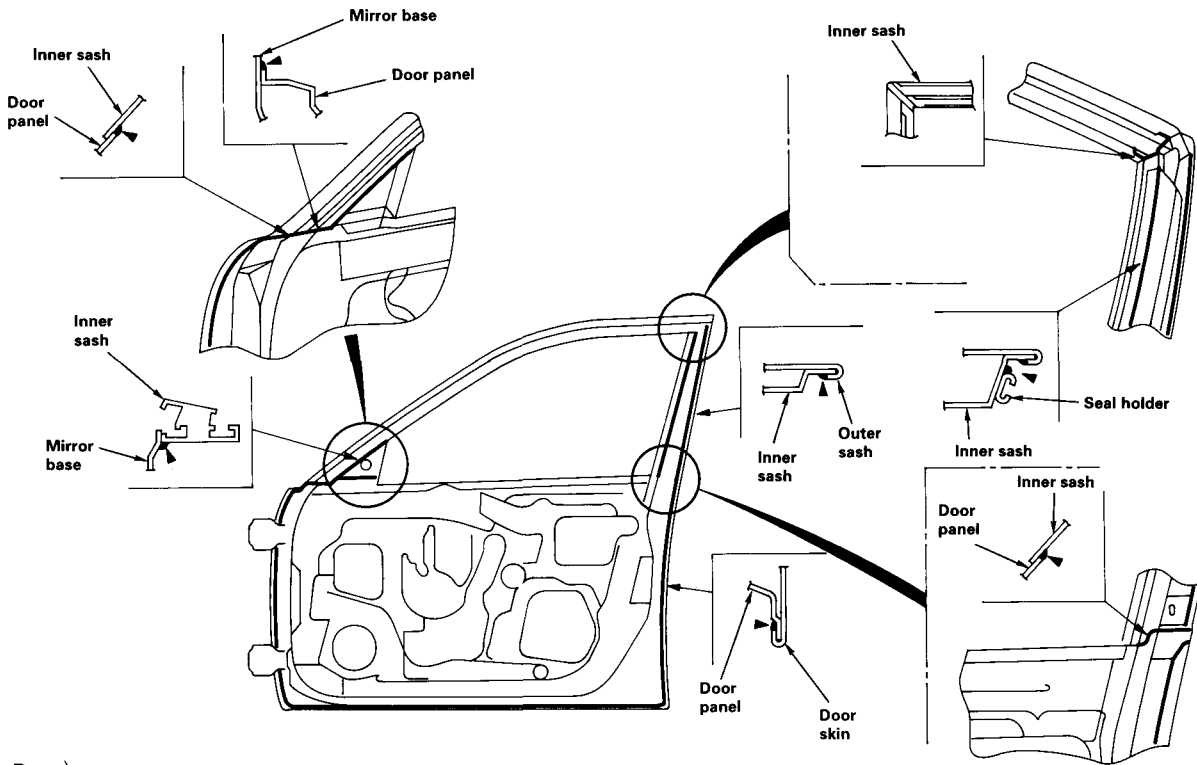

## <Rear Door>

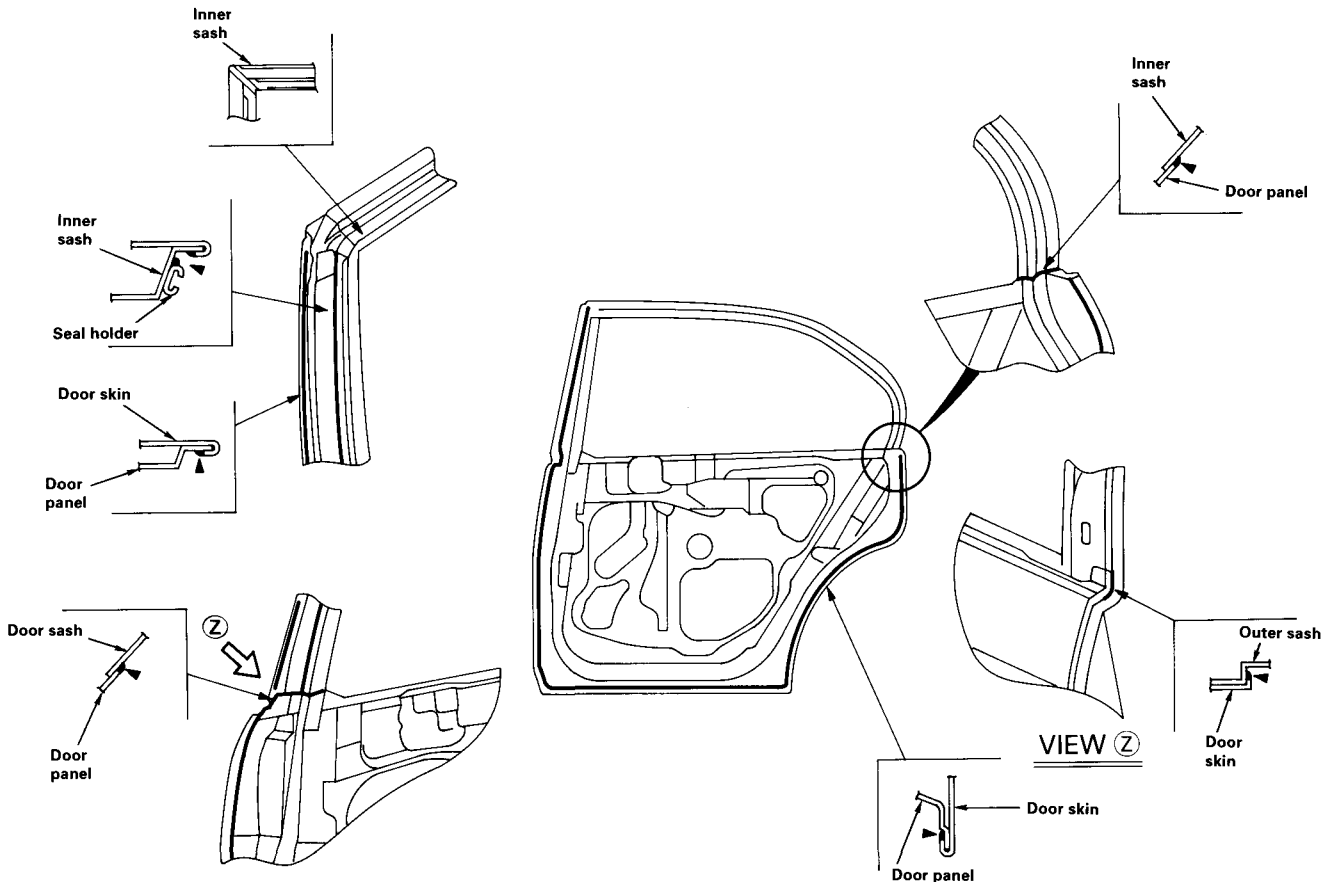

<Hood>

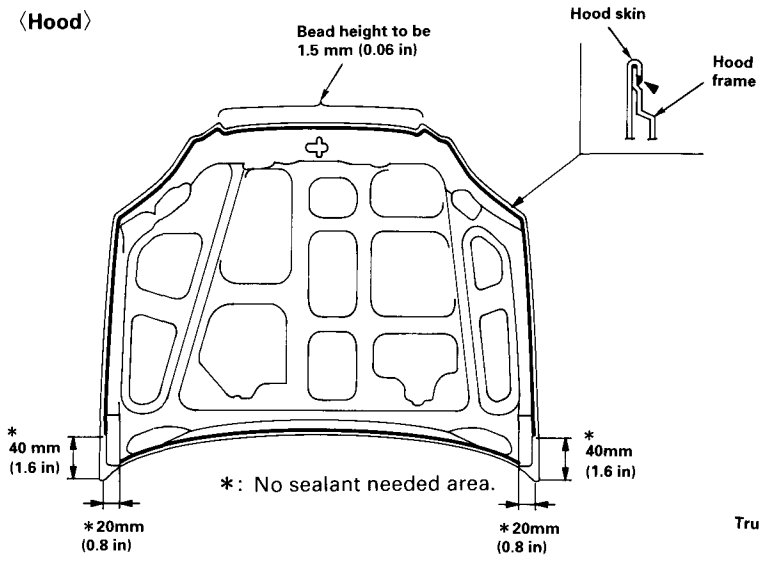

<Trunk Lid>

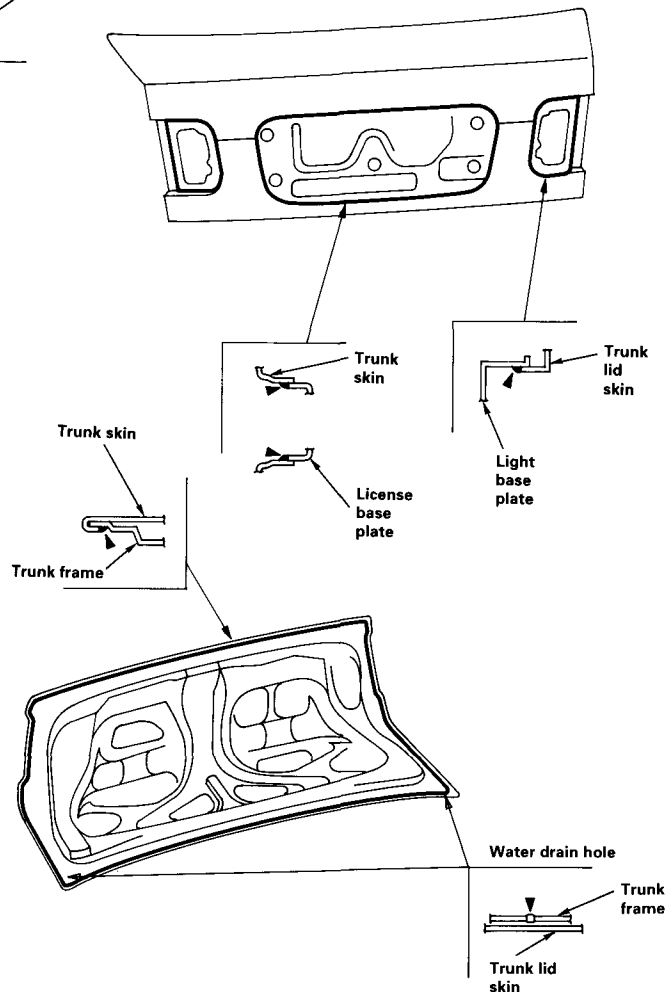

<Hatch>

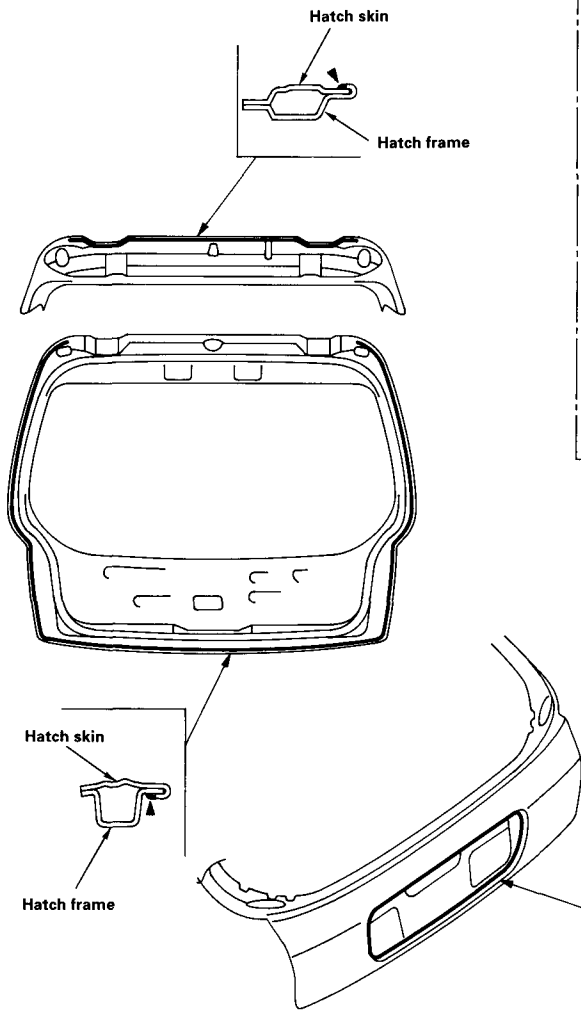

<Hatch Spoiler>

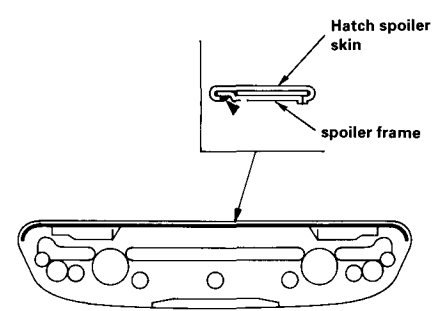

# Body Dimensional Drawings

<b>Upper Body Measuring Dimensions</b>	
<b>Engine Compartment</b> .....	<b>6-2</b>
<b>Passenger Compartment</b> .....	<b>6-3</b>
<b>Engine/Transmission Mounting Positions</b> .....	<b>6-3</b>
<b>Under Body Measuring Dimensions</b> .....	<b>6-4</b>
<b>Opening Repair Chart</b>	
<b>4-Door</b> .....	<b>6-5</b>
<b>3-Door</b> .....	<b>6-6</b>
<b>2-Door</b> .....	<b>6-7</b>
<b>Frame Repair Chart</b> .....	<b>6-8</b>

# Body Dimensional Drawings

## Upper Body Measuring Dimensions

### Engine Compartment

Unit: mm (in)

NOTE: Measuring dimensions show the distance between the forward or upper edge of positioning bosses and/or holes shown in the detail sketches.

Measuring point (Black dots)

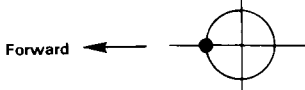

F: Forward  
C: Center

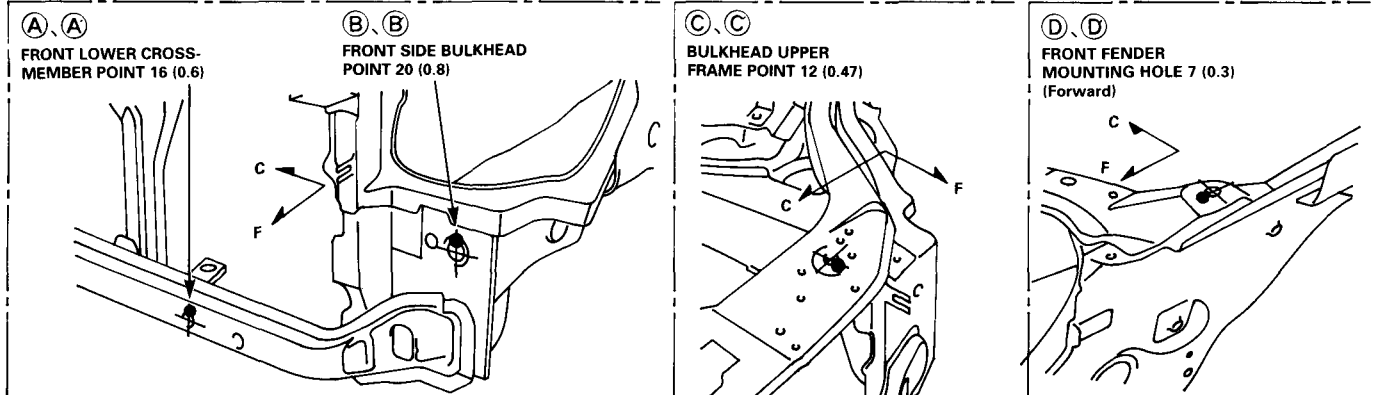
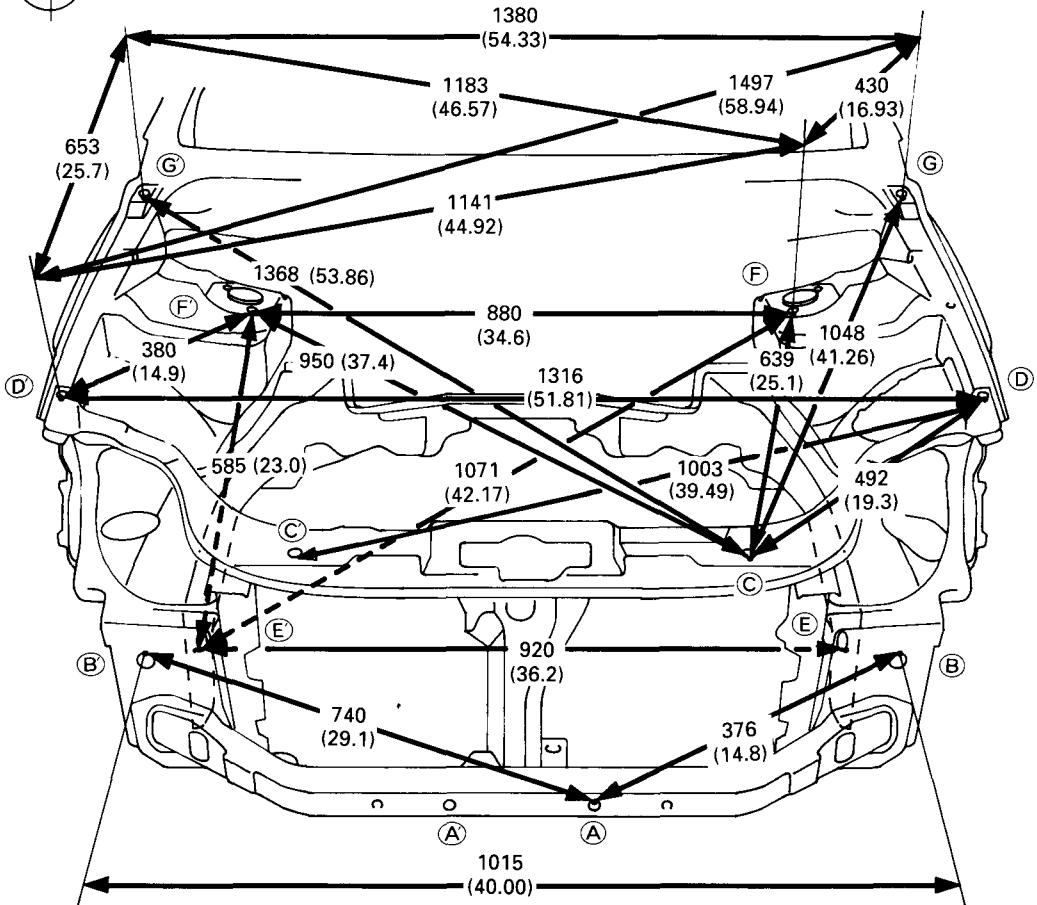
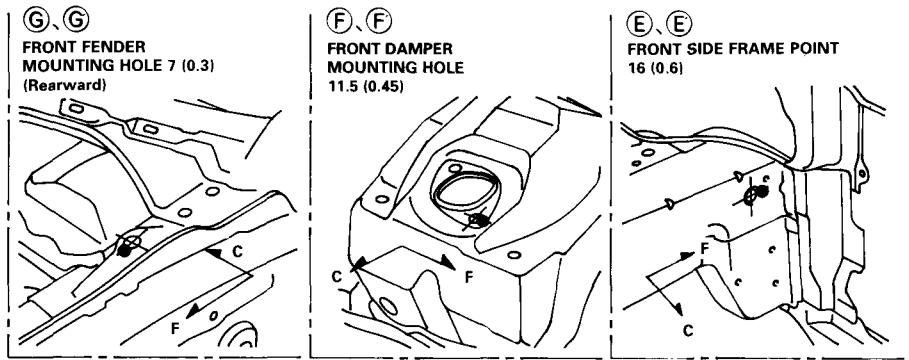

<Passenger Compartment>

Unit: mm(in)

①、①  
REAR DAMPER  
MOUNTING HOLE 11.5 (0.45)

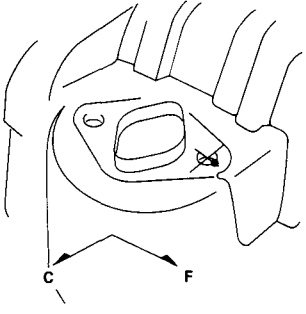

Ⓜ、Ⓜ  
FRONT SEAT REAR  
SIDE BRACKET 8 (0.3)

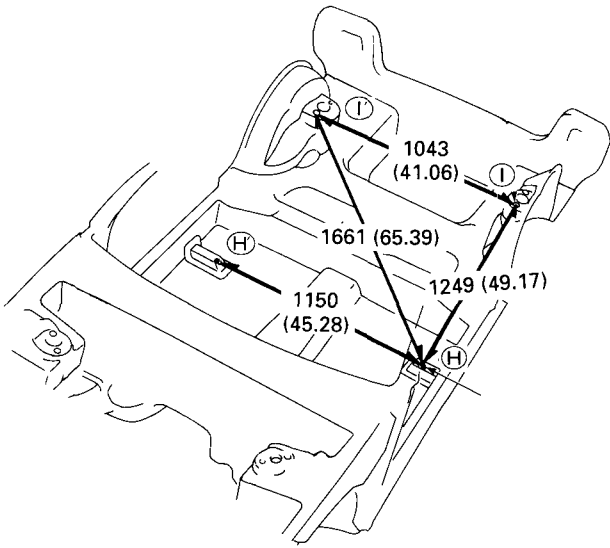
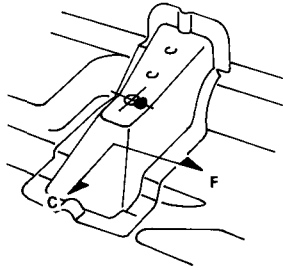

# Engine/Transmission Mounting Positions

Unit: mm (in)

F: Forward

C: Center

Measuring point  
(Black dots)

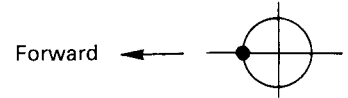

**(A)**  
CVT TRANSMISSION  
MOUNT BRACKET POINT  
11 (0.43)

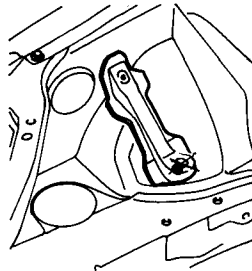

**(E)**  
A/T-M/T TRANSMISSION  
MOUNT BRACKET POINT  
13 (0.51)

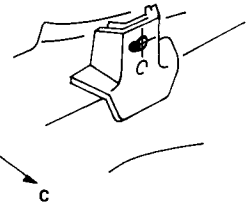

**(B)**  
ENGINE SIDE MOUNT  
BRACKET POINT 13 (0.51)

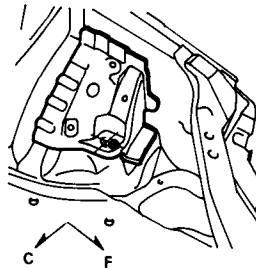

**(C, D)**  
FRONT SIDE FRAME POINT  
16 (0.6)

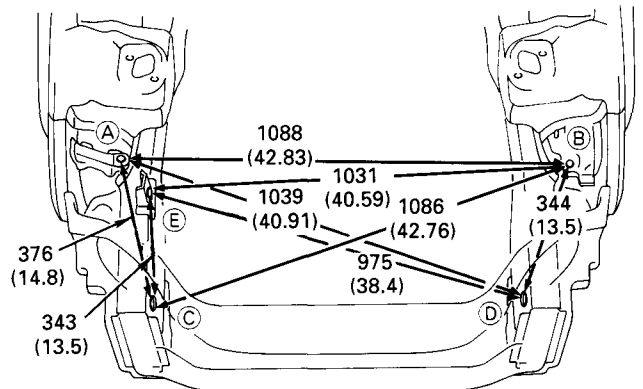
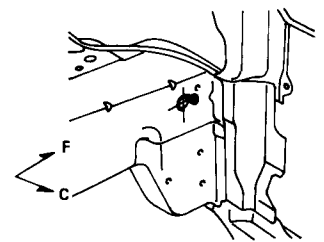



# Body Dimensional Drawings

## Under Body Measuring Dimensions

Unit: mm (in)

F: Forward  
C: Center

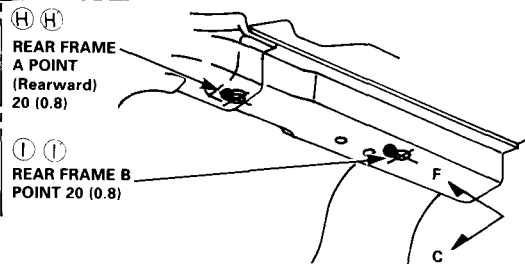
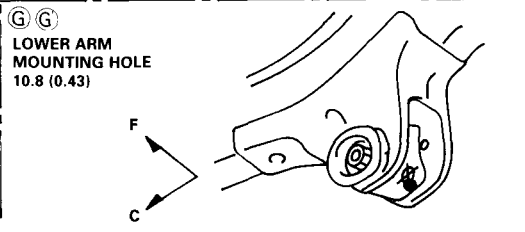
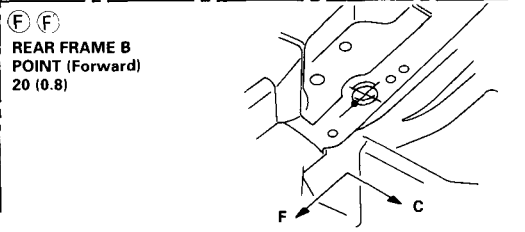
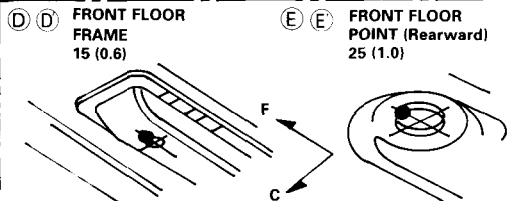
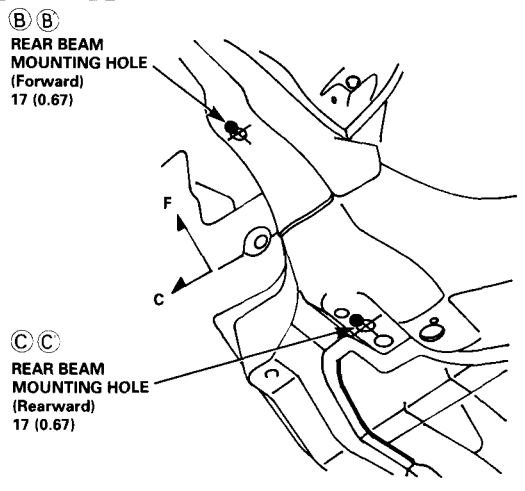
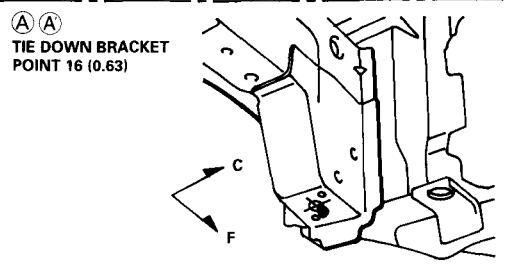
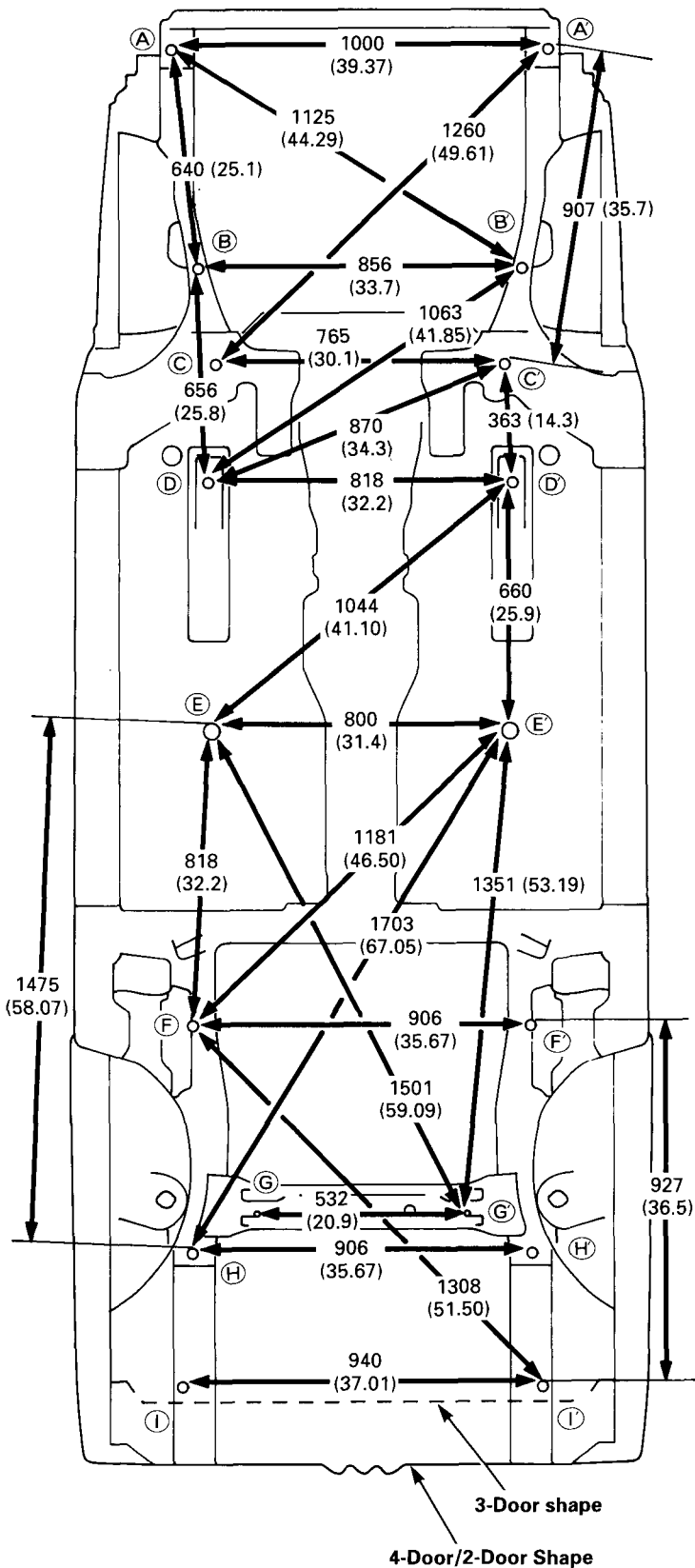

# Opening Repair Chart (4-Door)

Unit: mm (in)

## <Windshield/Doors Opening>

**A** Dashboard upper cowl cover mounting hole

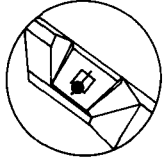

**B, C** Windshield opening flange notch (3 places)

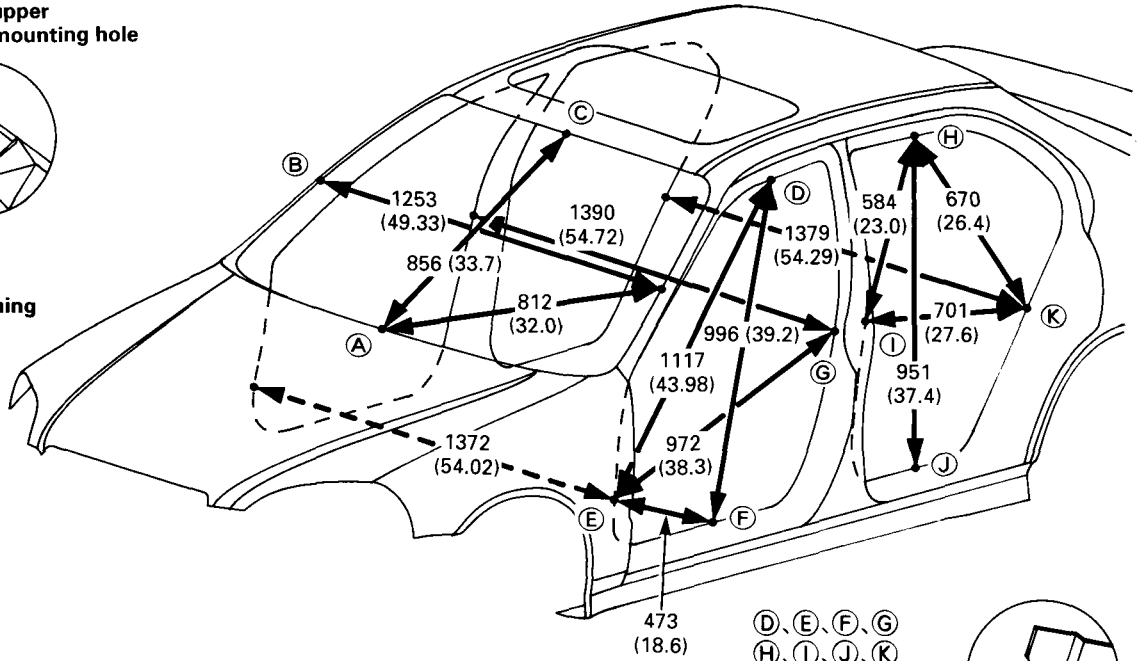
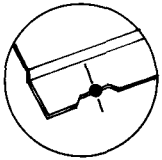

**D, E, F, G**  
**H, I, J, K**

Door opening area flange notch (8 places)

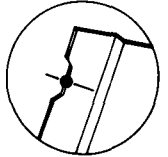

## <Trunk Lid/Rear Window Opening>

**L** Roof panel flange notch

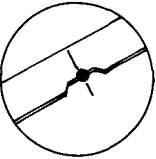

**M** Outer panel flange notch (2 places)

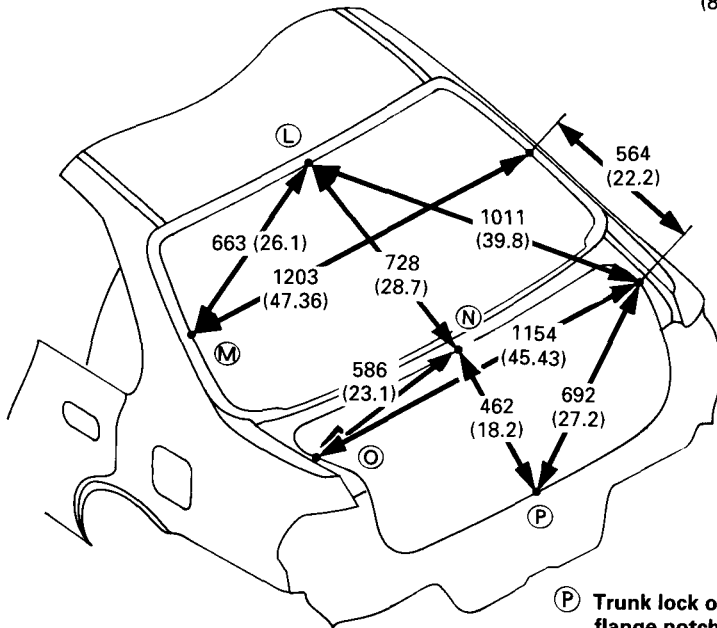
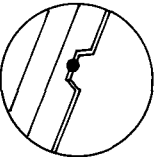

**N** Trunk gutter area convex bead

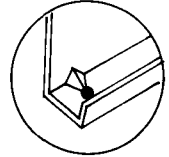

**O** Outer panel flange end (2 Places)

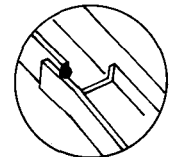

**P** Trunk lock opening flange notch

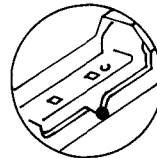

# Body Dimensional Drawings

## Opening Repair Chart (3-Door)

Unit: mm (in)

### 〈Windshield/Doors Opening〉

**A** Dashboard upper cowl cover mounting hole

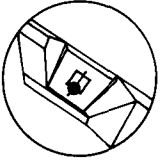

**B, C** Windshield opening flange notch (3 places)

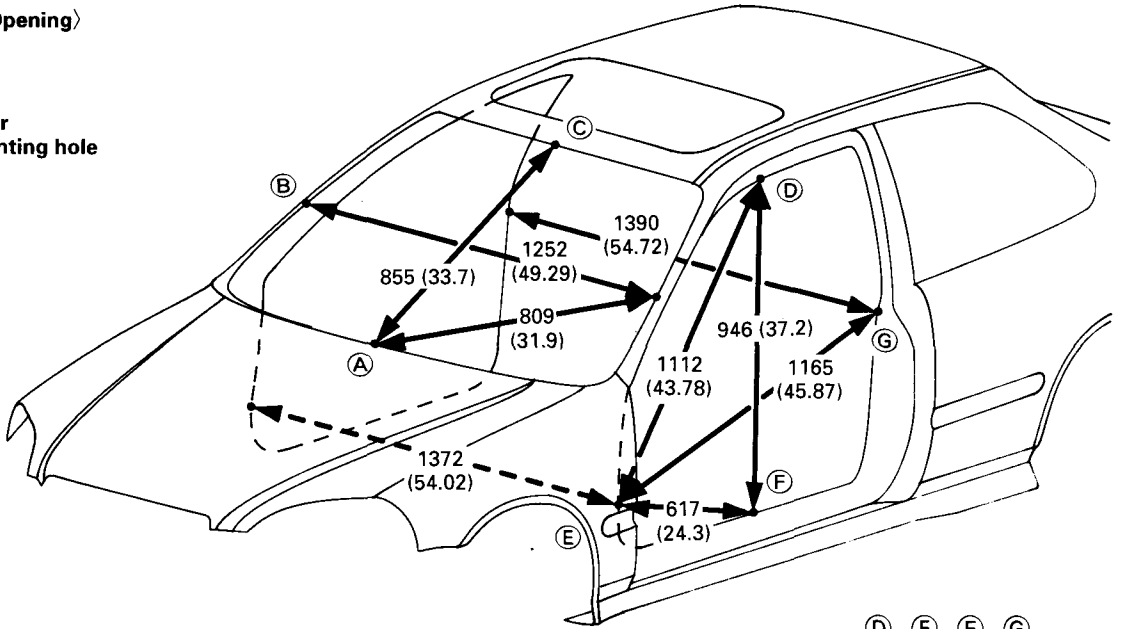
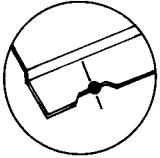

**D, E, F, G** Door opening area flange notch (4 places)

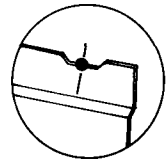

### 〈Hatch Opening〉

**H** Rear lower rail flange notch

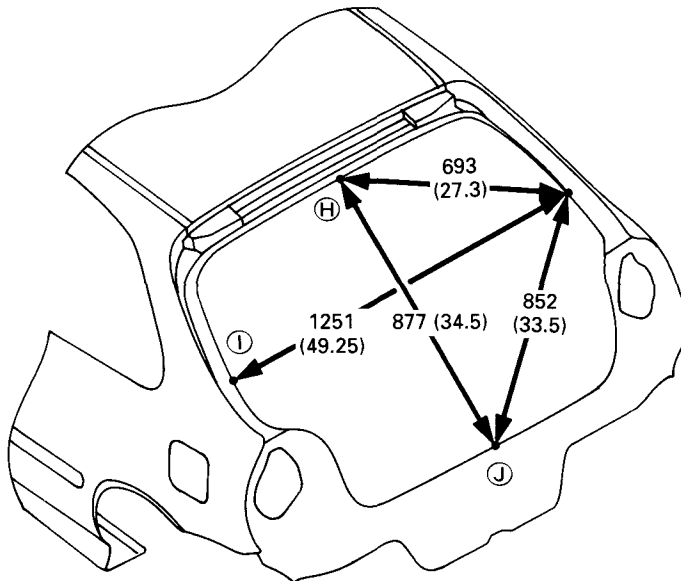
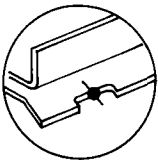

**I** Rear pillar gutter depression bead (2 places)

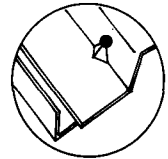

**J** Hatch striker support notch

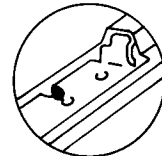

# Opening Repair Chart (2-Door)

Unit: mm (in)

## 〈Windshield/Doors Opening〉

**(A)** Dashboard upper cowl cover mounting hole

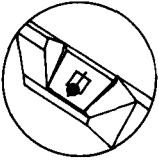

**(B), (C)** Windshield opening flange notch (3 places)

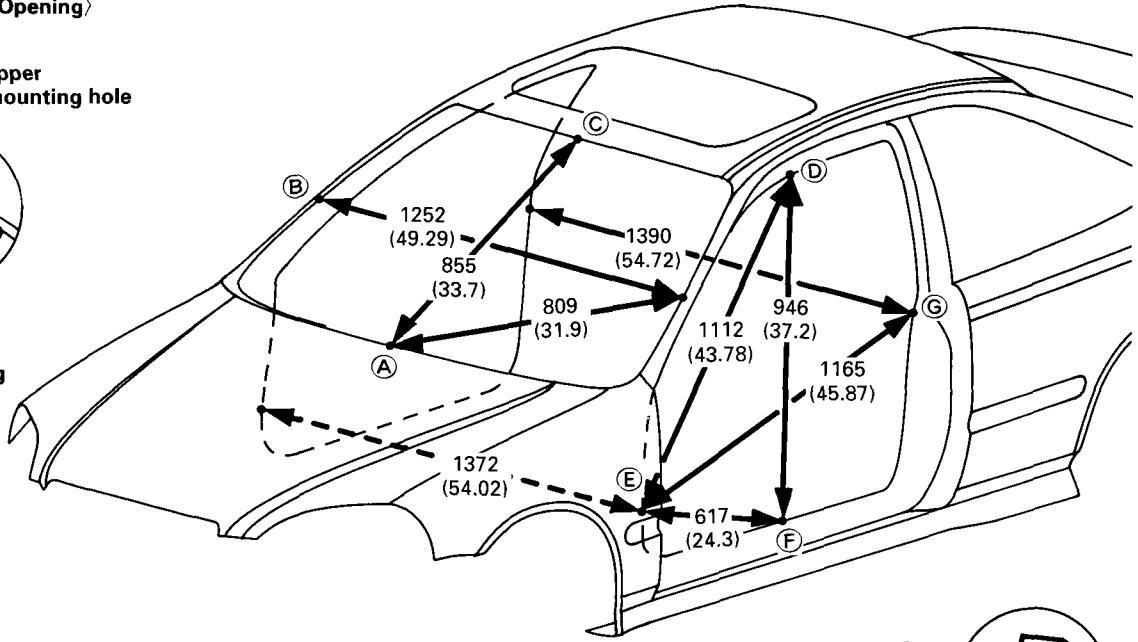
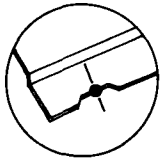

**(D), (E), (F), (G)** Door opening area flange notch (4 places)

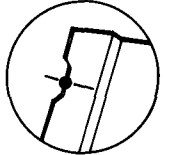

## 〈Trunk Lid/Rear Window Opening〉

**(H)** Roof panel flange notch

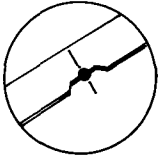

**(J)** Trunk gutter area convex bead

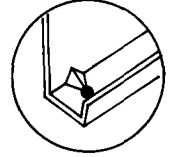

**(I)** Outer panel flange notch (2 places)

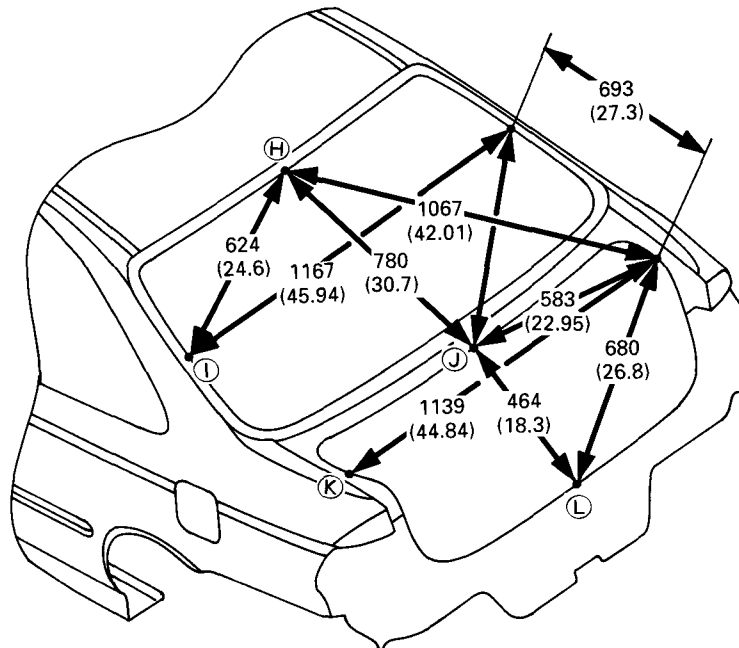
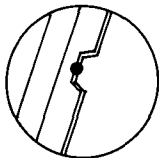

**(K)** Outer panel flange end (2 places)

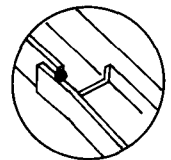

**(L)** Trunk lock opening flange notch

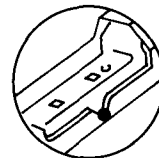

# Body Dimensional Drawings

## Frame Repair Chart

Unit: mm (in)  
 ø: Inner diameter

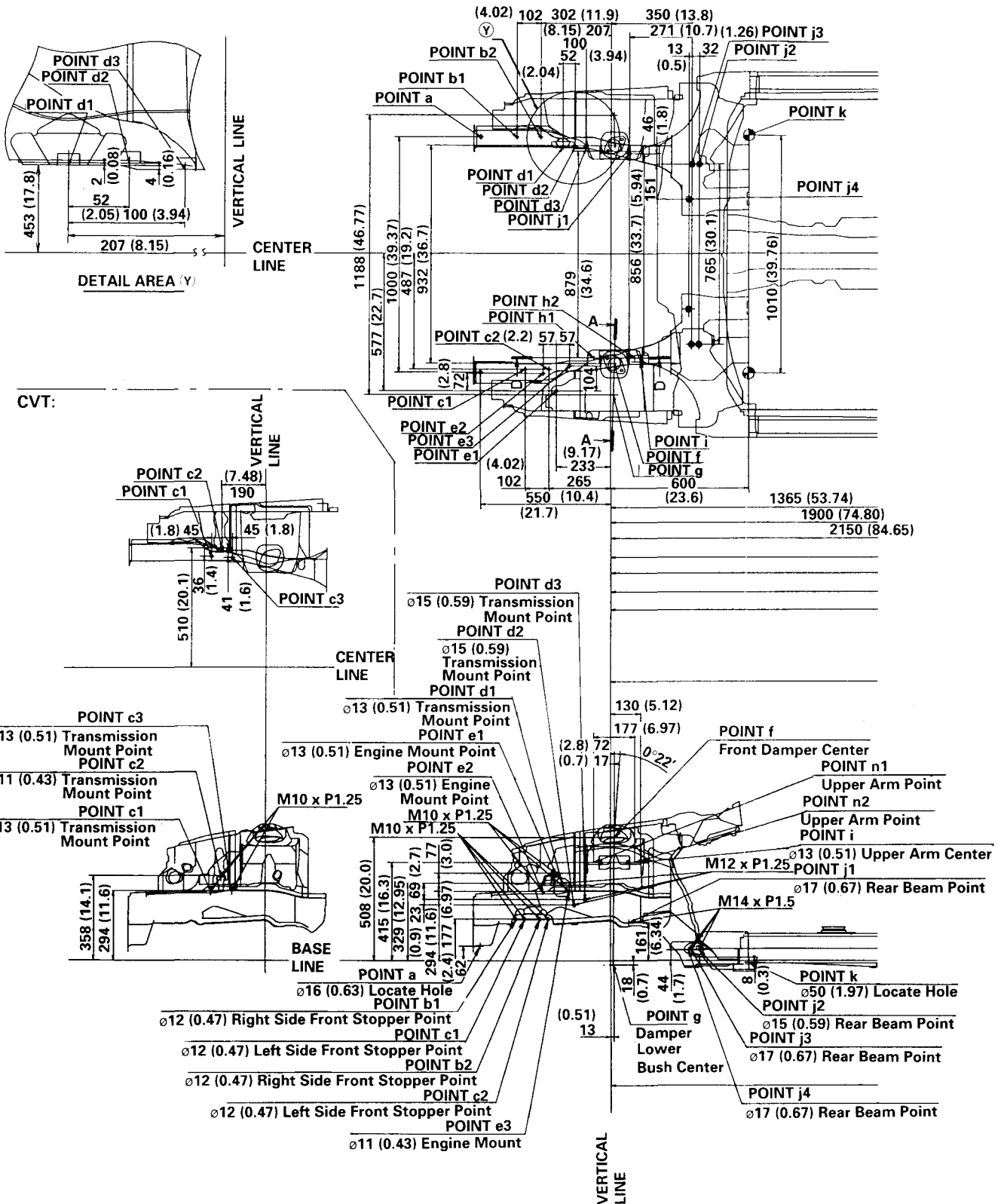

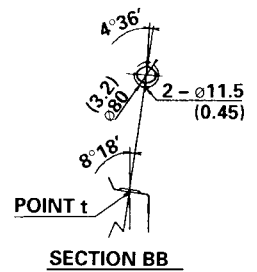
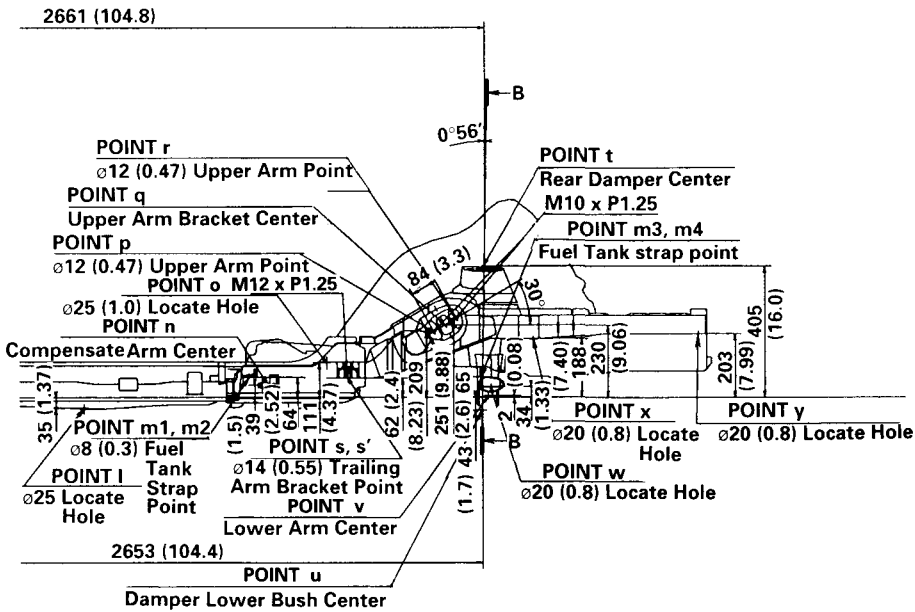
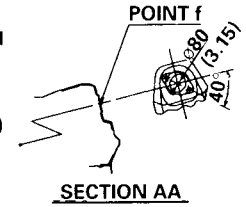
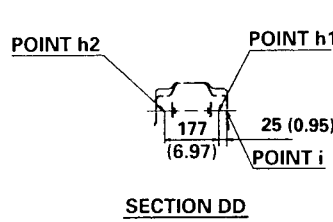
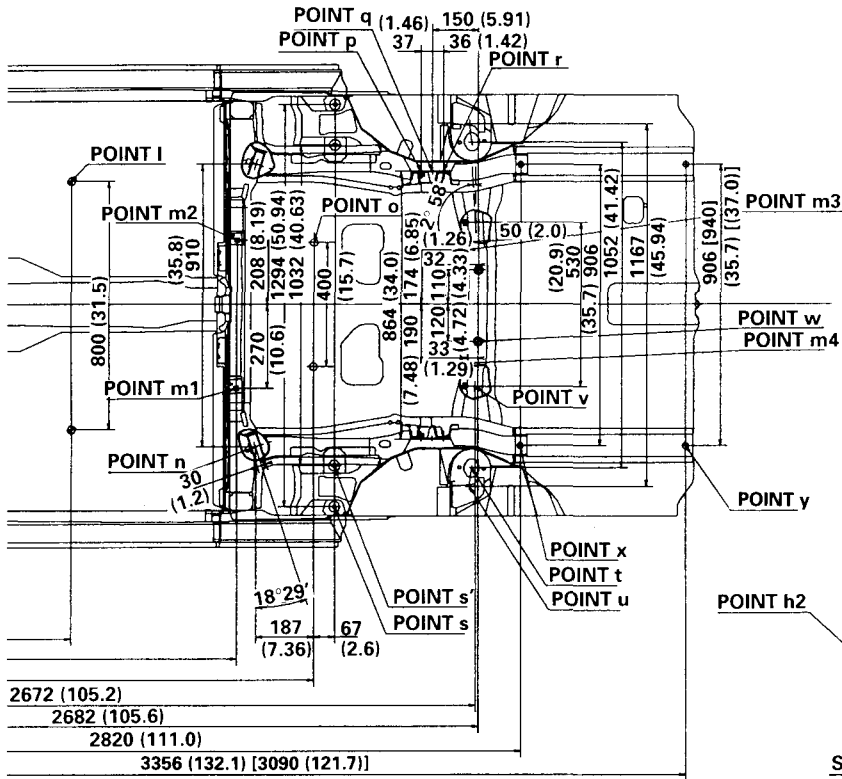

# Rust-preventive Treatments

- General ..... 7-2
- Diagram ..... 7-3
- Area to be Covered by Anti-rust Agents ..... 7-4
- Undercoating Diagram ..... 7-10

# Rust-preventive Treatments

## General

Corrosion starts immediately after the steel base contacts the atmosphere. The condition is aggravated by sea wind, road salt, rain, snow and industrial fallout. There are many ways to protect automobiles against corrosion. Primers, primer surfacers and paints are applied by electrodeposition or spray to protect the car body.

### Anti-rust Agents and Spray Guns

Use the following anti-rust agents or equivalents when making a body repair.

**▲ WARNING** ANTI-RUST agents contain substances that are harmful if you breathe or swallow them, or get them on your skin. Wear coveralls, gloves, eye protection, and an approved respirator while using such agents.









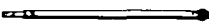
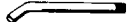

#### Anti-rust agents:

RUSTOP DEOX # 100 WAXOYL or equivalent	To be applied to welded joints inside body panel.	USA MARKET AUTO ARMOR 1031 (made by ECP)
NOX-RUST 409-20S SOLTON 1000S or equivalent	To be applied to under-floor and wheelhouse	AUTO ARMOR OUTSIDE COATING (made by ECP)

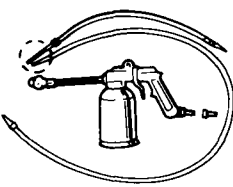
#### Spray guns:

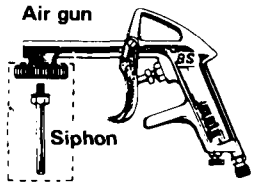
Use the correct gun for the agent being used.

- Use of a pressure type spray gun is recommended when work involves a considerable number of cars.

For RUSTOP	For DEOX#100	For WAXOYL	For NOXRUST 409-20S/ SOLTON 1000S
 <b>Flexible nozzle</b>  <b>Open nozzle</b> 	 <b>L-type nozzle</b>  <b>360° nozzle</b> 	 <b>L-type nozzle</b>  <b>360° nozzle</b> 	<b>Air gun</b>  <b>Siphon</b>  <b>V-type nozzle</b>  <b>Open nozzle</b> 
Protectors: Wear gloves, mask and suitable eye protection. »Use light oil and a rag to clean up spilled anti-rust agents.			

#### Precautions:

1. Before applying an anti-rust agent, thoroughly clean the areas to be coated with a steam cleaner, etc., and let dry.

NOTE: Waxoyl may be applied to wet surface.

2. Spray an anti-rust agent sufficiently until the excess amount oozes out when filling, the doors, side sills, etc.  
Wipe the excess agent with a clean rag dampened with light oil.
3. Do not spray an anti-rust agent to the brake hoses, brake wheel cylinders, brake drums, exhaust muffler and its related parts, emission control devices in the engine compartment, ball joint covers, plastic fuel strainer, etc.  
Wipe up spilled agent at once.
4. Heat an anti-rust agent to room temperature 97.7°F (36.5°C) by submerging the container in hot water when outside temperature is below 50°F (10°C).
5. Ventilate when spraying an anti-rust agent since it contains a small amount of organic solvent. Keep sparks, flames and cigarettes away.  
Clean the spray gun after spraying with anti-rust agent.

**CAUTION:** Any remaining agent will harden in the passages of the spray gun, making it unserviceable.



# Diagram

**NOTE:**

- Apply the designated thickness over surfaces including gaps and edges.
- Avoid spraying agents on following parts:  
Window glass, lights, grille, exhaust parts, tires, bumper and lower skirt.
- Wipe up spilled agents at once from rubber and plastic parts.

**Anti-rust Agents:**

- Use RUSTOP, DEOX #100, WAXOYL or equivalents for protecting inner surfaces.
- Use NOX-RUST 409-20S, SOLTON 1000S or equivalents for protecting outer surfaces.

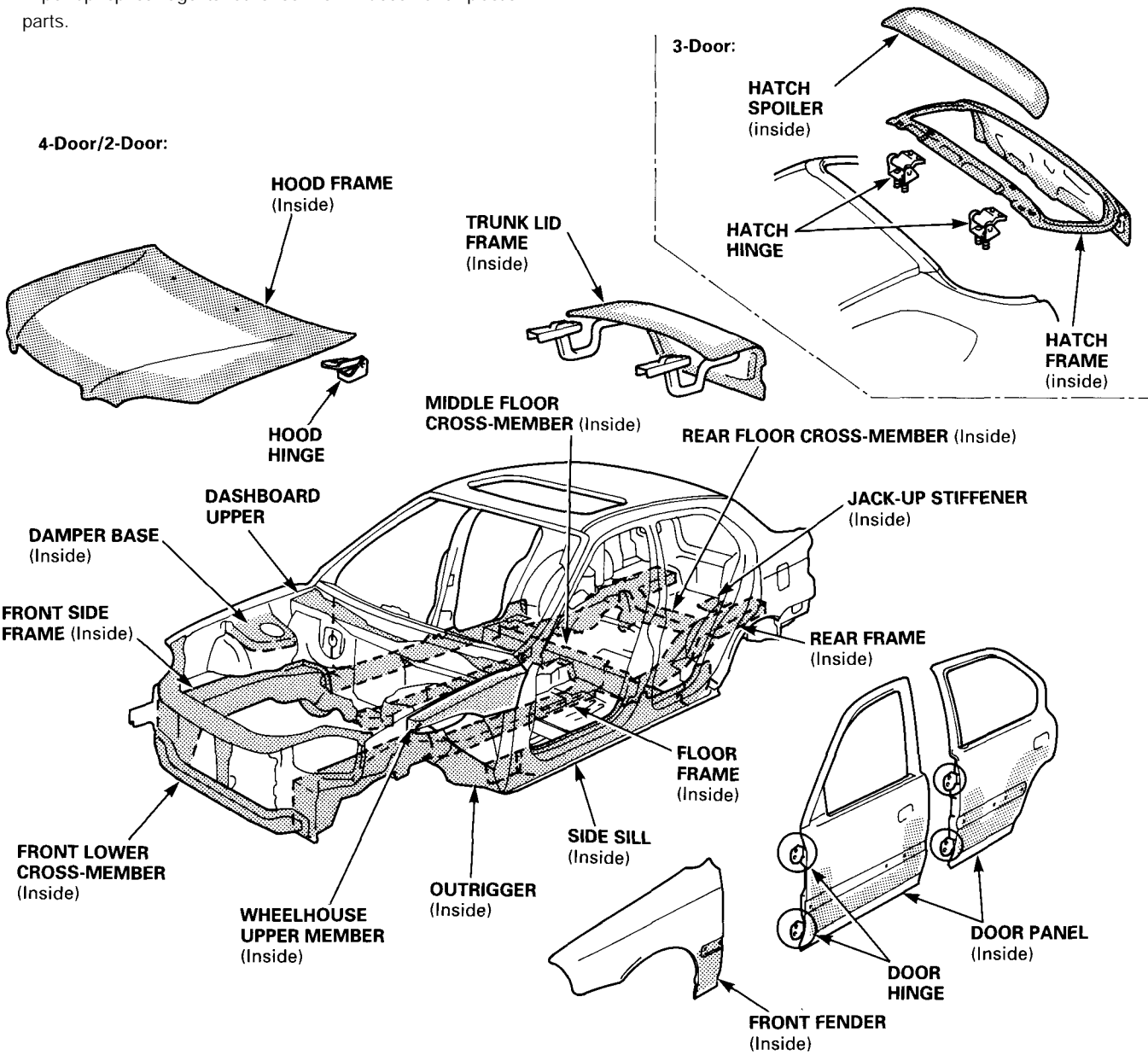

<Whole underside of floor>

NOTE: Do not apply to the exhaust system, brake disc and engine belts.

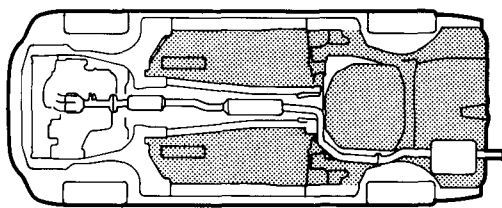

# Rust-preventive Treatments

## Areas to be Covered by Anti-rust Agents

### Rust-preventive Treatments:

Nozzle	Type
A	360°
B	L-type
C	Straight nozzle (undercoat gun)

### Hood, Underside

- Coat the entire panel and seams all the way around.
- Spray sufficient anti-rust agent to the front area and each corner.
- Apply rust-preventive agent or grease to the hood hinges.
- Also coat the bulkhead upper frame and hood frame with anti-rust agent.

Nozzles used: A and B

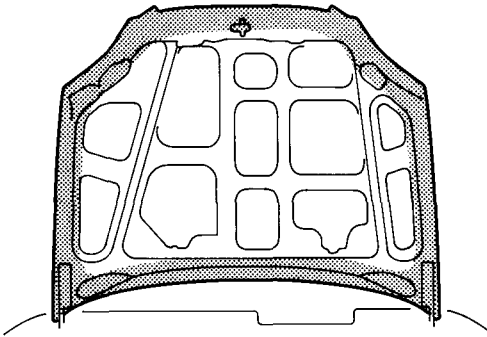

### Dashboard Upper/Windshield Lower

- Coat the windshield lower and dashboard upper water drain with anti-rust agent at front, right and left.
- Spray anti-rust agent completely over the rear of the dashboard upper (windshield side).

NOTE: To insert the nozzle in the dashboard upper, remove the air scoop grille for easier, more thorough spraying.

Nozzles used: A and B

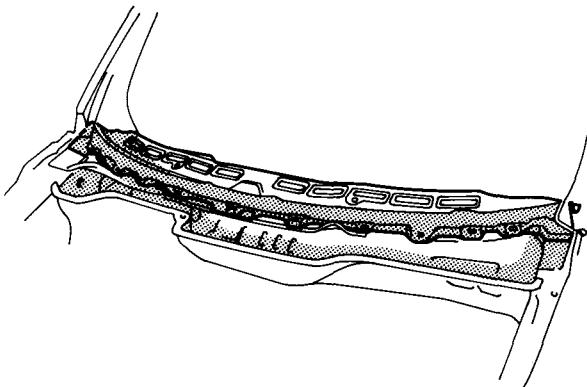

### Front Bulkhead Area

With the hood opened, coat the joints of the bulkhead, wheelhouse and side frame and around the back of the headlight assembly.

Nozzle used: B

### BULKHEAD UPPER FRAME

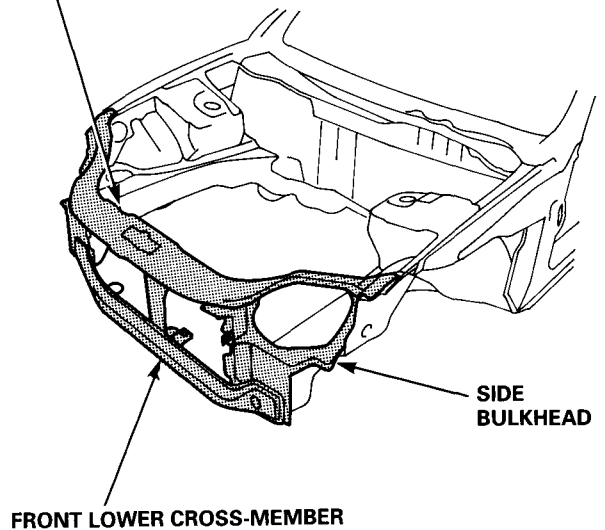

### Bulkhead, Back

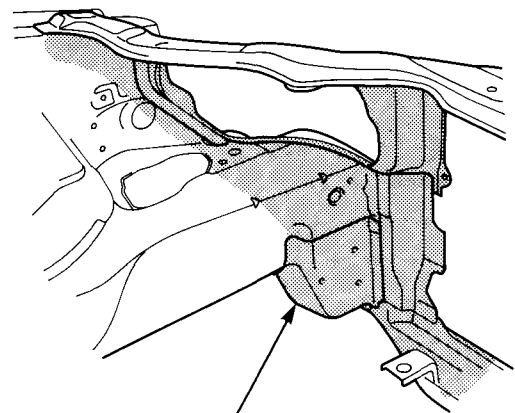

Spray the inside of the tie down bracket.

Nozzles used: A and B

### Front Fender, Underside

Apply anti-rust agent to the end of the fender, wheelhouse, and side sill installation.

#### NOTE:

- Remove the inner fender, then apply a coat of agent to the front door side, wheel arch end.
- If the fender is to be removed, care take to avoid damaging the paint finish. Apply agent to the entire surface of the back of the fender.
- Apply agent to the front fender filling pillar.

Nozzle used: B

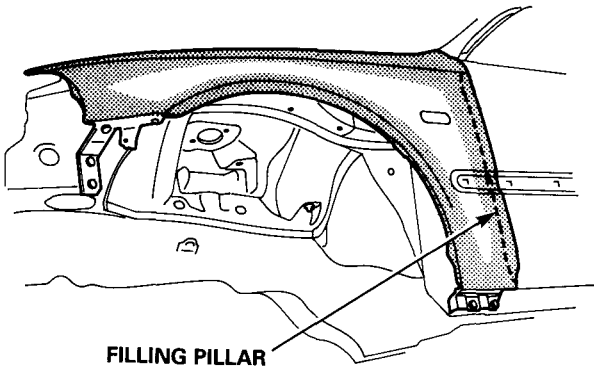

### Wheelhouse Upper Member, Inside

- Remove the front fender and grommets.
- Remove the air scoop grille in the dashboard upper and coat the inside of the wheelhouse upper member with anti-rust agent.

Nozzles used: A and B

### WHEELHOUSE UPPER MEMBER

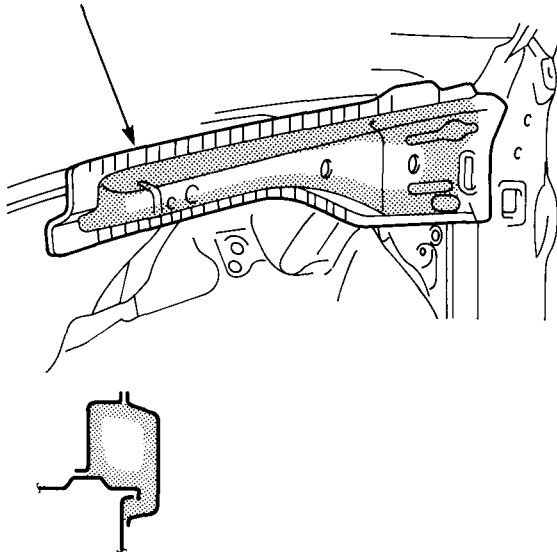

### Outside Panel (Front Pillar and Center Pillar), Inside

- Remove the door harness grommet and insert the nozzle facing down.

NOTE: Make sure that the nozzle is not interfering with the door hinge bracket. Spray thoroughly.

- Coat the door checker bracket.

### Doors, Inside

- Apply agent to the joint between the door stiffener and door skin through the water drain hole at the bottom of the door.
- If necessary, remove the door side molding and weather-strip, then spray the agent through the hole.

NOTE: When a suction type spray gun is used, remove the door trim panel.

Nozzles used: A and B

#### <Front>

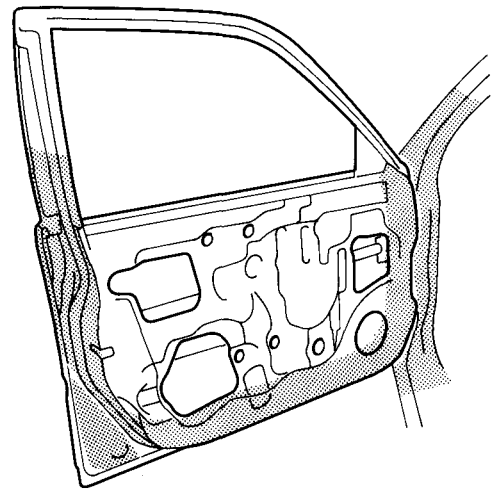

#### <Rear>

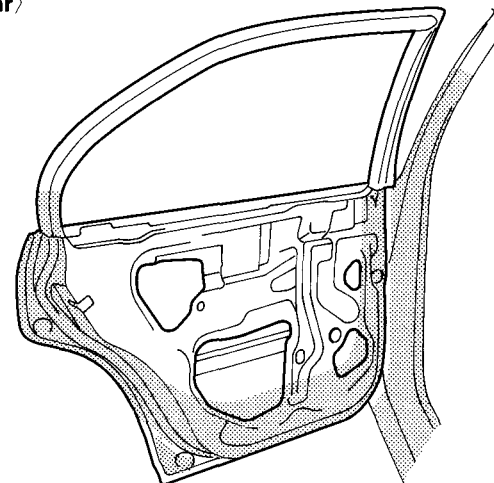

(cont'd)

# Rust-preventive Treatments

## Areas to be Covered by Anti-rust Agents (cont'd)

### Rear Side Outer Panel, Inside

- Remove the door lock striker, taillight and grommets, then spray agent through the hole.
- Also spray agent on the back of the fuel fill lid.
- To apply agent to the inside of the rear wheelhouse, remove rear trim panel and trunk side trim panel.

NOTE: Make sure that all the surfaces are coated with anti-rust agent since the areas to be covered are relatively extensive.

Nozzle used: A

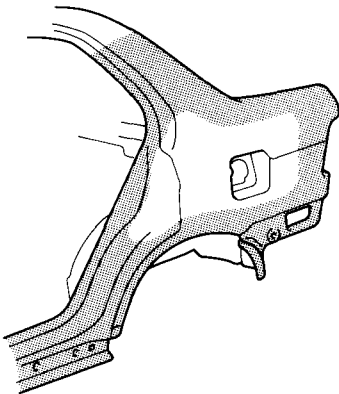
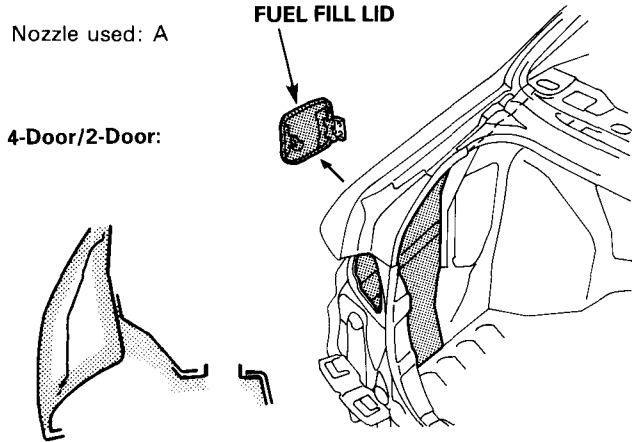

3-Door:

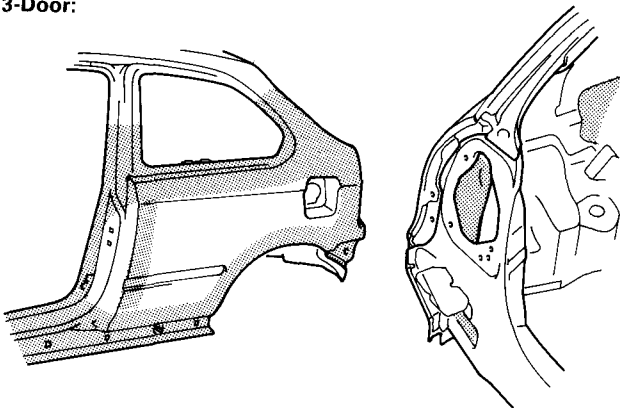

### Trunk Lid and hatch. Inside

- Coat the trunk lid or hatch outer panel and frame seams all the way around.
- On the trunk lid and hatch, apply the agent to the inside of the reinforcement frame.

Nozzles used: A and B

4-Door/2-Door:

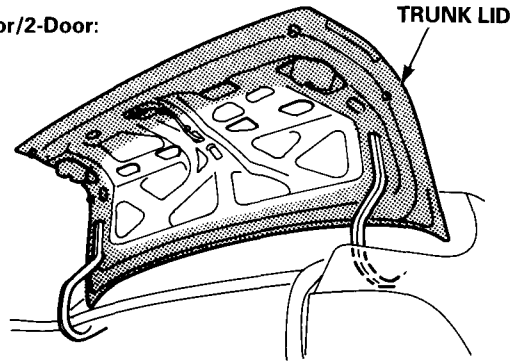

3-Door:

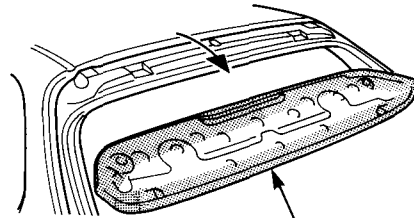

Apply agent to the entire surface of the back of the hatch spoiler (DX).

**HATCH**

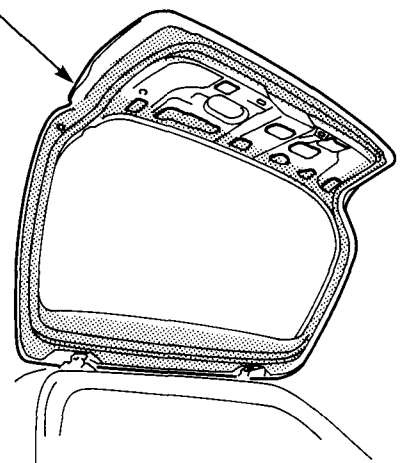

**Rear Panel, Inside and Outside/Rear Floor End**

- Apply the agent to the gap between the rear panel and rear floor.
- Apply the agent to the inside of the rear panel upper, side and center stiffener.
- Undercoat may be used on those areas of the rear panel that are concealed from view when parts are installed.
- Apply the agent to the inside of the jack-up stiffener.

NOTE: Apply the agent to the inside of the bumper face stiffener.

Nozzle used : B

**4-Door/2-Door:**

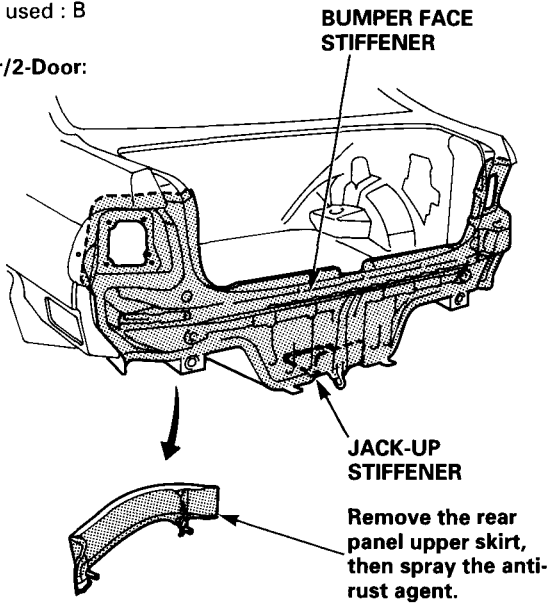

**3-Door:**

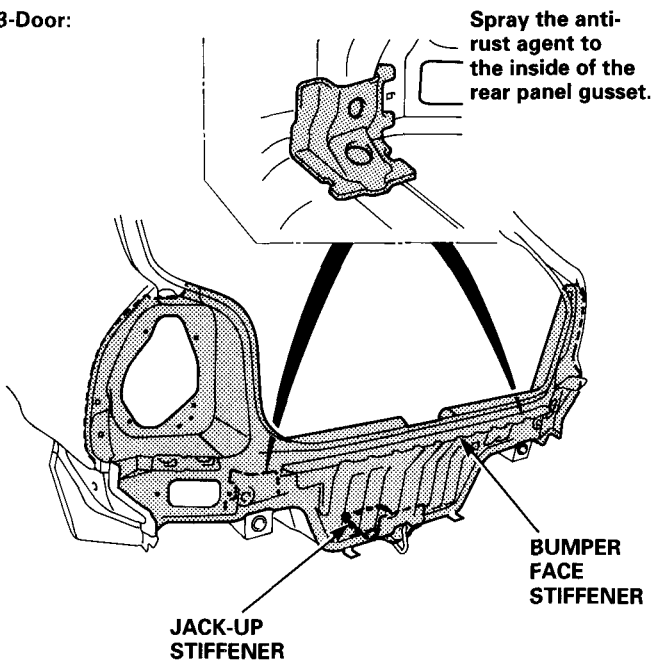

**Front Side Frame, Inside**

- Remove the grommets from inside the front compartment and coat the inside of the front side frame.
- Coat the battery mount bracket base.
- Apply the agent to inside of the front side outrigger.

Nozzles used: A and B

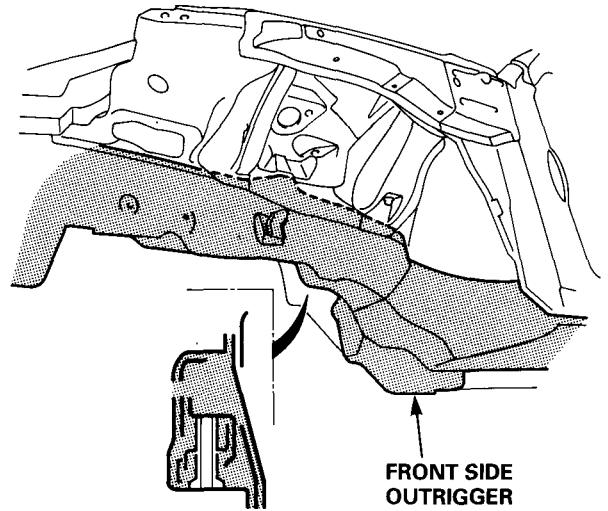

**Engine Side Mount Bracket/Transmission Mount Bracket (CVT), Inside**

Spray anti-rust agent to the inside of the engine side mount and transmission mount bracket.

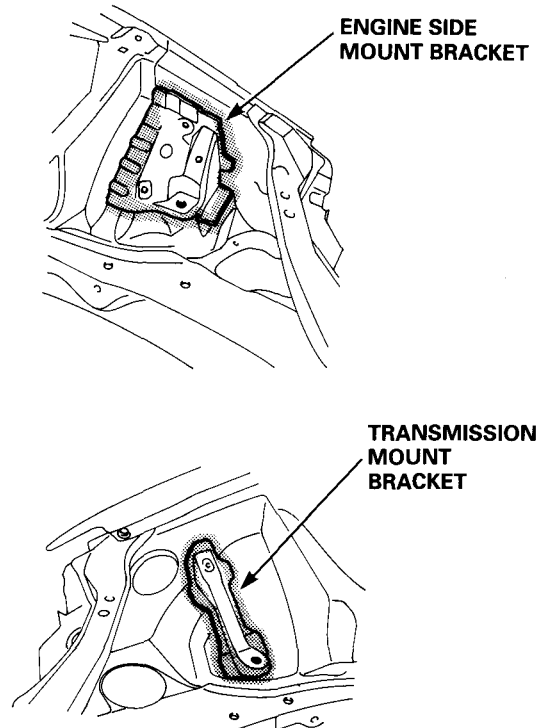

(cont'd)

# Rust-preventive Treatments

## Area to be Covered by Anti-rust Agents (cont'd)

### Damper Housing

- Spray agent on the wheelhouse, front fender stay, upper member and damper base.
- Undercoat the wheelhouse where anti-rust agent or undercoat has not yet been applied.

#### NOTE:

- Coat the wheelhouse upper member, particularly the upper face.
- Undercoat the inner fender mounting area of the wheelhouse and upper face of the inner fender.

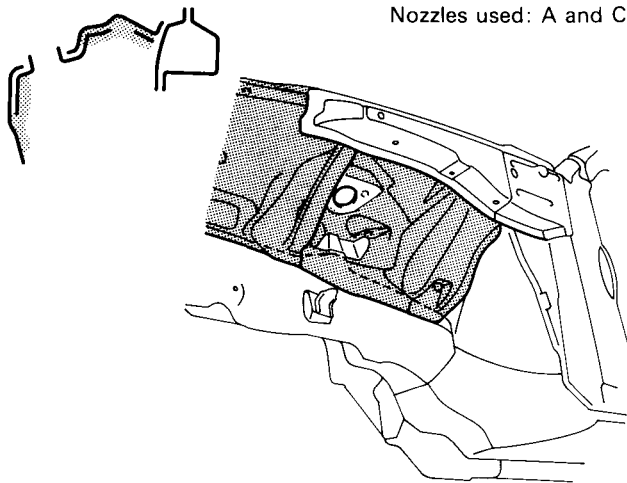

### Rear Wheelhouse

- Coat the gaps between the inner and outer wheelhouses, including the damper base.
- Apply agent to the edge of the rear side frame, side sill and rear floor.
- Undercoat the wheelhouse where undercoat or anti-rust agent has not yet been applied.

Nozzles used: B and C

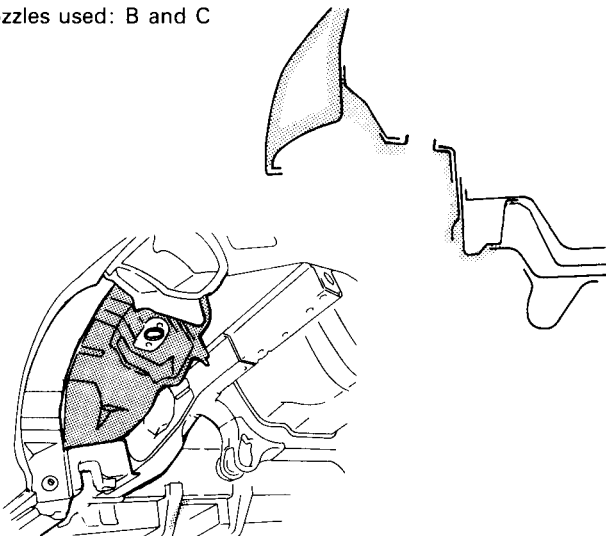

### Side Sill, Inside

- Remove the front and rear grommets and side sill panel to spray agent.
- Insert the nozzle all the way through the grommet holes and spray. Move the nozzle right and left, and up and down while pulling it back out of the grommet hole.

NOTE: Spray agent until it drips from the drain hole.

Nozzle used: A

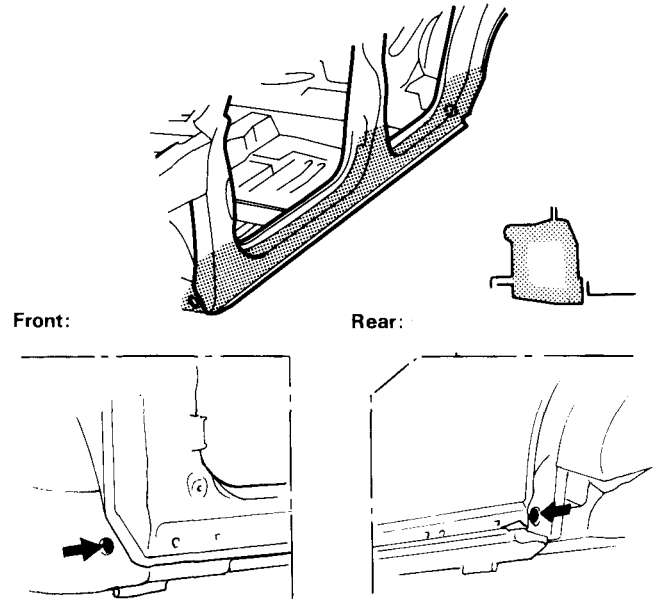

### Under-Floor Member/Floor Frame, Inside

- To spray agent to the inside of the under floor member, insert the nozzle in the holes in the members.
- Also coat the under-floor, side sill, and front and rear wheelhouses at the ends.

Nozzle used: A

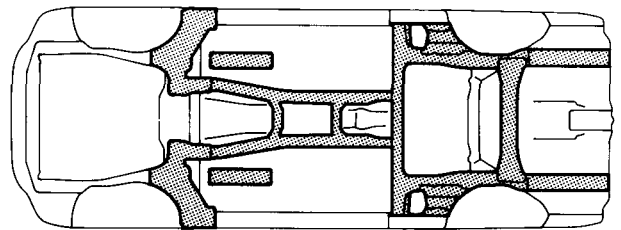

**Under-Floor**

- Undercoat the under-floor where undercoat or anti-rust agent has not yet been applied.
- Coat the bottom of the fuel tank.

**NOTE:**

- Apply undercoat to all the under-floor surfaces of cars already in use.
- Do not apply to the exhaust system and engine belts.

Nozzle used: C

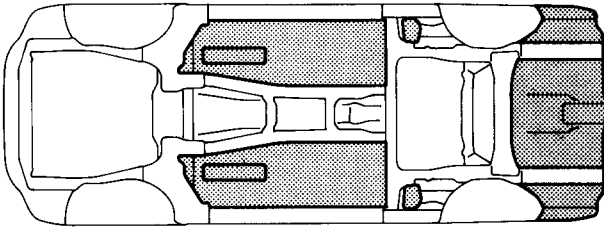

**Suspension**

NOTE: Do not apply to the brake disc and brake caliper.

Coat the outside (and inside if necessary)

- Front Beam
- Rear Beam
- Beam Bracket
- Beam Bridge
- Damper
- Upper Arm
- Steering Knuckle
- Rear Cross Beam
- Lower Arm
- Radius Rod
- Stabilizer
- Brake Pipe

**Front:**

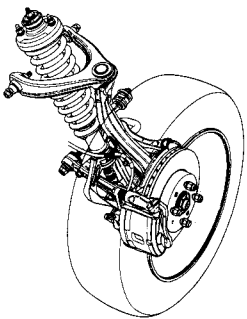

**Rear:**

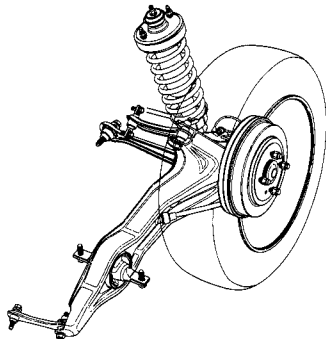

# Rust-Preventive Treatments

## Undercoating Diagram

**NOTE:**

- Coating thickness: 0.5 mm (0.02 in) MIN.
-  indicates PVC coating areas.
- Follow the above instructions for paint repair or refinishing.
- Coating thickness 1 mm (0.04 in) on jack-up bracket and floor and wheelhouse flange seams.
- Avoid coating on the front and rear suspensions, and exhaust system mount area.

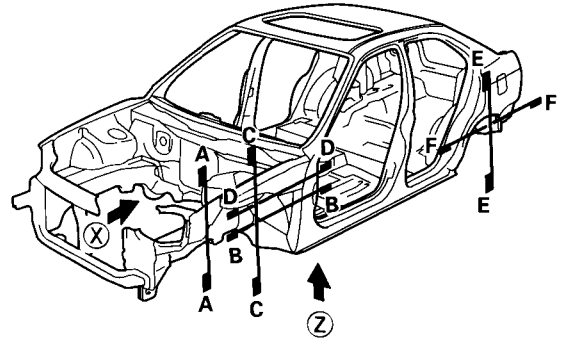

Unit: mm (in)

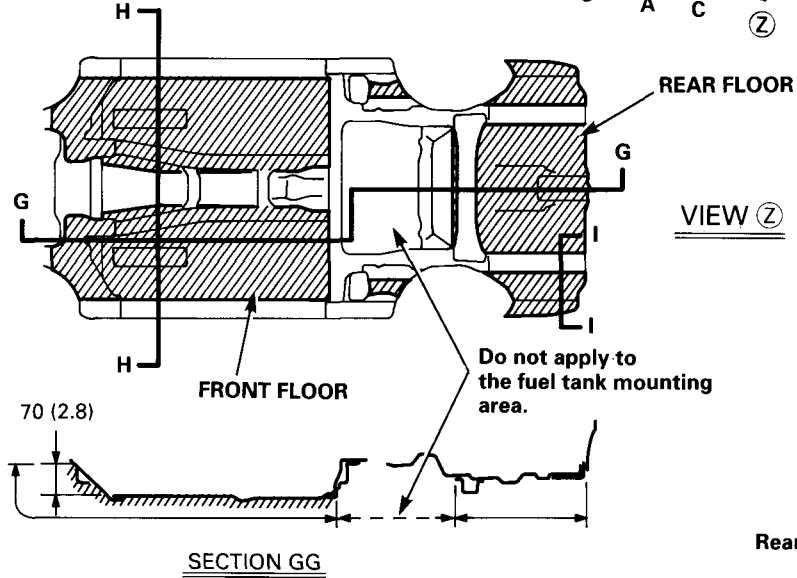

**Front Wheelhouse:**

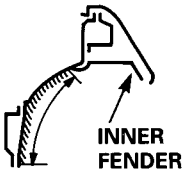

SECTION AA

Overlap undercoat with the inner fender 20 (0.8).

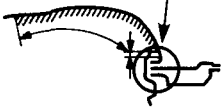

SECTION BB

**Front Damper Housing:**

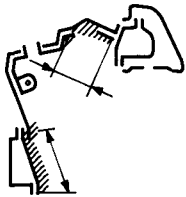

SECTION CC

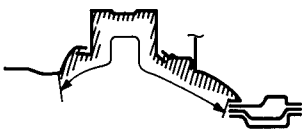

SECTION DD

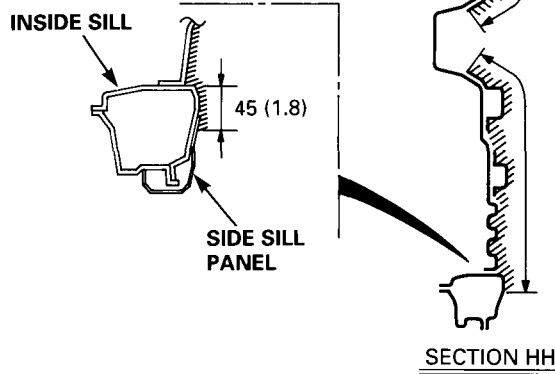

**Dashboard Lower:**

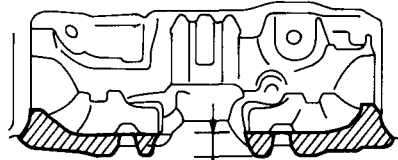

70 (2.8)

**Rear Damper Housing:**

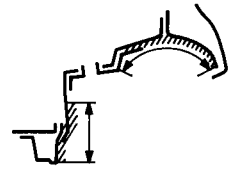

SECTION EE

Do not apply to the fuel fill pipe cover mounting area.

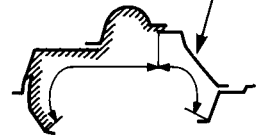

SECTION FF

**REAR FLOOR**

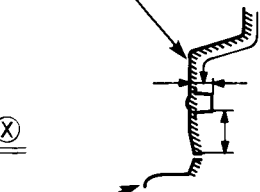

**OUTER PANEL**

SECTION II

VIEW X



# Body Paint Repair

## Color Chart Painting Specifications

4-Door .....	8-2
3-Door .....	8-3
2-Door .....	8-4

## 3C·3B (3-Coat·3-Bake) Paint

General .....	8-5
Paint Refinishing .....	8-6
Defects and Refinishing Processes .....	8-6
Refinishing Processes .....	8-7
Refinishing Procedures .....	8-8

## Soft Chipping Guard Primer Coat

General .....	8-12
Coating Diagram .....	8-13
Types of Soft Chipping Guard Primer (Reference) ..	8-14
Repair Material and Tools .....	8-14
Coating Procedures .....	8-15

# Color Chart Painting Specifications

## 4-Door

Paint Code	USA model			Canada model	
	DX	LX	EX	LX	EX
NH-503P Granada Black P		○	○	○	○
NH-538 Frost White	○	○	○	○	○
NH-583M New Vouge Silver M	○	○	○	○	○
R-95P Island Coral P		○			
G-82P Cypress Green P	○	○	○	○	○
B-73M Cyclone Blue M	○	○		○	○

P : Pearl paint  
M: Metallic paint

Part Name	USA model			Canada model	
	DX	LX	EX	LX	EX
*1 Door Mirror	*	*	○	*	*
*2 Outer Handle	*	*	○	*	*
*3 Protector Molding	*	*	○	*	*
*4 License Plate Trim	*	*	○	*	○

\* : NH-72 Black (Gloss 30)  
○ : Body Color

NOTE: When body color are NH-538, NH-583M, R-95P and B-73M, apply NH-86 black (Gloss 40) to the front and rear wheelhouses.

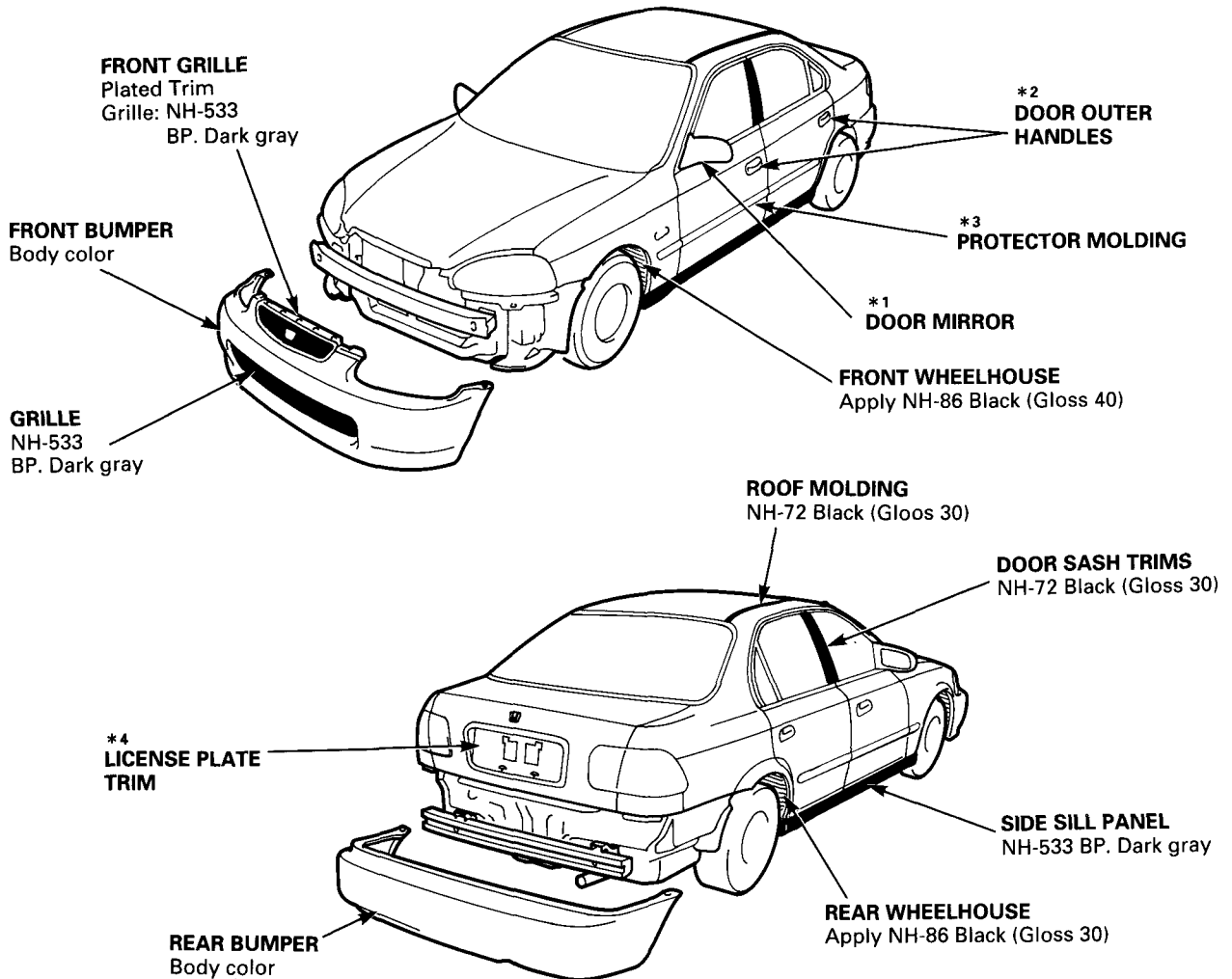

# 3-Door

Paint Code	USA model		Canada model	
	CX	DX	CX	CX-G
NH-503P Granada Black P		○	○	○
NH-583M New Vouge Silver M	○	○	○	○
R-97 Roma Red	○	○	○	○
GY-16P Midori Green P	○	○	○	○

P : Pearl paint  
M: Metallic paint

NOTE: When body color are NH-583M, R-97 and GY-16P, apply NH-86 black (Gloss 40) to the front and rear wheelhouses.

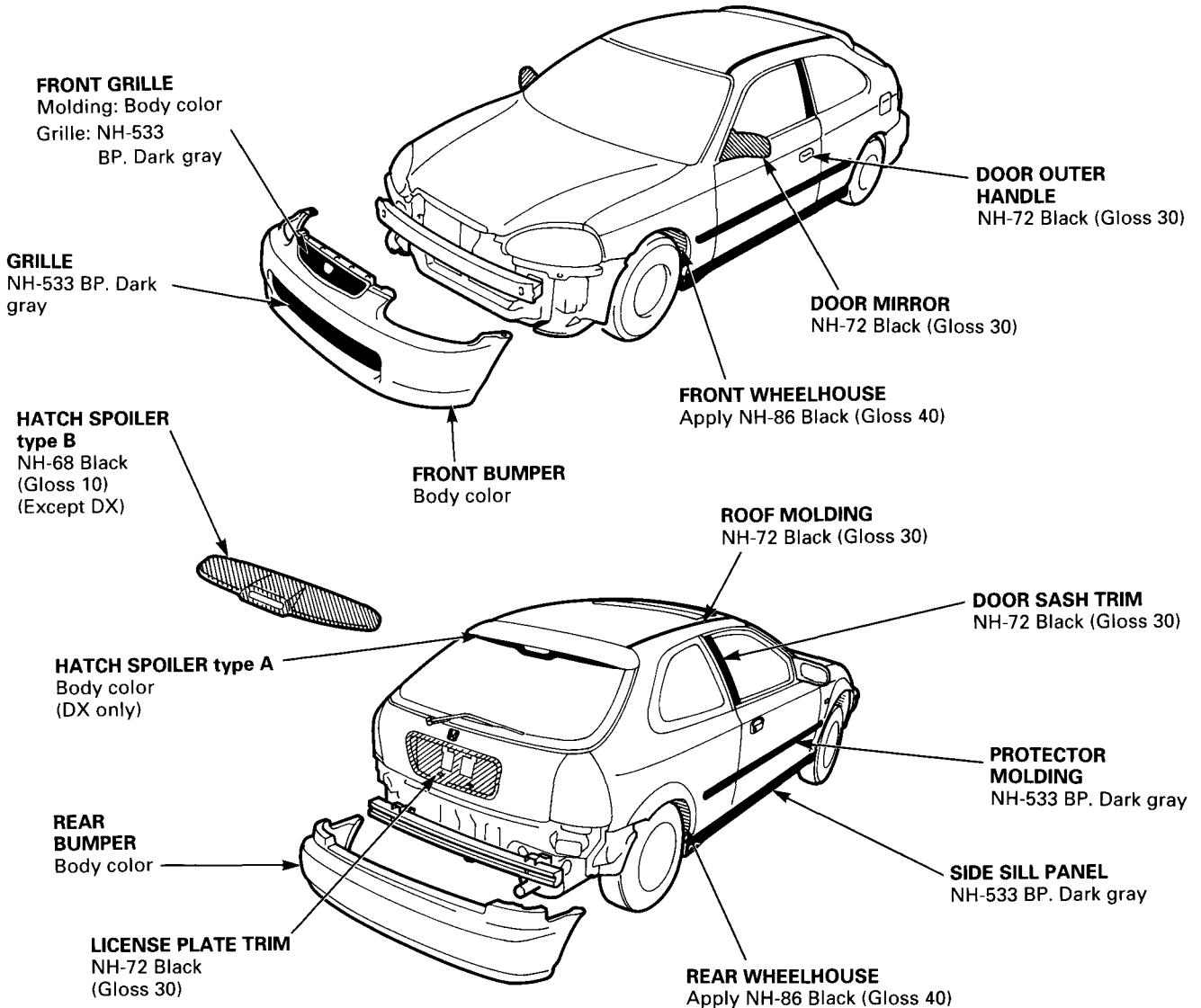

# Color Chart Painting Specifications

## 2-Door

Paint Clde	USA model			Canada model	
	DX	HX	EX	DX	Si
NH-503P Granada Black P	○	○	○	○	○
NH-538 Frost White	○		○	○	○
NH-583M New Vouge Silver M	○		○	○	○
R-81 Milano red	○	○	○	○	○
R-95P Island Coral P	○	○		○	
G-82P Cypress Green P			○		○

P : Pearl paint  
M: Metallic paint

Part Name	USA model			Canada model	
	DX	HX	EX	DX	Si
*1 Door Mirror	*	*	○	*	○
*2 Door Outer Handle	*	*	○	*	○
*3 Protector Molding	*	*	○	*	*
*4 License Plate Trim	*	*	○	*	○

\* : NH-72 Black (Gloss 30)  
○ : Body Color

NOTE: When body color are NH-538, NH-583M, R-81 and R-95P, apply NH-86 black (Gloss 40) to the front and rear wheelhouses.

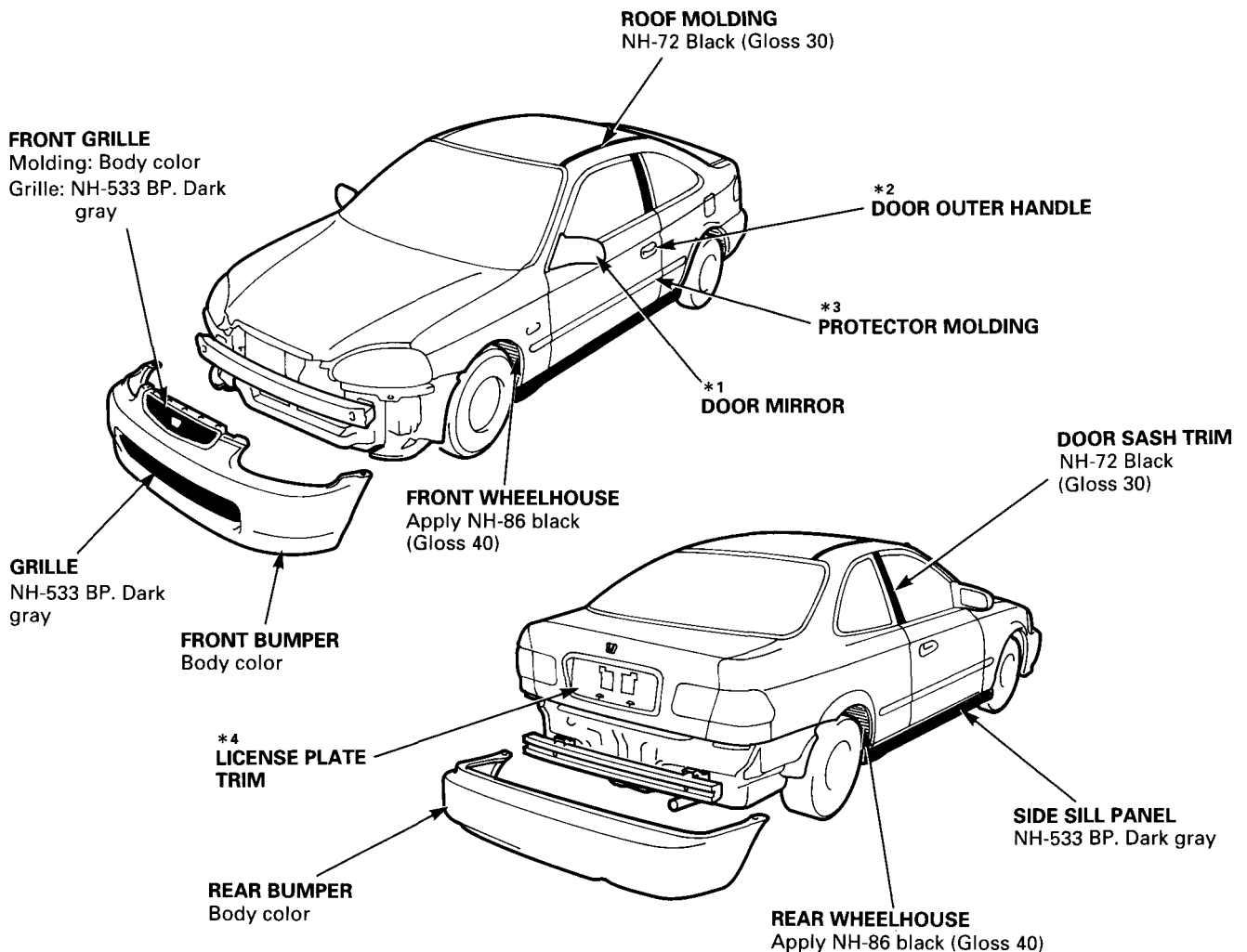

# 3C•3B (3-Coat•3-Bake) Paint

## General

3C•3B paint finish gives the Civic a deep gloss and stunning finish. This manual provides information on paint defect repair and refinishing. Throughout, the objective has been to explain in a simple yet comprehensive manner the basic items you should know about pain repairs. Select the correct material for the defect and repaint or refinish in the correct manner a described in this manual.

### ⚠ WARNING

- Most paints contain substances that are harmful if inhaled or swallowed. Read the paint label before opening the container. Spray paint only in a well ventilated area.
- Cover spilled paint with sand, or wipe it up at once.
- Wear an approved respirator, gloves, eye protection and appropriate clothing when painting. Avoid contact with skin.
- If paint gets in your mouth or on your skin, rinse or wash thoroughly with water. If paint gets in your eyes, flush with water and get prompt medical attention.
- Paint is flammable. Store it in a safe place, and keep it away from sparks, flames or cigarettes.

### Basic Rules in Repairing a 3C•3B paint finish

To repair paint damage, always use the 2-part acrylic urethane paints designated; polish and bake each of the three coats, as in production, to maintain the original film thickness, and to assure the same quality as the original finish.

### Outline of Factory Painting Process:

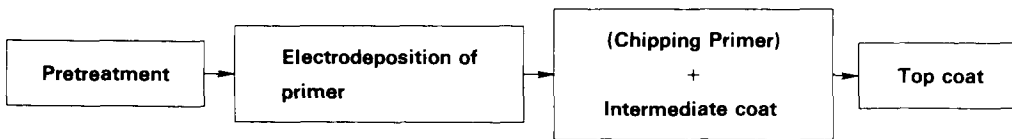

### Features in Each Work Process

#### 1. Pretreatment and Electrodeposition

In the pretreatment process, the entire body is degreased, cleaned, and coated with zinc phosphate by dipping. After the body has been cleaned with pure water, it is placed in an electrolytic bath of soluble primer (Cationic Electrodeposition). This produces a thorough corrosion inhibiting coating on the inner surfaces and corners of the body, pillars, sills and panel joints. Chipping primer is then applied to the most susceptible areas (see page 8-13).

#### 2. Intermediate coat

The intermediate coat is applied to the prepared surface for further protection against damage.

#### 3. Top coat

Enamel paint and either polyester or acrylic resin paint are used in the top coat for higher solidity, smoothness, brightness, and weather resistance.

### Sectional View of Paint Coats:

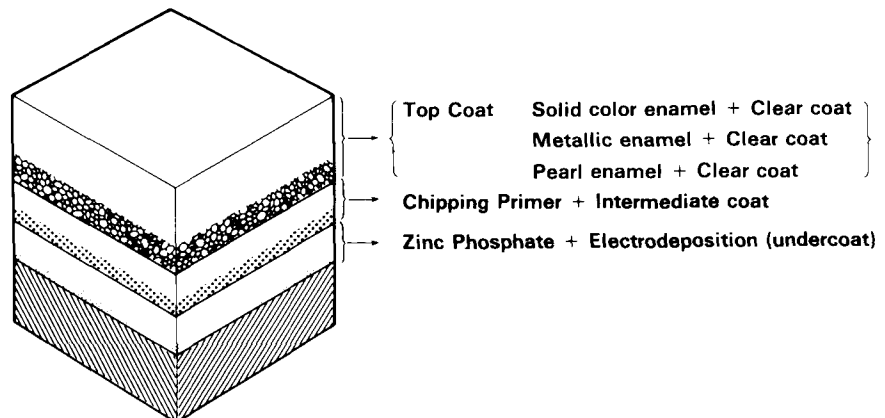

# 3C•3B (3-Coat•3-Bake) Paint

## Paint Refinishing

Paint damage can appear in any form. Before making a repair, check the damaged area carefully, and determine the procedure best suited to the type. The following relates paint refinishing methods to various types of paint damage or defects.

## Defects and Refinishing Processes

### ⚠ WARNING

- **Ventilate when spraying paint.** Most paint contains substances that are harmful if inhaled or swallowed. Read the paint label before opening the paint container.
- **Avoid contact with skin.** Wear an approved respirator, gloves, eye protection and appropriate clothing when painting.
- **Paint is flammable.** Store it in a safe place, and keep it away from sparks, flames or cigarettes.

### A. Damage or defects that have gone through to the metal surface

Rusting or deformation:

Steps:

- ① Featheredge the damaged area.
- ② Prepare the metal surface.
- ③ Apply a chemical coating to metal surface.  
Metal conditioner, Precoat, A.C.P treatment
- ④ Apply an undercoat (primer surfacer)
- ⑤ Apply an intermediate coat (color matched to top enamel paint).
- ⑥ Apply a top coat (body color paint).  
Solid color: Enamel top coat paint  
Metallic color: Metallic enamel paint + Clear top coat  
Pearl color: Pearl enamel paint + Clear top coat

### B. Damage or defects up to undercoat or intermediate coat

External damage or blisters:

- (1) Perform Steps: ④ through ⑥ under Item A.

### C. Damage or defects that have not gone through to intermediate coats (only in top coat)

Shallow scratches or score marks:

- (1) If damage has gone through to the metallic paint, spray metallic enamel, then apply top coat wet on wet.
- (2) If damage has not reached the metallic paint and remained in the clear top coat, polish the damaged surface or-spray clear top coat alone.

NOTE: Try to repair by polishing as much as possible if the damage has not reached metallic paint.

### D. Replacement of Parts

#### -1 Welded parts

Rear side outer panel, etc.



- (1) Perform Step ① through ⑥ if the damaged area is covered with filler or welded with reinforcement plate.
- (2) Perform Step ⑤ and ⑥ for undercoats except those on joints (Intermediate coat for replacement parts).
- (3) On inner panels, apply paint where the undercoats is burned by heat of welding. Follow this with a rust preventive treatment (see [section 7](#)).

#### -2 Single Parts

- Painting of outer and inner hood, door, trunk lid, hatch, etc.  
Perform Step ⑤ and ⑥ of Item A.
- Painting of inside of front fender.  
Only enamel top coat paint may be used:  
Solid color enamel. Metallic enamel or Pearl enamel.
- After spraying enamel paint, perform rust preventive treatment (apply inner or outer rust preventive agent).

# Refinishing Processes

NOTE: (  ): Indicates steps which may be required depending on the degree of damage)

Refinishing Processing	Damage	To metal surface	To under/intermediate coats	To top coat	Replacement Parts	
					Welded part	Single part
1. Featheredging (polishing damaged surface)		↑			↑	
2. Preparation of metal surface		↑			↑	
3. Air blowing/Degreasing		↑			↑	
4. Treatment of metal surface		↑			↑	
5. Filling/drying/Polishing		↑ 			↑	
6. Air blowing/Degreasing		↑			↑	
7. Masking (part)		↑			↑	
8. Undercoating/Drying		↑	↓ 		↑	
9. Polishing undercoat		↑	↓		↑	
10. Air blowing/Degreasing		↑			↑	
11. Masking		↑			↑	
12. Spraying intermediate coat/Drying		↑			↑	↓ 
13. Polishing intermediate coat/Top coat		↑		↑	↑	↓
14. Air blowing/Degreasing		↑		↑	↑	↓
15. Masking		↑		↑	↑	↓
16. Spraying top coat/Drying		↑		↑	↑	↓
17. Polishing/Buffering		↓	↓	↓	↓	↓

# 3C•3B (3-Coat•3-Bake) Paint

## Refinishing Procedures

### 1. Featheredging (polishing damaged areas)

- 1 .Damage to metal surface
- Sand the damaged area flat and smooth with a double action sander and #60 or #80 disc paper.
- Sand the boundary between the metal surface and undercoat with a double action sander and #180 or #280 disc paper. Try to sand a larger area than the damage.

#### NOTE:

- Make sure there is no height difference between the metal surface and undercoat.
- If double action sander is not available, use a rubber block and wrap sandpaper around it to sand the surface.

**⚠ WARNING** To prevent eye injury, wear goggles or safety glasses whenever sanding, cutting or grinding.

- 2. Damage to Undercoat
  - Intermediate coat
  - Top coat
  - Paint coat on replacement parts

Sand the damaged surface flat and smooth with a double action sander and #280 or #320 paper.

#### NOTE:

- If double action sander is not available, use a rubber pad and wet or dry sand the surface with #280, #320, #400 or #600 sandpaper.
- After sanding, check that the surface is flat and smooth.
- Perform the operations in Item 1-1 above for the areas where parts are welded to the body.

### 2. Preparation of metal surface.

Remove all corrosion from the damaged area using a #180 or #280 paper.

### 3. Air Blowing/Degreasing

Air blow the sanded area, then degrease with a wax and grease remover.

#### **⚠ WARNING**

- Do not use high air pressure: Use only an approved, 210 kPa (2.1 kgf/cm<sup>2</sup>, 30psi) air nozzle.
- Wear goggles or safety glasses to prevent eye injury.

### 4. Treatment of metal surface

- Brush or spray a solution of chrome phoshate or washer primer on the exposed metal surface.
- Use the following materials to treat the metal surface:
  - Metal conditioner (kamsai Paint)
  - ACP agent (Nippon Paint)
  - Precoat (Isam Paint)

#### NOTE:

- Follow the manufacturer's instructions.
- Treat the metal surface, as much as possible, to provide a better bonding surface for the subsequent paint.

### 5. Application of Filler

#### Drying Sanding

- Small cracks or pinholes in the sheet metal should be repaired with a filler and sanded flat and smooth.

#### NOTE:

- Mix the putty with the hardener in the correct ratio.
- Follow the filler manufacturer's instructions.



**⚠ WARNING** Body parts being dried with an industrial dryer can get hot enough to cause injury. Do not touch parts being dried.

- Allow the filler to air dry for about 5-6 minutes, then force dry with an infrared lamp.

NOTE: Keep the lamp 40-50 cm (16-20 in) from the filler while drying.

- Stop drying the filler if a white mark appears when the surface is scratched with your nail. Wet or dry sand the surface flat and smooth with a #280 or #320 paper.

## 6. Air Blowing/Degreasing

Air blow the surface to be repaired, then degrease with a wax and grease remover.

NOTE: Also clean and degrease surfaces where masking tape will be attached.

## 7. Masking

Mask the areas surrounding the damage to prevent overspray from the primer.

## 8. Application and Drying of Primer/Drying

**⚠ WARNING**

- **Ventilate when spraying paint. Most paint contains substances that are harmful if inhaled or swallowed. Read the paint label before opening the paint container.**
- **Avoid contact with skin. Wear an approved respirator, gloves, eye protection and appropriate clothing when painting.**
- **Paint is flammable. Store it in a safe place, and keep it away from sparks, flames or cigarettes.**
- Spray the primer over the filler and surface (use epoxy or urethane 2-part primer).  
Spray : 2-3 coats.

- Use the following materials:
  - 615S Primer Surfacer (DuPont)
  - Primer Surfacer EP (Akzo)
  - NPS735 Urethane Primer Surfacer (R-M)

- Let the primer air dry for 5-10 minutes, then force dry with an infrared lamp.

NOTE: Keep the dryer 40-50 cm (16-20 in) from the surface.

## 9. Application of Polishing Undercoat

- Remove the masking paper and tape.
- Check that the undercoat has dried thoroughly, then dry or wet sand the surface with a #280 or #320 paper.

NOTE:

- Use a rubber block and sand flat and smooth.
- Sand the entire surface to be refinished.

## 10. Air Blowing/Degreasing

**⚠ WARNING**

- **Do not use high air pressure; use only an approved, 210 kPa (2.1 kgf/cm<sup>2</sup>, 30 psi) air nozzle.**
- **Wear goggles or safety glasses to prevent eye injury.**

Air blow all the surfaces, then degrease with wax and grease remover (for USA usage-DuPont 38125 Enamel Reducer).

NOTE: Also degrease the surfaces where masking tape will be attached.

## 11. Masking

Mask the undamaged areas surrounding the damage to prevent overspray from primer surfacer (undercoat).

NOTE: Use masking tape and paper to mask the body. A vinyl cover may also be used to effectively mask the body.

(cont'd)

# 3C-3B (3-Coat-3-Bake) Paint

## Refinishing Procedures (cont'd)

### 12. Application of Intermediate Coat (same color as enamel) top coat spraying/Drying

#### ⚠ WARNING

- **Ventilate when spraying paint. Most paint contains substances that are harmful if inhaled or swallowed. Read the paint label before opening the paint container.**
- **Avoid contact with skin. Wear an approved respirator, gloves, eye protection and appropriate clothing when painting.**
- **Paint is flammable. Store it in a safe place, and keep it away from sparks, flames or cigarettes.**
- Use the same color paint as the top coat. Spray it over the surface until the undercoat (primer surfacer) is fully covered.
- Spray the paint slightly thicker than normal to allow for loss during subsequent polishing.
- Super ponacle II (R-M)
- Super Centri (DuPont)
- Auto cryl (Akzo)

### 13. Polishing of Intermediate Coat

- Check that the paint coat has dried thoroughly, then dry or wet sand the surface with a #600 and #800 paper.

NOTE: Use a rubber block and sand flat and smooth, being careful not to expose the undercoat.

#### Polishing of Top Coat (if damaged):

Use the same technique described above.

### 14. Air Blowing/Degreasing

#### ⚠ WARNING

- **Do not use high air pressure; use only an approved, 210 kPa (2.1 kgf/cm<sup>2</sup>, 30 psi) air nozzle.**
- **Wear goggles or safety glasses to prevent eye injury.**
- Air blow the entire surface, then degrease with wax and grease remover.
- For shading or spot painting, polish the area with a polishing compound. Sand with a #2000 paper to give a better bonding surface for the subsequent paint.

### 15. Masking

- Remove all existing masking paper, then mask with new paper.
- Use a heat resistant type masking tape (SCOTCH TAPE) where tape is attached directly to the body.
- Use brown paper or masking roll paper to cover.

#### NOTE:

- Mask the area surrounding the damage sufficiently to prevent overspray. It is also a good practice to use a vinyl cover to protect other areas.
- Protect resin parts with aluminum foil under the brown paper or masking paper to prevent damage due to heat during baking.

### 16. Application of Top Coat Spraying/Drying

- Prior to putting the car in the painting booth, thoroughly clean the interior and spray water over the floor. Be careful about blowing dust and dirt.

#### ⚠ WARNING

- **Do not use high air pressure; use only an approved, 210 kPa (2.1 kgf/cm<sup>2</sup>, 30 psi) air nozzle.**
- **Wear goggles or safety glasses to prevent eye injury.**
- Air blow and degrease the surface before spraying the paint. Also clean the surface with a tack cloth.

#### ⚠ WARNING

- **Ventilate when spraying paint. Most paint contains substances that are harmful if inhaled or swallowed. Read the paint label before opening the paint container.**
- **Avoid contact with skin. Wear an approved respirator, gloves, eye protection and appropriate clothing when painting.**
- **Paint is flammable. Store it in a safe place, and keep it away from sparks, flames or cigarettes.**
- Spray color matched top coat over the prepared surface. Apply 2-3 coats in two directions until the intermediate coat is fully covered.

NOTE: For application of the top coat, refer to step 12 "Application of Intermediate Coat."

Solid color: Color enamel + Color clear coat

Metallic color: Metallic enamel + Clear coat

Pearl color: Pearl enamel + Clear coat

**⚠ WARNING** Body parts being dried with an industrial dryer can get hot enough to cause injury. Do not touch parts being dried.

- After spraying, allow the paint to settle for about 10 minutes, then force dry with an infrared lamp.

NOTE: Follow the paint manufacturer's instructions.

### 17. Polishing/Buffering

- Let the paint dry gradually, then polish the surface carefully using a polishing compound and sponge buff.
- To remove lint or dirt, wet sand the surface with #2000 paper or finer first, then polish with compound.

NOTE: Polish all roughness caused by sanding thoroughly. To do this, first polish with very fine compound, then with ultra fine compound.

- After polishing, remove the masking paper and tape, then wash the entire vehicle thoroughly.

# Soft Chipping Guard Primer Coat

## General

The removal of paint and undercoating by stones and gravel immediately exposes metal to the atmosphere, causing it to rust. The thickness of this rust increases if the process continues unchecked. The soft chipping guard primer protects against damage due to the impact of flying objects. The purpose of this guide is to provide information you will find useful when repairing damage to the protective coating. Refer to the Soft Chipping Primer Undercoating Diagram.

Type	Composition	Physical properties	Drying time
Polyester resin	Polyester resin Pigment Additive Solvent	Color Gray Viscosity 26sec/68°F (20°C) at painting Non volatile 40~45% at painting	302~320°F (150~160°C) × 30 minutes

The soft chipping guard primer is applied over the E.D. (Electrostatically Deposited) primer. It is followed by guide coating and top coating.

The soft chipping guard primer produces a smooth surface when dry. It should be sprayed so the thickness of the protective film is 20 microns.

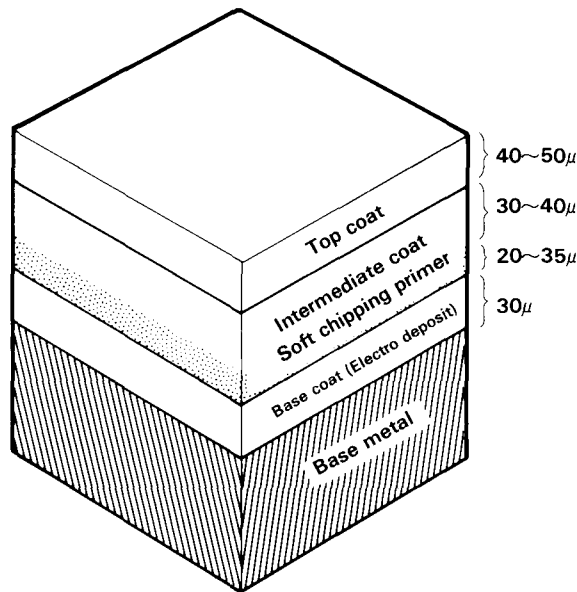

# Coating Diagram

The diagram shows the areas to which soft chipping primer is to be applied.

NOTE: Make sure to coat the flange on front and rear wheel arches.

Unit: mm (in)

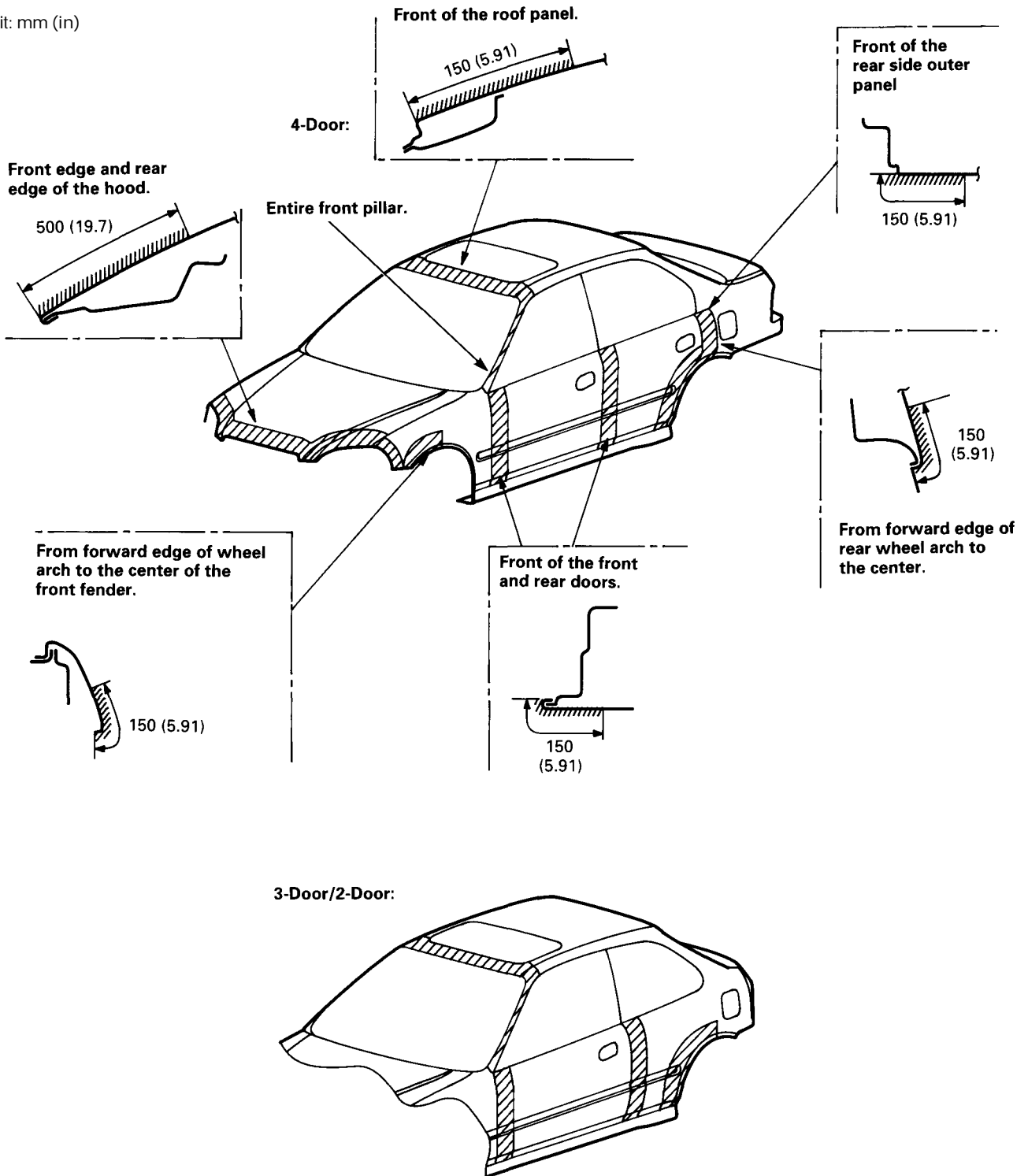

# Soft Chipping Guard Primer Coat

## Types of Soft Chipping Guard Primer (Reference)

Type	Application	Composition	Physical property	Drying time
Dual liquid synthetic resin	Room temperature Baked at 176°F (80°C) for 40 minutes	Pigment: 12% Calcic pigment: 37% Epoxy polyole resin: 15% Additive, Solvent 36% ----- 100%	Color: Gray Viscosity: 68°F (20°C) Non volatile: 65% mini. Specific gravity: 68°F (20°C), 1.378	Room temperature: 68°F (20°C), 3 days Baked: 176°F (80°C), 40 minutes (to harden thoroughly)
Dual liquid Acrylic Urethane } resin	Room temperature Baked at 176°F (80°C) for 30 minutes.	Pigment: 40% Acrylic resin: 37% Additive, Solvent 23% ----- 100%	Color: Gray Viscosity: 68°F (20°C) 4-6 Poiseuille Non volatile: 65% mini. Specific gravity: 68°F (20°C), 1.35	Room temperature: 68°F (20°C), a day Baked: 176°F (80°C), 30 minutes (to harden thoroughly)

## Repair Materials and Tools

### Gun and brushes:

- Spray gun  
NOTE: Any gun having a tip of more than 1.0 mm (0.04 in) in diameter may be used for spraying the primer.
- Viscosity measure  
Iwata-type (IHS) cup, Ford cup
- Beaker  
1-2 ℓ (1.05-2.10 US. qt, 0.9-2 Imp. qt) in capacity
- Stirring stick

### Materials:

- Use primers equivalent to the ones shown in Types of Chipping Guard Primer (Reference).
- Make sure to keep the thickness of the coat at 20 microns.

### Masking:

- Masking tape, paper, vinyl sheet and plate (veneer and steel).
- Masking plates are not necessary when spraying in a booth.

### Tools:

- Air or double action sander
- Sandpaper (#240- #400)

### Protectors:

- Wear an approved respirator or dust mask, gloves, safety goggles and other protective clothing.
- Rags.

### Thinner and cleaner:

- Use the thinner specified for the primer.
- Any commercially available lacquer thinner may be used to clean the gun.

### **⚠ WARNING**

- Most paints contain substances that are harmful if inhaled or swallowed. Read the paint label before opening the container.
- Spray paint only in a well ventilated area.
- Cover spilled paint with sand, or wipe it up at once.
- Wear an approved respirator, gloves, eye protection and appropriate clothing when painting. Avoid contact with skin.
- If paint gets in your mouth or on your skin, rinse or wash thoroughly with water. If paint gets in your eyes, flush with water and get prompt medical attention.
- Paint is flammable. Store it in a safe place, and keep it away from sparks, flames or cigarettes.

## Coating Procedures

NOTE: This section covers the application of the soft chipping primer to the replacement part.

### 1. Sanding the replacement part

**⚠ WARNING** Wear goggles or safety glasses to prevent eye injury.

Sand the area to be painted with #240-#400 sandpaper.

NOTE:

- Do not oversand the edges or corners of the part.
- Do not expose bare metal.

### 2. Air blowing/ degreasing

**⚠ WARNING**

- Do not use high air pressure; use only an approved, 210 kPa (2.1 kgf/cm<sup>2</sup>, 30 psi) air nozzle.
- Wear goggles or safety glasses to prevent eye injury.
- Paint thinner is flammable. Store it in a safe place, and keep it away from sparks, flames or cigarettes.

Clean the surface with compressed air and wax and grease remover.

### 3. Masking

- Place masking tape or paper around the surface to be painted.
- Cover as wide an area as possible with tape or paper to keep primer from spreading.

### 4. Spraying chipping guard primer

- Stir the primer thoroughly.
- Put the primer in a beaker and weigh the needed amount of primer to be used.
- Mix the hardener into the primer, following the manufacturer's instructions.

NOTE: Measure the primer and hardener so they are in correct ratio.

Item	Primer	:	Hardener
* High Primer Surfacer 2C	10	:	1
* Auto Primer Surfacer Mighty	5	:	1

- Add the specified thinner to the mixture of hardener and primer to attain the proper viscosity for spraying.  
2C 68°F (20°C) 18 sec ± 1
- These substances are not available in the U.S.A. Honda recommends using DuPont's 123 Vinyl Coating, or Sherwin-Williams' Vinyl Gravel Guard. Follow the manufacturer's instructions for application.
- Once mixed with the hardener and thinner, the primer must be used within the times shown below.

Temp.		41°F (5°C)	50°F (10°C)	68°F (20°C)
Time	High Primer Surfacer 2C	30H	24H	8H
	Auto Primer Surfacer Mighty	4H	3.5H	3H

**⚠ WARNING**

- Most paints contain substances that are harmful if inhaled or swallowed. Read the paint label before opening the container. Spray paint only in a well ventilated area.
- Cover spilled paint with sand, or wipe it up at once.
- Wear an approved respirator, gloves, eye protection and appropriate clothing when painting. Avoid contact with skin.
- If paint gets in your mouth or on your skin, rinse or wash thoroughly with water. If paint gets in your eyes, flush with water and get prompt medical attention.
- Paint is flammable. Store it in a safe place, and keep it away from sparks, flames or cigarettes.

(cont'd)

# Soft Chipping Guard Primer Coat

## Coating Procedures (cont'd)

- Fill the gun's paint cup with the primer. Use a strainer when pouring the primer into the cup.
- Primer should never be applied to a dirty or greasy surface. Before spraying, blow dust and dirt off the surface and clean with wax and grease remover.

(Method of spraying)

- Do not try to cover the surface with one heavy coat. Apply several thin coats.

NOTE:

- Spray coat 4-5 coats to get 20 microns of thickness, as one coat deposits 5-7 microns.
- Spray the primer at 250-300 kPa (2.5-3.0 kgf/cm<sup>2</sup>, 35.6-42.7 psi) pressure. Spraying with improper air pressure will cause imperfections.
- Open the gun 3-4 turns.
- Wipe up unwanted primer immediately with thinner.

### 5. Cleaning spray gun

- After spraying, be sure to clean the spray gun thoroughly with thinner or solvent.
- The gun will be permanently clogged if the primer is allowed to dry.

### 6. Drying

- After spraying the chipping guard primer, air-dry for 7-10 minutes to evaporate the thinner in the primer. Then dry it with infrared lamps at 176°F (80°C) for 30-40 minutes.

NOTE: Insufficient baking may cause pinholes if the primer coat is too thick.

- The temperature lamps and drying time recommendations should be followed closely.

### 7. Intermediate and Top coating

- Sand the chipping guard primer film with #280-#400 sandpaper.
- Follow the intermediate/top coating procedures (see page 8-10).

Temperature		41°F (5°C)	68°F (20°C)	86°F (30°C)	140°F (60°C)	176°F (80°C)
Time	Before sanding	8-13H 6-10H	3.5-5H 4-5H	2-3H 2-4H	30 Min. 15-20 Min.	20 Min. 10-15 Min.
	Minimum time	8H 10-18H	4H 6-8H	3H 4-8H	30 Min. 20-40 Min.	20 Min. 15-30 Min.

NOTE: The upper line of time shows specifications for High Primer Surfacer 2C, and the lower line Auto Primer Surfacer Mighty.



# Resin Parts Paint Repair (Exterior)

Types and Materials of Exterior Resin Parts .....	9-2
<b>Polypropylene (PP) Resin Parts</b>	
General Information .....	9-3
Repair Materials and Tools .....	9-3
Refinishing Processes .....	9-5
Repair Procedures .....	9-6
Refinishing Procedures .....	9-7
<b>ABS/PC Resin Parts</b>	
General Information .....	9-12
Repair Materials .....	9-12
Repair Procedures .....	9-13
Refinishing Procedures .....	9-13
<b>Glossary</b> .....	9-15

# Types and Materials of Exterior Resin Parts

4-Door:

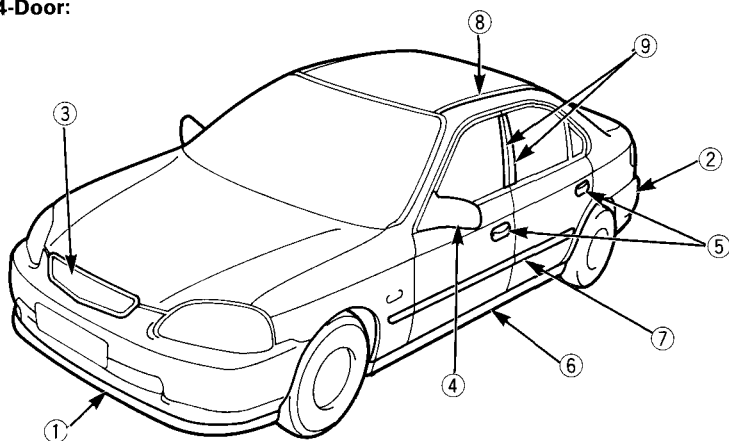

NOTE: A standard symbol is stamped on the underside of each resin part to show the type of material of used.

Example:

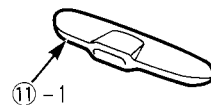

2-Door:

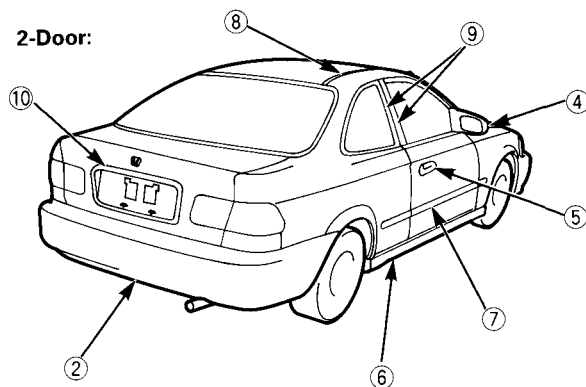

3-Door:

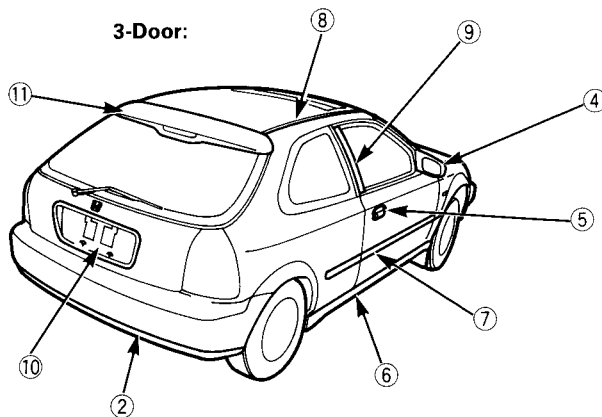

No.	Part Name		Material
①	Front Bumper		Polypropylene (PP)
②	Rear Bumper		Polypropylene (PP)
③	Front Grille		Polypropylene (PP)
④	Door Mirror	Body color	Acrylonitrile/Butadiene/Styrene (ABS)
		Black	Acrylonitrile/Styrene/Acrylate (ASA)
⑤	Outer Door Handle		Poly carbonate plastics (PC)
⑥	Side Sill Panel		Polypropylene (PP)
⑦	Protector Molding		Polypropylene (PP)
⑧	Roof Molding		Poly vinyl chloride (PVC)
⑨	Door Sash Trim		Acrylonitrile/Ethylene/Styrene (A/EPDM/S)
⑩	License Plate Trim	Body color	Acrylonitrile/Butadiene/Styrene (ABS)
		Black	Acrylonitrile/Ethylene/Styrene (A/EPDM/S)
⑪	Hatch Spoiler Trim (DX only)		Acrylonitrile/Butadiene/Styrene (ABS)
⑪-1	Hatch Spoiler (Except DX)	Upper Panel	Acrylonitrile/Ethylene/Styrene (A/EPDM/S)
		Lower Panel	Acrylonitrile/Butadiene/Styrene (ABS)

● No. ①, ②, ③, ⑥, ⑦, ⑫ : Repair procedures see page 9-6

● No. ④, ⑤, ⑨, ⑩, ⑪, ⑪-1 : Repair procedures see page 9-13

# Polypropylene (PP) Resin Parts

## General

The front bumper, rear bumper, front grille, and side sill panel are made of polypropylene (PP) resin. They can be repaired if the damage or deformation is minor in nature. This section covers PP repair. Repairing PP is different from other resins such as ABS and urethane.

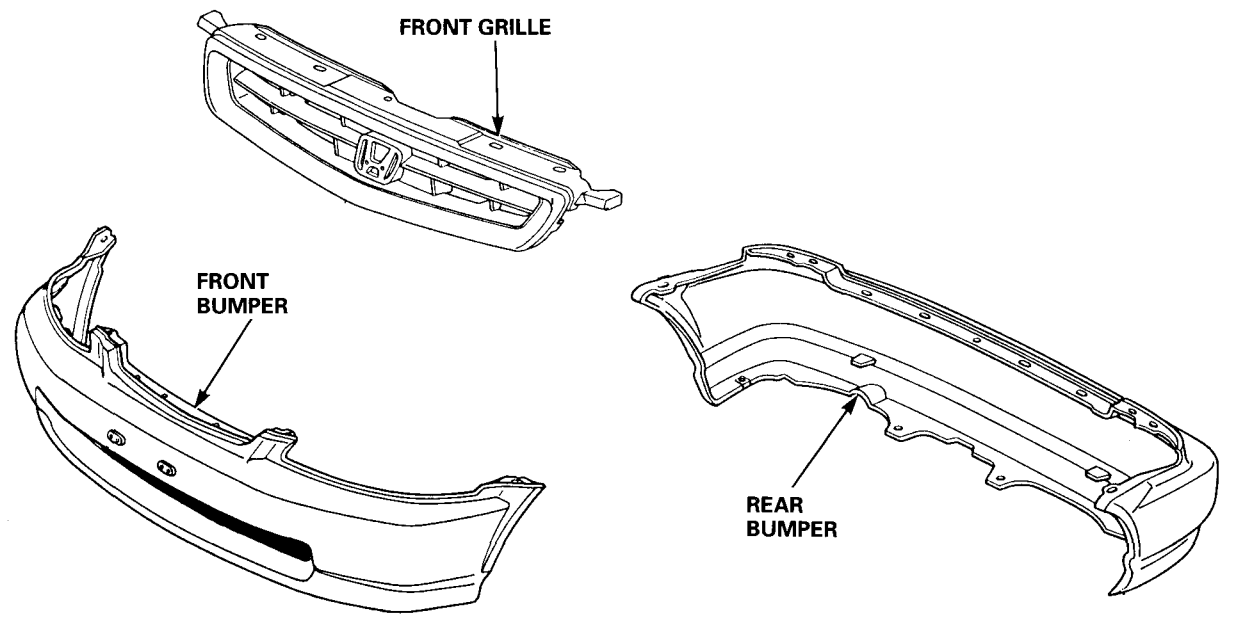

# Polypropylene (PP) Resin Parts

## Repair Materials and Tools

The following materials and tools are required to resin bumpers:

### Adhesive and Filler (examples):

- Bumper primer (clear type)
- Bond quick mender
- High art mat black
- High art thinner
- High art hardener

### Primer surfacer (examples).

- Dual-liquid type bumper primer surfacer (gray) Reference (Isam Paint)
- Pigment: (1kg) (35.3 oz)
- Hardener: (100g) (3.5oz)
- Thinner: (900 m l ) (30.4 f l . oz, 31.7 Imp. oz)

NOTE: Follow the manufacturer's recommendations

### Tools:

- Putty knife
- Base (putty)
- Sandpaper
- Cutter
- Brush
- Masking tape
- Masking paper

### 1. Bumper Primer (Clear): Premixed type

The primer provides a good support for the filler and primer surfacer. It is applied to the surface of the bumper.

Drying time:

Natural	68°F (20°C) 20 minutes
Baked	140°F (60°C) 10 minutes

### 2. PUTTY BOND QUICK MENDER

After the PP primer has dried thoroughly, apply the PUTTY BOND QUICK MENDER.

- 1. Mix one part of the mender (A) and one part of the hardener (B) and stir thoroughly.

NOTE: Do not mix the mender and hardener in excess of 20g (0.7oz) at a time.

(cont'd)

# Polypropylene (PP) Resin Parts

## Materials and Tools (cont'd)

-2. Hardening starts immediately after mixing. Practical hardness will be obtained within 60 minutes. The surface will be tacky within 5 minutes and nearly hardened after 15 minutes. It takes 12 hours for the surface to harden thoroughly 68°F (20°C)

-3. Sanding can be done after:

3 hours	68°F (20°C)-natural drying
30 minutes	140°F (60°C)-baked

### 3. Primer Surfacer

NOTE: Use a dual-liquid type bumper primer surfacer (gray).

- The primer surface is used to protect the PP resin surface and to fill cavities or flaws in the intermediate and top coats.
- Mix 10 parts of primer surfacer and 1 part of hardener. Add the specific thinner (30-60%) to the mixture of the hardener and primer to attain the proper viscosity for spraying.

### 4. Intermediate and Top Paint Coats (Body color)

Grill: Bumper dark gray (NH-533)

NOTE:

- The paints are the dual liquid type based on the color chart.
- Measure the pigment and hardener as described so they are in correct ratio.

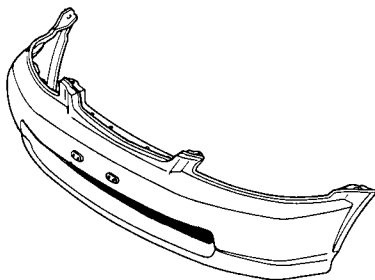

- Use the acrylic urethane paint prepared according to the mixing chart as the intermediate coat.

Mixing Ratio:

Mix 5 parts of body color pigment to 1 part of additive. Mix 4 parts of the mixture of the pigment and additive with 1 part of the hardener.

NOTE:

- Dilute the mixture with 40-50% of the specified thinner (Highart Thinner).
- Be sure to mix the correct amount of the additive.
- Use a spray gun to apply the paint. Do not use a brush.

#### ⚠ WARNING

- Ventilate when spraying paint. Most paint contains substances that are harmful if inhaled or swallowed. Read the paint label before opening the paint container.
- Avoid contact with skin. Wear an approved respirator, gloves, eye protection and appropriate clothing when painting.
- Paint is flammable. Store it in a safe place, and keep it away from sparks, flames or cigarettes.

Drying time:

Natural	68°F(20°C)
Surface only	20 minutes
Almost hardened	4 hours
Thoroughly hardened	96 hours

NOTE: The HIGH ART MAT BLACK SURFACER is a dual liquid type. If mixed, it will harden in a matter of hours.

# Refinishing Processes

## Type of Damage

A. Scratch  
Repaint



● Perform Steps ①, ④ ⑤ through ⑦

B. Hole  
Deep abrasion



● Perform steps ① through ⑦

C. Deep groove  
Deformation



## Repair

① Wet sand the surface with a #240 and #400 sandpaper.

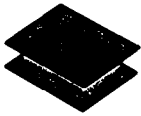

② Spray bumper primer (clear type) or dual-liquid bumper primer surfacer (damaged areas).

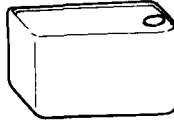

③ Apply filler and sand

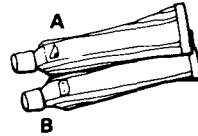

Sand-  
paper

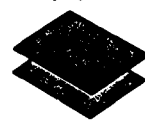

④ Degrease and Air blow



⑤ Spray dual-liquid bumper primer surfacer and dry

Primer  
Surfacer



Hardener



Sandpaper

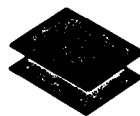

#600

● Wet sand the surface with a #600 sandpaper

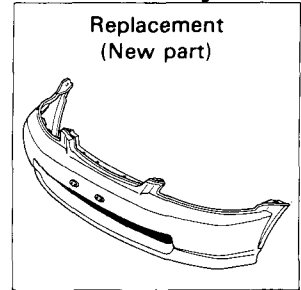

Replacement  
(New part)



⑥ Mask and intermediate coat

- Air blow and degrease the sanded surface.
- Spray paint and dry.

NOTE: Use the paint for top coat enamel.



⑦ Top coat {  
Solid color  
Metallic color  
Pearl color

# Polypropylene (PP) Resin Parts

## Repair Procedures

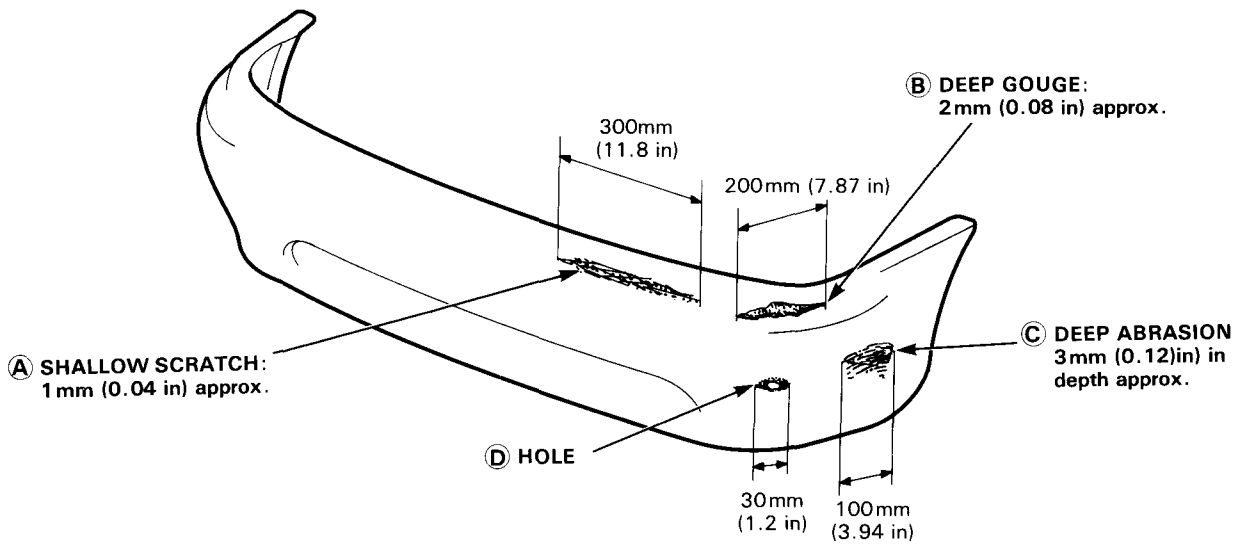

NOTE: ( ): Indicates steps which may be required according to the degree of damage.

Damage	A	B	C	D	Repaint	Replacement
<b>Work Steps</b>						
1. Sanding	↑	↑	↑	↑		
2. Degreasing/Cleaning (damaged areas)						
3. Spraying primer or primer						
4. Drying surfacer						
5. Applying filler	↑	↑	↑	↑		
6. Drying filler						
7. Sanding filler	↑	↑	↑	↑		
8. Degreasing/Cleaning (filled area)						
9. Spraying primer surfacer						
10. Polishing (Air blowing/degreasing)						
11. Intermediate coating						
12. Degreasing/Cleaning						
13. Masking						
14. Top coating					↑	↑
15. Drying top coat					↑	↑
16. Polishing/Buffering					↑	↑

NOTE: Intermediate coating is recommended for bright colors.

## Refinishing Procedures

### 1. Sanding damaged areas

Shallow scratch:

- Level and finish damaged areas with #240- #400 sandpaper.
- Polish the leveled area with #400 sandpaper.

NOTE:

- Use a flexible block to sand the surface evenly.
- Do not remove too much material.

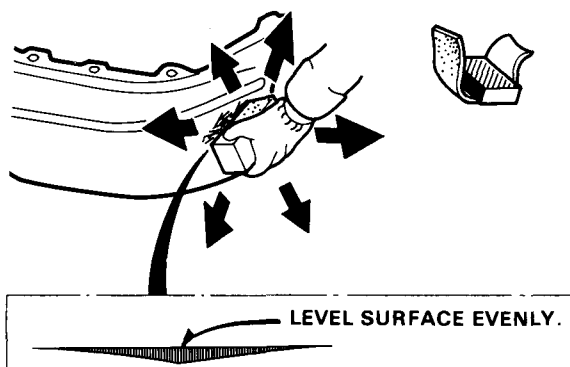

Deep groove/tear:

- Level and finish burrs and other irregularities with #240 sandpaper. Keep the surface as even as possible.

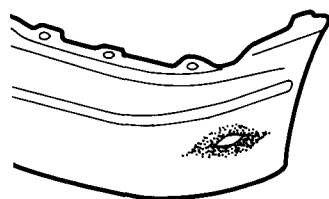

### 2. Degreasing/Cleaning

#### ⚠ WARNING

- Do not use high air pressure; use only an approved, 210 kPa (2.1 kgf/cm<sup>2</sup>, 30 psi) air nozzle.
- Wear goggles or safety glasses to prevent eye injury.
- Clean with wax and grease remover and dry with compressed air.
- Wipe off all lint and other foreign particles from the surface with a tack cloth.

NOTE: Be sure to use a tack cloth. Dust and dirt are electrostatically drawn to the surface.

### 3. Applying bumper primer (clear type).

- Stir thoroughly before applying the primer. Use a spray gun or brush depending on working conditions.

#### ⚠ WARNING

- Ventilate when spraying paint. Most paint contains substances that are harmful if inhaled or swallowed. Read the paint label before opening the paint container.
- Avoid contact with skin. Wear an approved respirator, gloves, eye protection and appropriate clothing when painting.
- Paint is flammable. Store it in a safe place, and keep it away from sparks, flames or cigarettes.
- Cover as wide an area as possible, except for shallow grooves (2-3 coats).

NOTE:

- Do not dilute the primer with thinner.
- Warm the primer if the outside temperature is below 50°F (10°C).
- Apply the primer to the back of the bumper if the damage is a tear or hole.

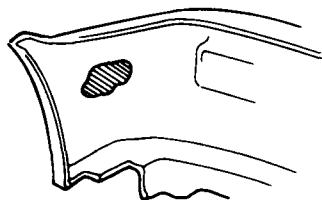

### 4. Drying bumper primer.

#### ⚠ WARNING

Body parts being dried with an industrial dryer can get hot enough to cause injury. Do not touch parts being dried.

- Dry the primer thoroughly with an infrared dryer or other dryer suitable for the purpose.

(cont'd)



# Polypropylene (PP) Resin Parts

## Refinishing Procedures (cont'd)

- If the damage or groove is shallow, heat the entire surface evenly. Apply heat locally if the bumper is gouged or torn open.

Drying time:

Dryer	10 minutes 140°F (60°C)
Natural	20 minutes 68°F (20°C)

NOTE:

- Use a dryer whenever possible.
- Do not allow temperature to exceed 158°F (70°C) or the bumper will deform

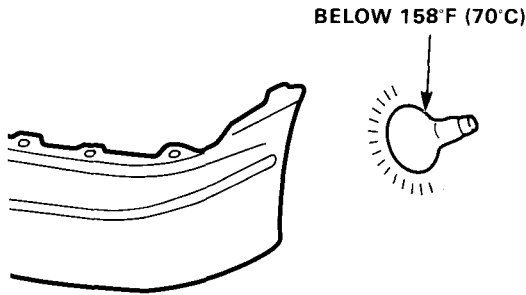

### 5. Apply filler (BOND QUICK MENDER.)

Mix the mender (A) into the hardener (B) in the ratio of 1 to 1, and stir until they are thoroughly mixed.

- 1. Apply the mixture over the damaged area with a putty knife using light pressure.
- 2. Even out the surface to match the contour of the bumper.
- 3. If there is a hole, cover it with a masking tape from the back, and apply the filler over the outside surface.

After the filler has been dried, remove the tape and apply filler to the side that was taped.

NOTE: Apply filler so it extends over more than the damaged area.

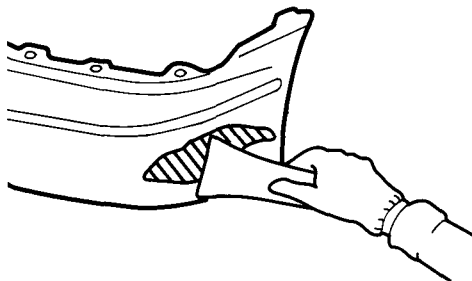

### 6. Drying filler

Drying time:

Almost hardened	5 minutes
Initial hardness	15 minutes
Practical hardness	60 minutes
Sanding 68°F (20°C)	After 3 hours
140°F (60°C)	After 30 minutes

### 7. Sanding filler

**⚠ WARNING** To prevent eye injury, wear goggles or safety glasses whenever sanding, cutting or grinding.

Wet sand first with #240 sandpaper then with #400 sandpaper.

NOTE: Sand the surface evenly, particularly at the area where the PP resin and mender meet.

### 8. Degreasing/Cleaning

- Blow off the sanded surface, then clean with wax and grease remover.

**⚠ WARNING**

- Do not use high air pressure; use only an approved, 210 kPa (2.1 kgf/cm<sup>2</sup>, 30 psi) air nozzle.
- Wear goggles or safety glasses to prevent eye injury.
- Remove all dust and dirt with a tack cloth.

## 9. Spraying dual-liquid bumper primer surfacer (gray)

NOTE: Use the urethane bumper primer.

### ⚠ WARNING

- **Ventilate when spraying paint.** Most paint contains substances that are harmful if inhaled or swallowed. Read the paint label before opening the paint container.
- **Avoid contact with skin.** Wear an approved respirator, gloves, eye protection and appropriate clothing when painting.
- **Paint is flammable.** Store it in a safe place, and keep it away from sparks, flames or cigarettes.

Spray the primer surfacer over a wider area than the filler and the exposed surfaces of bumper primer.

NOTE: Spray 2-3 coats to get 20-25 microns of thickness.

Mixing Ratio: (Reference)

Urethane bumper primer	10
Hardener	1
Thinner	30-60%

## 10. Drying and polishing

Force dry the primer surfacer with infrared lamps or other industrial dryer.

⚠ **WARNING** Body parts being dried with an industrial dryer can get hot enough to cause injury. Do not touch parts being dried.

Drying temperature:

Force drying	140°F (60°C) 20 minutes
Natural drying	68°F (20°C) 2 hours min

NOTE:

- Use a dryer whenever possible.
- Do not allow the temperature to exceed 158°F (70°C).
- 1. After force drying, wet sand the primer surface with #600 sandpaper.

NOTE: Use #600 or finer sandpaper as any paper coarser than this might scratch the surface.

### ⚠ WARNING

- **Do not use high air pressure; use only an approved, 210 kPa (2.1 kgf/cm<sup>2</sup>, 30 psi) air nozzle**
- **Wear goggles or safety glasses to prevent eye injury.**

-2. Air blow the surface to be repaired, then degrease with a wax and grease remover.

-3. Also clean and degrease where masking tape will be attached.

## 11. Intermediate coating

NOTE: Intermediate coating is recommended for bright colors.

- Use the top coat enamel.

### ⚠ WARNING

- **Ventilate when spraying paint.** Most paint contains substances that are harmful if inhaled or swallowed. Read the paint label before opening the paint container.
- **Avoid contact with skin.** Wear an approved respirator, gloves, eye protection and appropriate clothing when painting.
- **Paint is flammable.** Store it in a safe place, and keep it away from sparks, flames or cigarettes.
- Mix the additive into the solid enamel color, metallic enamel or pearl enamel color in the ratio of 1 to 5 (by weight).
- Mix the hardener into the mixture of pigment and additive described above in the ratio of 1 to 4 (by weight).

NOTE: Keep the correct ratio, especially of the additive. Excessive additive takes longer to dry.

- Adjust to the proper viscosity for spray by adding the thinner specified for the primer into the mixture of primer additive and hardener.

Viscosity: 68°F (20°C) 11-13 sec.

(cont'd)

# Polypropylene (PP) Resin Parts

## Refinishing Procedures (cont'd)

NOTE: It is not necessary to apply the clear coat.

- Spray 2-3 coats of the top coat enamel to get 15-20 microns of thickness. The primer surfacer (gray) should not show through the top coat.

NOTE:

- Apply the top coat enamel to the repaired surface.
- Apply the top coat enamel to the entire surface of the primer surfacer when replacement is necessary.

### 12. Degreasing and Cleaning

Air dry the entire surface, then clean with wax and grease remover (for USA usage-Dupont 38125 Enamel Reducer).

NOTE: For shading or spot painting, polish the area with a polishing compound. Also sand with a #1500 paper to make a better bonding surface for the paint.

### 13. Masking

- Remove all existing masking paper, then mask with new paper.
- Use a heat resistant type masking tape (SCOTCH TAPE) where tape is attached directly to the bumper.
- Use brown paper or masking roll paper to cover.

NOTE:

- Mask the area completely to prevent overspray.
- Protect resin parts with aluminum foil under the brown paper or masking paper to prevent damage due to heat during baking.

### 14. Top Coating

- Air dry and degrease the surface before spraying the paint. Also clean the surface with a tack cloth.

#### **▲ WARNING**

- **Ventilate when spraying paint. Most paint contains substances that are harmful if inhaled or swallowed. Read the paint label before opening the paint container.**
- **Avoid contact with skin. Wear an approved respirator, gloves, eye protection and appropriate clothing when painting.**
- **Paint is flammable. Store it in a safe place, and keep it away from sparks, flames or cigarettes.**
- Remove dust and dirt from the surface to be coated with compressed air, then use a tack cloth.
- Use a strainer when filling the cup with paint.
- Spray the paint evenly over the surface so the replacement part is completely covered.
- For application of the top coating refer to step 11 " Intermediate coating."

NOTE: Do not try to cover the surface with one heavy coat. Apply several thin coats.

- With solid color (2-coat type), metallic color and pearl color enamels, allow final coat to flash-off (5-20 minutes) before applying clear coat.
- Mix the additive into the clear in the ratio of 1 to 5. Adding the hardener and adjusting viscosity should be done the same way as described on the previous page.  
Viscosity: 68°F (20°C) 13-15 sec.

Mixing Ratio (weight)

Metallic enamel/Clear solid enamel	Additive	Hardener
5	: 1=4	: 1

## 15. Drying top coat

**▲ WARNING** Body parts being dried with an industrial dryer can get hot enough to cause injury. Do not touch parts being dried.

- Before force drying, let it air dry for 5-10 minutes.
- Force dry the sprayed surface under the infrared lamps for 60-90 minutes.
- Keep the drying temperature between 140°F (60°C) and 158°F (70°C).

NOTE: Take care not to let the heat deform the part during the drying process.

## 16. Polishing and Buffing

- Let the paint dry gradually, then polish the surface carefully using a polishing compound and sponge buff.
- To remove lint or dirt, wet sand the surface with #2000 or finer paper first, then polish with compound.

NOTE: Polish all roughness caused by sanding thoroughly. To do this, first polish with very fine compound, then with ultra fine compound.

- After polishing, remove the masking paper and tape and wash the entire vehicle thoroughly.

# ABS/PC, A/EPDM/S Resin Parts

## General

The door mirror, and license plate trim are made ABS resin.

They can be repaired if the damage or deformation is minor in nature. This section covers ABS repair. Repairing ABS is different from other resins such as PP and urethane.

### NOTE:

- The ABS resin is the copolymer resin consisting of the three monomers of acrylonitrile, butadiene, and styrene.
- Polycarbonate is a generic name for high polymers which have the carbonic ester structure in the structural unit. The most prominent feature of polycarbonate is its tensile strength which shows the same level of yielding point as metals in the normal temperature. It also has outstanding impact strength compared to other plastics.

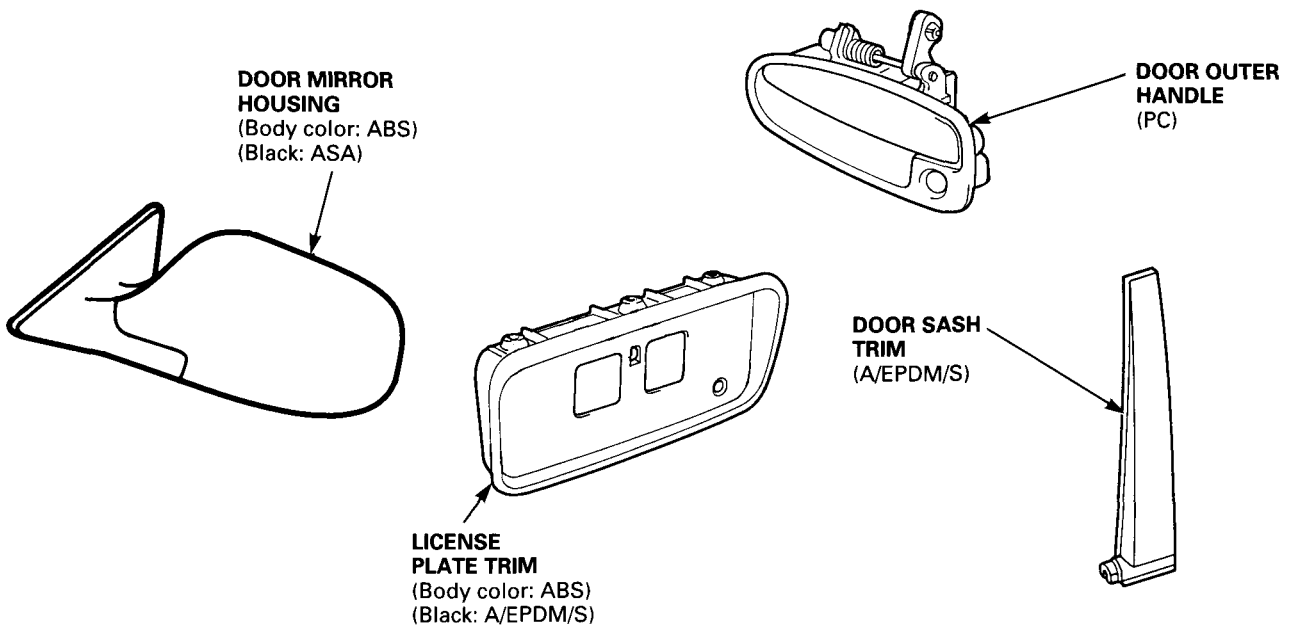

NOTE: The following repair procedures also apply to the PC resin and A/EPDM/S resin.

## Repair Materials

### Examples:

Adhesive and filler: Epoxy

- Kemit TE2301 bond quick mender

Filler:

- R-M Stop zinc (R-M)
- 3M 5900 Repair Material (Akzo)

NOTE: Follow the manufacturer's specification.

Top coat:

- Super ponacle II, Solo de Diamont, Diamont (R-M)
- Autocryl Auto base (Akzo)
- Super Centari (DuPont)

Primer/Primer surfacer:

Use when the resin material is exposed.

- R-M fast filler + R-M flex primer (R-M)
- Plasto flex primer 2 coat (Akzo)
- 1220RH-S filler primer (DuPont)

## Repair Procedures

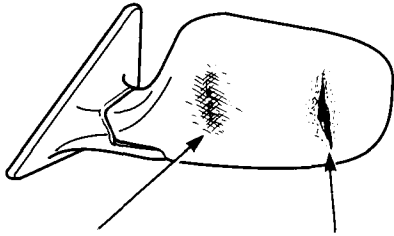

**B. SHALLOW SCRATCH:**  
1 mm approx.  
(0.04 in)

**A. DEEP SCRATCH:**  
2 mm approx  
(0.08 in)

### A. Deep scratches, when filling:

- (1) Sand the damage section. (#120-#240)
- (2) Apply the filler and dry.
- (3) Sand the filler (#240-#400)
- (4) Coat with the primer/primer surfacer and dry.
- (5) Sand the primer surfacer. (#600-#800)
- (6) Top coating.

### B. Shallow scratches:

- (1) Coat with the primer/primer surfacer.
- (2) Sand the primer surfacer. (#600-#800)
- (3) Top coating.

### C. Repaint:

- (1) Sand the primer surfacer. (#600-#800)
- (2) Top coating.

## Refinishing Procedures

### 1. Base material reconditioning (sanding)

- 1. Repaint and replacement part  
Lightly sand the part with #400, #600 or #800.
- 2. Slight scores or scratches  
Use a flexible sanding block and wet sand the damaged section with #400, #600.  
NOTE: Sand level to remove damage.
- 3. Deep scratches, when filling.  
Use a flexible sanding block and wet sand the damaged section with #240, #400.

### 2. Degreasing and cleaning

Clean the repaired area with wax and grease remover, then blow with air dry.

#### WARNING

- Do not use high air pressure; use only an approved, 210 kPa (2.1 kgf/cm<sup>2</sup>, 30 psi) air nozzle.
- Wear goggles or safety glasses to prevent eye injury.

NOTE: Wipe dust off surface with a tack cloth.

### 3. Filling, drying and sanding

Apply the filler in several thin coats.

NOTE: Mix and apply the filler according to the manufacturer's instructions.

- 1. Dry the filler with an infrared dryer for 5 or 6 minutes.  
Be sure to keep the dryer 40-50 cm (16-20 in) away from the surface.
- 2. Scratch the filled surface with your nail. If the surface is white when scratched, dry sand and wet sand with the #240-#400 paper. Be sure to sand level.

### 4. Cleaning with compressed air, and degreasing

Blow the entire area to be coated with compressed air, then clean with wax and grease remover.

#### WARNING

- Do not use high air pressure; use only an approved, 210 kPa (2.1 kgf/cm<sup>2</sup>, 30 psi) air nozzle.
- Wear goggles or safety glasses to prevent eye injury.

NOTE: Clean the whole surface to help the masking tape adhere securely.

(cont'd)

# ABS/PC, A/EPDM/S Resin Parts

## Refinishing Procedures (cont'd)

### 5. Masking

Use the masking tape and paper to mask the area that should not be sprayed.

### 6. Coat with primer/primer surfacer, drying and sanding.

- Spray the primer surfacer over the filled area.

#### ⚠ WARNING

- Ventilate when spraying paint. Most paint contains substances that are harmful if inhaled or swallowed. Read the paint label before opening the paint container.
  - Avoid contact with skin. Wear an approved respirator, gloves, eye protection and appropriate clothing when painting.
  - Paint is flammable. Store it in a safe place, and keep it away from sparks, flames or cigarettes.
  - Do not use high air pressure; use only an approved, 210 kPa (2.1 kgf/cm<sup>2</sup>, 30 psi) air nozzle.
  - Wear goggles or safety glasses to prevent eye injury.
- The coating thickness should be 20-25 microns.

NOTE: Follow the primer/primer surfacer manufacturer's instructions.

#### •1. Drying

- Let the primer surfacer dry naturally for 5 to 10 minutes, then dry with a infrared dryer.

#### ⚠ WARNING

**Body parts being dried with an industrial dryer can get hot enough to cause injury. Do not touch parts being dried.**

- Be sure to keep the dryer 40-50 cm (16-20 in) away from the paint film.

#### -2. Sanding

Lightly dry sand the whole area to be painted with #600, #800 sandpaper.

### 7. Blow off with compressed air, then clean with wax and grease remover.

#### ⚠ WARNING

- Do not use high air pressure; use only an approved, 210 kPa (2.1 kgf/cm<sup>2</sup>, 30 psi) air nozzle.
- Wear goggles or safety glasses to prevent eye injury.

NOTE: Clean the whole surface to help the masking tape adhere securely.

### 8. Top coating

- Remove dust with a tack cloth before spraying.
- Spray the top coating. Spray until the primer surfacer is covered.
- The coating thickness should be 30-35 microns.

#### ⚠ WARNING

- Ventilate when spraying paint. Most paint contains substances that are harmful if inhaled or swallowed. Read the paint label before opening the paint container.
- Avoid contact with skin. Wear an approved respirator, gloves, eye protection and appropriate clothing when painting.
- Paint is flammable. Store it in a safe place, and keep it away from sparks, flames or cigarettes.
- Do not use high air pressure; use only an approved, 210 kPa (2.1 kgf/cm<sup>2</sup>, 30 psi) air nozzle.
- Wear goggles or safety glasses to prevent eye injury.

NOTE: For the recommended top coat paint, refer to "Example of repair materials".

Solid color: Color enamel + color clear coat

Metallic: Metallic enamel + clear coat

Pearl: Pearl enamel + clear coat

### 9. Drying

After top coating for about 10 minutes, then dry with an infrared dryer.

NOTE: Follow the paint manufacturer's specification to dry properly.



# Glossary

All paint	Painting of complete surface.
Air blow	Using compressed air to blow away dust and debris.
Block paint	Painting a section only, such as a door.
Clear paint (clear coat)	Clear paint without dye (pigment).
Double coat	Application of two paint coats.
Dry coat	Paint which left the spray gun and dried partially before it reached the surface, thereby making the painted surface rough. Dry coating is caused by too little paint being fed, too high an air pressure, too much distance between the painted surface and the gun, or moving the gun too fast.
Dry film	Paint which has dried completely.
Dust coat	Paint is applied thinner than a dry coat. Painted surface becomes rough.
ED painting	Electrostatic discharge painting.
Enamel	Finishing paint pigmented with dye.
Featheredging	Smoothing off the edges of painted surfaces.
Flash off	Evaporation of the paint solvent. (Flash off time is the period between paint coat applications.)
Ford cup	A type of viscosity meter .
Gun stroke	Movement of the paint gun.
Hardener	Hardening agent of two-liquid type paint or fillers. Polycyanates and oxides are used for hardeners.
Heat-hardening acrylic resin paint	Composed of acrylic resin and meramine resin, and hardened (forms a paint film) by baking.

(cont'd)

# Glossary

(cont'd)

Lacquer	A type of paint that uses cellulose nitrate or other chemicals, and which dries by evaporation of its solvent agent.
Meramine resin	Used as component for aminoalkyd resin paint and heat-hardening acrylic resin paint.
Metallic-base paint	Paint with aluminum powder for metallic tone.
Mist coat	Painting for fade-in sections. A small amount of paint may be dissolved with slow-evaporating thinner, or thinner alone may be applied with low pressure. 150-200 kPa (1.5-2.0 kgf/cm <sup>2</sup> , 21.3-28.4 psi)
Mixing scale	Color mixing device.
Overlap	Blending of spray patterns.
Overspray	Spraying other than the area that needs painting.
Paddle	A tool to mix paint.
Paint dust	Dust of paint formed by spraying.
Paper dispenser	A paper posting device (masker) that combines tape and paper.
Scrapes	Traces of scratches.
Scuffing	Particles on the painted surface are lightly polished with fine emery paper (#600 or over).
Set (setting)	Evaporation time of solvent in the paint, before drying the layer forcefully or by baking. (May be considered the same as flash-off time.)
Single coat-	Application of paint in single layer.
Spot paint	Painting of small section, such as for touch-up.
Undercoat	Undercoat paint (such as primer and surfacer). <b>May be applied to lower section of car for noise prevention and rustproofing.</b>

Wet coat	Paint is applied with an excess of solvent, thereby producing a painted surface that's smooth, glossy, and has a wet look.
Wet film	Paint which has not dried completely.
Wet on wet	Application of the next coat of paint before the preceding layer has dried completely.
Wool bonnet	Wool grinder for compound polishing.

# General Safety Precautions

## **Before beginning work:**

Disconnect the battery to reduce the possibility of fire caused by electrical shorts.

Check for fuel leaks and repair as necessary.

Remove the fuel tank and/or fuel lines if welding equipment is to be used near the fuel system.

Before welding, sanding or cutting, protect carpets and seats with fire-proof covers.

Follow standard safety practices when using toxic or flammable liquids.

Use standard safety equipment when spraying paint, welding, cutting, sanding or grinding. Standard safety equipment includes:

Respirator and filter masks—Designed to filter out toxic fumes, mist, dust or other airborne particles. Use a respirator or filter mask designed to protect you from the hazards of the particular job; some respirators, for example, are designed to filter out only dust and airborne particles, not toxic fumes.

Safety goggles or glasses—Designed to protect your eyes from projectiles, dust particles or splashing liquid.

Gloves — Rubber gloves protect against corrosive chemicals. Welding gloves protect against burns and abrasions caused by welding, sanding or grinding.

Safety shoes—Non-slip soles protect against slipping. Metal toe inserts protect against falling objects.

Ear plugs — Protect eardrums from harmful noise levels.

## **During work:**

Do not smoke while working near the fuel system.

Deposit gas or solvent-soaked shop towels in an approved container.

Always attach a safety cable when using a hydraulic ram or a frame straightening table: do not stand in direct line with the chains used on such equipment.

# Service Precautions

## Supplemental Restraint System (SRS)

The Civic SRS includes a driver's airbag, located in the steering wheel hub, and, on most models, a passenger's airbag located in the dashboard above the glove box. The SRS unit is not part of the airbag assembly and has built-in sensors.

NOTE: The following precautions should be observed when performing sheet metal work, paint work and repair work around the locations of the SRS components.

- ① The SRS unit (including safing sensor and impact sensor) is located under the dashboard. Avoid strong impact with a hammer or other tools when repairing the front side frame and the lower part of the dashboard. Do not apply heat to these areas with a torch, etc.
- ② All SRS electrical wiring harnesses are located under the lower part of the dashboard below the dashboard panel. (All SRS electrical wiring harnesses are covered with yellow insulation.) Care should be taken not to damage the harness when repairing this area.
- ③ Do not apply heat of more than 212°F (100°C) when drying painted surfaces anywhere around the locations of SRS components.
- ④ If strong impact or high temperature needs to be applied to the areas around the locations of SRS components, remove the components before performing repair work.
- ⑤ If any of the SRS related components are damaged or deformed, be sure to replace them.

NOTE: Refer to the Service Manual (Supplemental Restraint System) for removal and replacement of SRS related components.

